

harman/kardon

AVR347

7 X 55W 7.1 CHANNEL A/V RECEIVER

SERVICE MANUAL



CONTENTS

ESD WARNING.....	2	DISASSEMBLY.....	43
LEAKAGE TESTING.....	3	UNIT EXPLODED VIEW.....	48
BASIC SPECIFICATIONS.....	4	EXPLODED VIEW PARTS LIST.....	49
PACKAGING.....	5	AMP BIAS ADJUSTMENT.....	50
FRONT PANEL CONTROLS.....	6	BLOCK DIAGRAM.....	51
REAR PANEL CONNECTIONS.....	8	ELECTRICAL PARTS LIST.....	52
REMOTE CONTROL FUNCTIONS.....	11	PCB DRAWINGS.....	98
CONNECTIONS.....	14	SEMICONDUCTOR PINOUTS.....	107
OPERATION.....	33	SCHEMATICS.....	209
TROUBLESHOOTING GUIDE.....	41	WIRING DIAGRAM.....	219
PROCESSOR RESET.....	42		

harman/kardon, Inc.
250 Crossways Park Dr.
Woodbury, New York 11797

Rev 1 2/2009

ELECTROSTATICALLY SENSITIVE (ES) DEVICES

Some semiconductor (solid state) devices can be damaged easily by static electricity. Such components commonly are called Electrostatically Sensitive (ES) Devices. Examples of typical ES devices are integrated circuits and some field effect transistors and semiconductor "chip" components.

The following techniques should be used to help reduce the incidence of component damage caused by static electricity.



1. Immediately before handling any semiconductor component or semiconductor-equipped assembly, drain off any electrostatic charge on your body by touching a known earth ground. Alternatively, obtain and wear a commercially available discharging wrist strap device, which should be removed for potential shock reasons prior to applying power to the unit under test.
2. After removing an electrical assembly equipped with ES devices, place the assembly on a conductive surface such as aluminum foil, to prevent electrostatic charge build-up or exposure of the assembly.
3. Use only a grounded-tip soldering iron to solder or unsolder ES devices.
4. Use only an anti-static solder removal device. Some solder removal devices not classified as "anti-static" can generate electrical charges sufficient to damage ES devices.
5. Do not use freon-propelled chemicals. These can generate electrical change sufficient to damage ES devices.
6. Do not remove a replacement ES device from its protective package until immediately before you are ready to install it. (Most replacement ES devices are packaged with leads electrically shorted together by conductive foam, aluminum foil or comparable conductive material.)
7. Immediately before removing the protective material from the leads of a replacement ES device, touch the protective material to the chassis or circuit assembly into which the device will be installed.

CAUTION : Be sure no power is applied to the chassis or circuit, and observe all other safety precautions.

8. Minimize bodily motions when handling unpackaged replacement ES devices. (Otherwise harmless motion such as the brushing together of your clothes fabric or the lifting of your foot from a carpeted floor can generate static electricity sufficient to damage an ES devices.

PRODUCT SAFETY NOTICE

Each precaution in this manual should be followed during servicing.

Components identified with the IEC symbol  in the parts list are special significance to safety. When replacing a component identified with , use only the replacement parts designated, or parts with the same ratings or resistance, wattage, or voltage that are designated in the parts list in this manual. Leakage-current or resistance measurements must be made to determine that exposed parts are acceptably insulated from the supply circuit before returning the product to the customer.

SAFETY PRECAUTIONS

The following check should be performed for the continued protection of the customer and service technician.

LEAKAGE CURRENT CHECK

Measure leakage current to a known earth ground (water pipe, conduit, etc.) by connecting a leakage current tester between the earth ground and all exposed metal parts of the appliance (input/output terminals, screwheads, metal overlays, control shaft, etc.). Plug the AC line cord of the appliance directly into a 120V AC 60Hz outlet and turn the AC power switch on. Any current measured must not exceed 0.5mA.

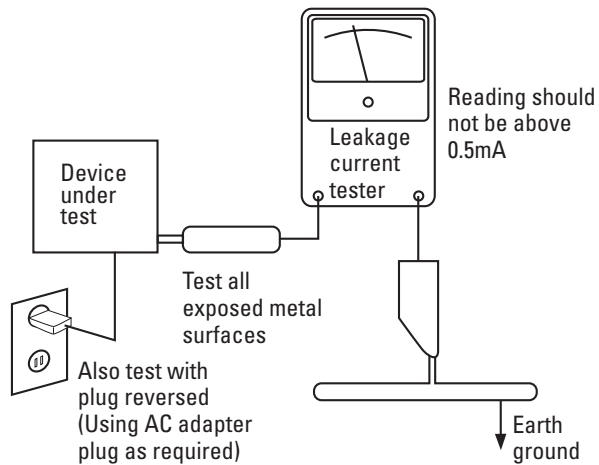

AC Leakage Test

ANY MEASUREMENTS NOT WITHIN THE LIMITS OUTLINED ABOVE ARE INDICATIVE OF A POTENTIAL SHOCK HAZARD AND MUST BE CORRECTED BEFORE RETURNING THE APPLIANCE TO THE CUSTOMER.

AVR 347 TECHNICAL SPECIFICATIONS

Audio Section

Stereo Mode
 Continuous Average Power (FTC)
 70 Watts per channel, 20Hz–20kHz,
 @ <0.07% THD, both channels driven into 8 ohms

Seven-Channel Surround Modes

Power per Individual Channel

Front L&R channels:
 55 Watts per channel
 @ <0.07% THD, 20Hz–20kHz into 8 ohms

Center channel:
 55 Watts @ <0.07% THD, 20Hz–20kHz into 8 ohms

Surround (L & R Side, L & R Back) channels:
 55 Watts per channel
 @ <0.07% THD, 20Hz–20kHz into 8 ohms

Input Sensitivity/Impedance
 Linear (High-Level) 200mV/47k ohms

Signal-to-Noise Ratio (IHF-A) 100dB

Surround System Adjacent Channel Separation

Pro Logic I/II 40dB

Dolby Digital (AC-3) 55dB

DTS 55dB

Frequency Response
 @ 1W (+0dB, -3dB) 10Hz – 130kHz

High Instantaneous
 Current Capability (HCC) ±35 Amps

Transient Intermodulation
 Distortion (TIM) Unmeasurable

Slew Rate 40V/μsec

FM Tuner Section

Frequency Range 87.5–108.0MHz
 Usable Sensitivity IHF 1.3μV/13.2dBf
 Signal-to-Noise Ratio Mono/Stereo 70/68dB
 Distortion Mono/Stereo 0.2/0.3%
 Stereo Separation 40dB @ 1kHz
 Selectivity ±400kHz, 70dB
 Image Rejection 80dB
 IF Rejection 90dB

AM Tuner Section

Frequency Range 520–1720kHz
 Signal-to-Noise Ratio 45dB
 Usable Sensitivity Loop 500μV
 Distortion 1kHz, 50% Mod 0.8%
 Selectivity ±10kHz, 30dB

Video Section

Television Format NTSC
 Input Level/Impedance 1Vp-p/75 ohms
 Output Level/Impedance 1Vp-p/75 ohms
 Video Frequency Response (Composite and S-Video) 10Hz–8MHz (-3dB)
 Video Frequency Response (Component Video) 10Hz–100MHz (-3dB)
 HDMI™ Audio and video processing

General

Power Requirement AC 120V/60Hz
 Power Consumption 65W idle, 540W maximum
 (7 channels driven)

Dimensions	(Product)	(Shipping)
Width	17-5/16 inches (440mm)	22 inches (559mm)
Height	6-5/8 inches (165mm)	10-1/2 inches (267mm)
Depth	15 inches (382mm)	18-1/4 inches (464mm)

Weight	(Product)	(Shipping)
	30.6 lb (13.9kg)	35.6 lb (16.2kg)

Depth measurement includes knobs, buttons and terminal connections.

Height measurement includes feet and chassis.

All features and specifications are subject to change without notice.

Harman Kardon and Logic 7 are trademarks of Harman International Industries, Incorporated, registered in the United States and/or other countries. EzSet/EQ,  Bridge, and Designed to Entertain are trademarks of Harman International Industries, Incorporated.

A-BUS is a registered trademark of LeisureTech Electronics Pty Ltd.

Apple, iTunes and iPod are trademarks of Apple Inc., registered in the U.S. and other countries. Shuffle is a trademark of Apple Inc.

Audiovox is a registered trademark of Audiovox Corporation.

Blu-ray Disc is a trademark of the Blu-ray Disc Association.

CEA is a registered trademark of the Consumer Electronics Association.

Cirrus Logic is a registered trademark of Cirrus Logic, Inc.

Dolby, Pro Logic and the double-D symbol are trademarks of Dolby Laboratories.

Manufactured under license from Dolby Laboratories.

"DTS" and "DTS ES|Neo:6" are registered trademarks of DTS, Inc. "96/24" is a trademark of DTS, Inc.

Faroudja and DCDi by Faroudja are registered trademarks of Genesis Microchip Inc.

HD-DVD is a trademark of the DVD Format/Logo Licensing Corporation (DVD FLLC).

HDMI is a trademark of HDMI Licensing LLC.

Microsoft and Xbox are registered trademarks of Microsoft Corporation in the United States and other countries.

SACD is a trademark of Sony Corporation.

The Simplay HD logo and the Simplay, Simplay HD and Simplay Labs trademarks are owned by Silicon Image, Inc. and are used under license from Silicon Image, Inc. and/or Simplay Labs, LLC.

TiVo is a registered trademark of TiVo Inc.

XM and XM Ready are registered trademarks of XM Satellite Radio.



The AVR 347 is Simplay HD™-verified for compatibility via the HDMI connection with other Simplay HD-verified products.

Please register your AVR 347 on our Web site at www.harmankardon.com.

NOTE: You'll need the product's serial number. At the same time, you can choose to be notified about our new products and/or special promotions.

1. Instruction manual ass'y - Accessories

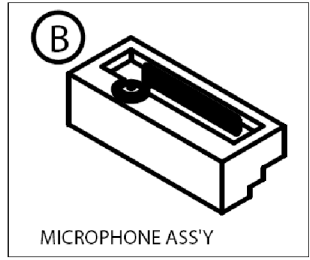
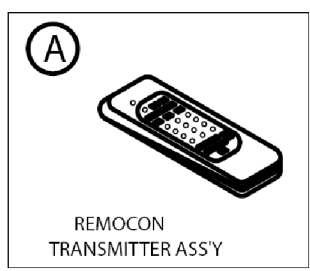
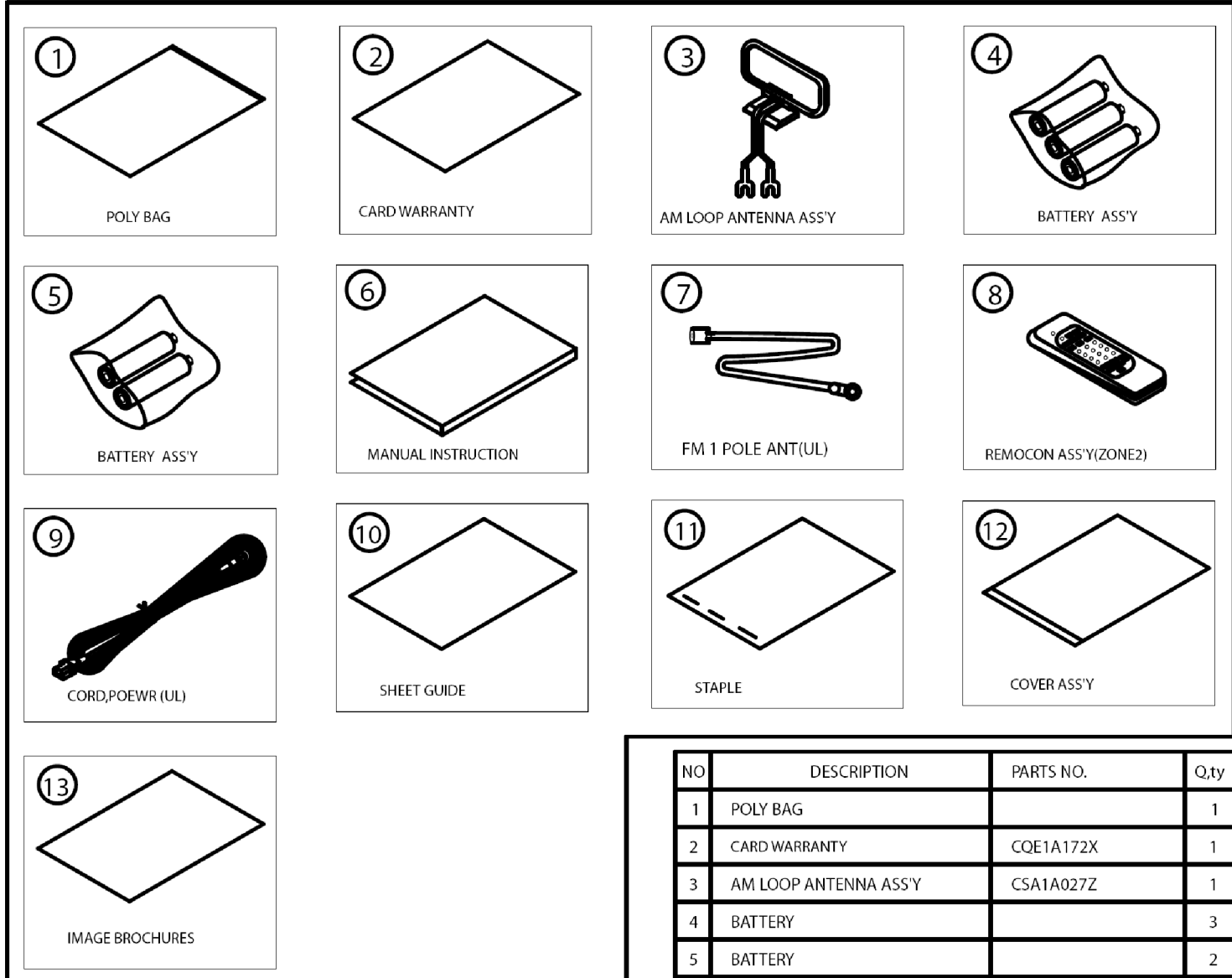

NO	DESCRIPTION	PARTS NO.	Q,ty
1	POLY BAG		1
2	CARD WARRANTY	CQE1A172X	1
3	AM LOOP ANTENNA ASS'Y	CSA1A027Z	1
4	BATTERY		3
5	BATTERY		2
6	INSTRUCTION MANUAL	COX1A1185Z	1
7	FM 1 POL ANT(UL)	CSA1A019Z	1
8	REMOCON ASS'Y(ZONE2)	HARTZONE23	1
9	CORD,POWER(UL)	CJA2A070Z	1
10	SHEET GUIDE		1
11	STAPLE		3
12	COVER ASS'Y	CGRAVR130ZA	1
	1 COVER A	CGR1A331M7H43	1
	2 COVER B	CGR1A332M7H43	1
	3 SHEET,FRONT COVER	CQE1A219Z	1
	4 PAD, COVER	CPS1A676	1
	5 BAG ,POLY		1
13	IMAGE BROCHURES		1
A	REMOCON ASS'Y	CARTAVR347	1
B	MICROPHONE ASS'Y	CJXAVR340MICRO	1

2. Package Drawing

AVR347

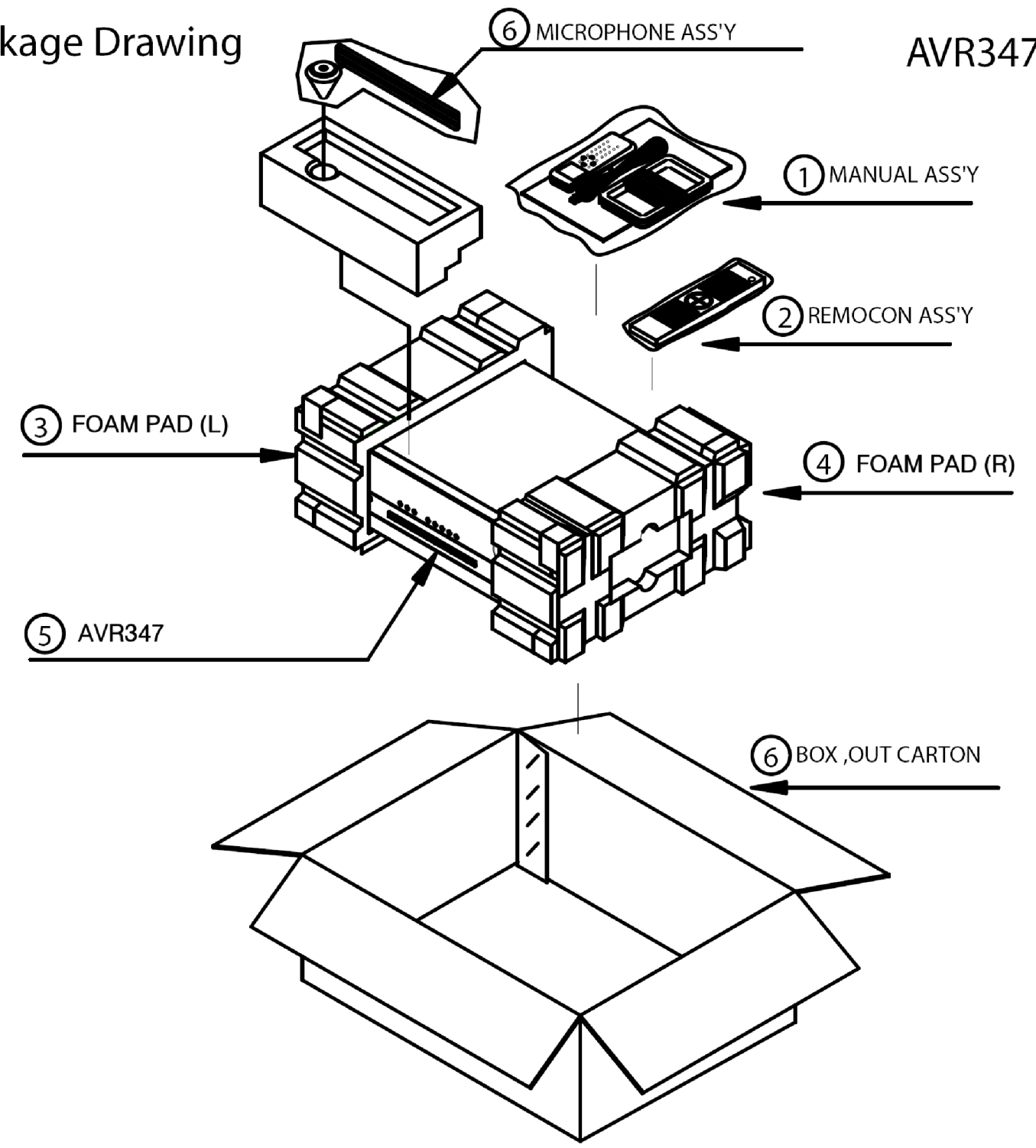

NO	DESCRIPTION	PARTS NO.	Q,ty
1	MANUAL ASS'Y		1
2	REMOCON ASS'Y	CARTAVR347	1
3	FOAM PAD (L)	CPS6A564	1
4	FOAM PAD (R)	CPS6A565	1
5	AVR347	AVR347	1
6	BOX,OUT CARTON	CPG1A822W	1
7	MICROPHONE ASS'Y	CJXAVR340MICRO	1

FRONT-PANEL CONTROLS

Main Power Switch: This mechanical switch turns the power supply on or off. It is usually left pressed in (On position), and cannot be turned on using the remote control.

Standby/On Switch: This electrical switch turns the receiver on for playback, or leaves it in Standby mode for quick turn-on using this switch or the remote control.

Power Indicator: This LED has three possible modes. When main power is turned off, the LED is dark and the receiver won't respond to any button presses. When main power is turned on, but before the Standby/On Switch is used, the LED turns amber to indicate that the receiver is in Standby mode and ready to be turned on. When the receiver is turned on, the LED turns blue.

Source Select: Press this button to select a source device, which is a component where a playback signal originates, e.g., DVD, CD, cable TV, satellite or HDTV tuner.

Source Indicators: The name of the current source input lights up. The indicated input changes each time the Source Select button is pressed.

Volume Knob: Turn this knob to raise or lower the volume, which will be shown in decibels (dB) in the Message Display.

Message Display: Various messages appear in this two-line display in response to commands and changes in the incoming signal. When the on-screen display menu system (OSD) is in use, the message OSD ON will appear to remind you to check the video display.

Tuner Band: Press this button to select the tuner as the source, to switch between the AM and FM bands, or to select XM satellite radio.

Tuning: Press either side of this button to tune a radio station or XM channel.

Tuning Mode: This button toggles between manual (one frequency step at a time) and automatic (seeks frequencies with acceptable signal strength) tuning mode. It also toggles between stereo and mono modes when an FM station is tuned.

When XM Radio is in use, pressing this button repeatedly displays the channel name, category, artist and track title in the lower line of the Message Display. For traffic-and-weather channels, this button displays the city, channel name, local weather and local temperature.

Preset Stations: Press this button to select a preset radio station.

Headphone Jack/EzSet/EQ Microphone Input: Plug a 1/4" headphone plug into this jack for private listening.

This jack is also used to connect the supplied microphone before beginning the EzSet/EQ procedure described in the Initial Setup section. To begin EzSet/EQ, plug the supplied microphone into this jack, place the microphone at the listening position, and follow the directions given in the SPEAKER SETUP on-screen menu.

Surround Mode: Press this button to select a surround sound (e.g., multichannel) mode group. Choose from the Dolby modes, DTS modes, Logic 7 modes, DSP modes or Stereo modes.

Surround Select: After you have selected the desired surround mode group, press this button to select a specific mode.

Surround Mode Indicators: One or more of these icons may light up as you select different surround modes. The Message Display also indicates the surround mode.

Analog Audio, Video and Digital Audio Inputs: Connect a source component that will only be used temporarily, such as a camera or game console, to these jacks. Use only one type of audio and one type of video connection.

Speaker/Channel Input Indicators: The box icons indicate which speaker positions you have configured, and the size (frequency range) of each speaker. When a digital audio input is used, letters will light inside the boxes to indicate which channels are present in the incoming signal.

Navigation: These buttons are used together with the following five buttons to make selections.

Tone Mode: Press this button to access the tone controls (bass and treble). Use the ◀/▶ Navigation Buttons to make your selections.

Speaker: Press this button to configure speaker sizes; that is, the low-frequency-range capability of each speaker.

Channel Level Adjust: Press this button to set the output level for each channel so that all speakers sound equally loud at the listening position.

Digital Input Select: Press this button to select the specific digital audio input (or analog audio input) you used for the current source.

Delay: Press this button to set delay times that compensate for placing the speakers at different distances from the listening position.

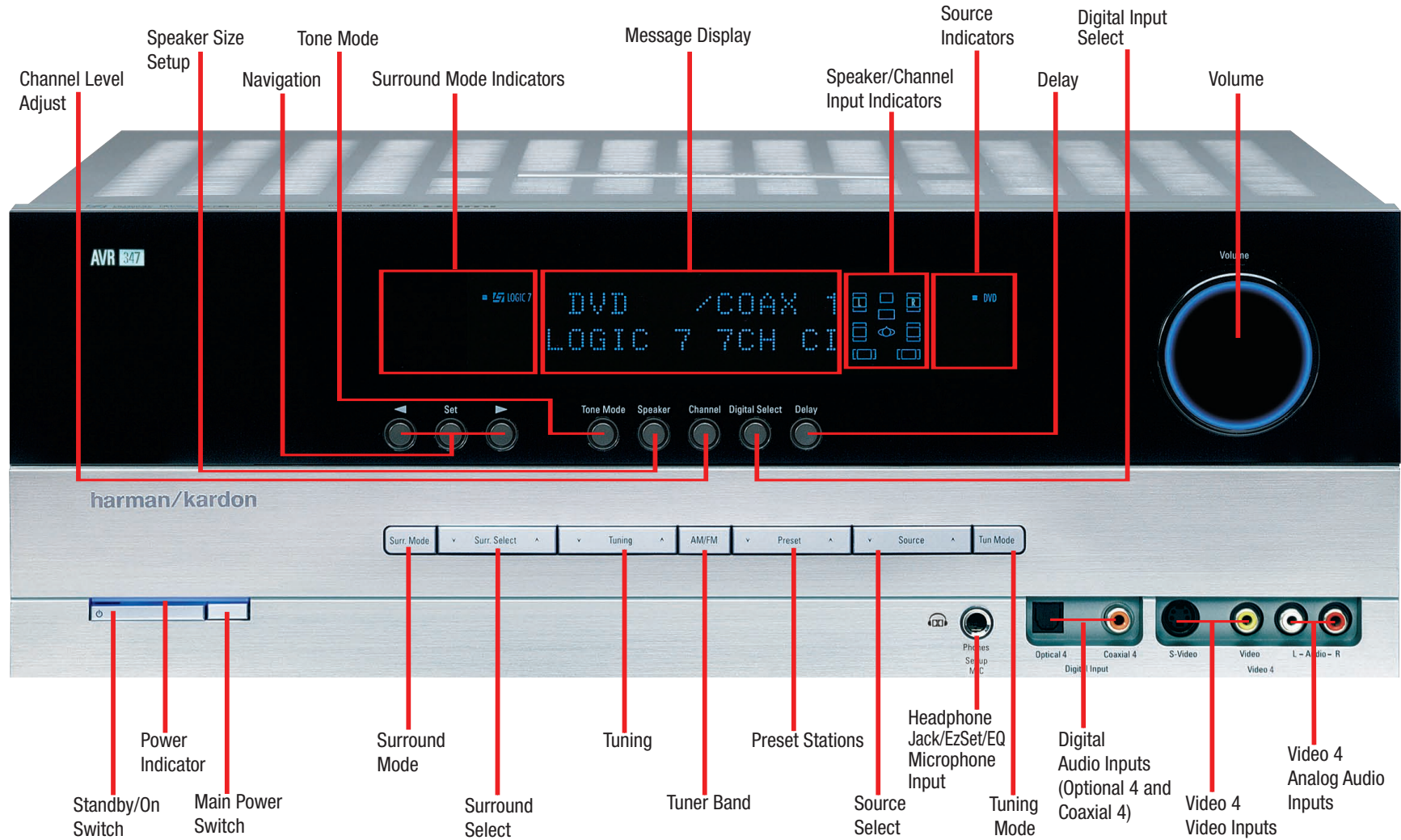

NOTE: To make it easier to follow the instructions throughout the manual that refer to this illustration, a copy of this page may be downloaded from the Product Support section at www.harmankardon.com.

REAR-PANEL CONNECTIONS

AM and FM Antenna Terminals: Connect the included AM and FM antennas to their respective terminals for radio reception.

XM Antenna Jack: Plug in an XM antenna module here. The XM antenna module is purchased separately, and should specify that it is for home use with an XM Ready® product. You will need to subscribe to the XM service, which is available separately, and activate the service for your antenna module. (XM service is not available in Alaska and Hawaii.)

Front, Center and Surround Speaker Outputs: Use two-conductor speaker wire to connect each set of terminals to the correct speaker. Remember to observe the correct polarity (positive and negative connections). Always connect the positive lead to the colored terminal on the receiver and the red terminal on the speaker. Connect the negative lead to the black terminal on both the receiver and the speaker. See the Connections section for more information on connecting your speakers.

Surround Back/Multiroom Speaker Outputs: These speaker outputs may be used either for the surround back channels in a 7.1-channel home theater, or they may be reassigned to a remote room for use with a multiroom system. When these outputs are reassigned for multiroom operation, only a 5.1-channel configuration will be available in the main listening room. Use the on-screen menu system to configure these channels as desired.

As with the other speaker outputs, remember to observe proper polarity by connecting the positive and negative output terminals to the corresponding terminals on each speaker.

Subwoofer Output: If you have a powered subwoofer with a line-level input, connect it to this jack.

Preamp Outputs: Connect these jacks to an external amplifier if more power is desired.

Surround Back/Multiroom Preamp Outputs: These outputs may be used with an external amplifier either to power the surround back channels, or to power the speakers in the remote zone of a multi-channel system. Use the on-screen menu system to configure these channels as desired.

Remote Infrared (IR) Input and Output: When the remote IR receiver on the front panel is blocked, such as when the AVR is placed inside a cabinet, connect an optional IR receiver to the Remote IR Input jack for use with the remote control. The Remote IR Output may be connected to the Remote IR Input of a compatible source device (or other product) to enable remote control through the AVR. This is particularly useful in multiroom applications, when you wish to control the source device from the remote room (when used with the Multiroom IR Input). When several source devices are used, connect them in “daisy chain” fashion.

Multiroom Infrared (IR) Input: Connect a remote IR receiver located in the remote zone of a multiroom system to this jack to control the AVR and any source devices connected to the Remote IR Output from the remote zone.

Remote IR Carrier Output: This output is similar in function to the Remote IR Output, with the difference that this jack outputs the full infrared signal as received by the AVR’s IR sensor or the Remote IR Input, while the Remote IR Output jack outputs a “stripped” signal that has no carrier frequency. The full signal may be required by some components with IR inputs. It may also be required when you connect external IR emitters or other devices to the AVR to pass IR signals to other components.

Multiroom Audio Outputs: Connect these jacks to an external amplifier to power the speakers in the remote zone of a multiroom system. When these jacks are used, it is possible to have a full 7.1-channel system in the main listening room at the same time the multiroom system is in use.

A-BUS Port: Use a Category 5/5e cable to connect this port to optional A-BUS equipment for multiroom operation. When the A-BUS system is used, it is possible to have a full 7.1-channel system in the main listening room at the same time the multiroom system is in use.

Video 1, Video 2, Video 3 and DVD Audio/Video Inputs: These jacks may be used to connect your video-capable source components (e.g., VCR, DVD player, cable TV box) to the receiver. Remember to use only one type of video connection for each source. See the Connections section for more information on audio and video connection options for each source component.

Video 1 Audio/Video Outputs: These jacks may be used to connect your VCR or another recorder.

Composite and S-Video Monitor Outputs: If any of your sources use composite or S-video connections, you may need to connect one or both of these monitor outputs to the corresponding inputs on your television or video display in order to view the sources and to view the on-screen displays. If your video display is equipped with component video or HDMI inputs, you may take advantage of the AVR 347’s transcoding capability, which transcodes composite and S-video signals to component video and HDMI, allowing for only a single video connection from the AVR to the video display.

HDMI Inputs and Output: HDMI (High-Definition Multimedia Interface) is a newer type of connection for transmitting digital audio and video signals between devices. With the AVR 347’s powerful processor, you may connect up to two HDMI-equipped source devices to the HDMI inputs using a single-cable connection, while benefiting from superior digital audio and video performance. However, if your video display is not HDMI-compatible, you will need to connect the device to one of the other source inputs, selecting a coaxial or optical digital audio input and analog video input. See the Connections and Installation sections for more information.

If your video display has an HDMI input, but some of your sources have only analog video outputs, you may still rely on just the HDMI video connection to your display; the AVR 347 will automatically transcode analog video signals up to 720p to the HDMI format. High-resolution analog 1080i or higher signals are not available at the HDMI Output.

REAR-PANEL CONNECTIONS

The AVR 347 is Simplay HD-verified for compatibility via the HDMI connection with other Simplay HD-verified products.

CD and Tape Audio Inputs: These jacks may be used to connect audio-only source components (e.g., CD player, tape deck). Do not connect a turntable to these jacks without a phono preamp.

Tape Outputs: These jacks may be used to connect a CDR or another audio-only recorder.

Coaxial and Optical Digital Audio Inputs: If a source has a compatible digital audio output, connect it to one of these jacks for improved audio performance. Use only one type of digital audio connection for each source.

Coaxial and Optical Digital Audio Outputs: If a source is also an audio recorder, you may connect a compatible digital audio output to the recorder's input for improved recording quality.

The Bridge/DMP Input: Connect the optional Harman Kardon  to this input for use with your iPod (not included). Make sure the receiver is turned off (in Standby mode) when connecting The Bridge.

6-/8-Channel Inputs: Connect the multichannel analog audio outputs of a DVD-Audio, SACD™, Blu-ray Disc™ or HD-DVD™ player (or any other external decoder) to these jacks to enjoy these proprietary formats.

NOTE: When an HD-DVD or Blu-ray Disc player has an onboard digital decoder, it is not necessary to connect it to the 6-/8-Channel Analog Audio Inputs. Only a digital audio connection (HDMI, coaxial or optical) is needed.

Component Video Inputs: If both a video source (e.g., DVD player or HDTV tuner) and your television or video display have analog component video (Y/Pb/Pr) capability and if you are not using HDMI connections for the device, then you may connect the component video outputs of the source to one of the two component video inputs. Do not make any other video connections to that source.

Component Video Monitor Outputs: If you are using one of the Component Video Inputs and your television or video display is component-video-capable and if you are not connecting the HDMI output to our display, you may connect these jacks to the corresponding inputs on your video display.

NOTES:

- Due to copy-protection restrictions, there is no output at the Component Video Monitor Outputs for copy-protected sources.
- High-resolution 1080i and 1080p video signals are not available at the HDMI Output, and are downconverted to 720p for the Component Video Outputs. If your source output is analog high-resolution video, either use the Component Video Outputs, lower the output resolution of your source device, or connect your source's component video outputs directly to your video display.

- Due to the design of some video displays, analog 480p or 720p component video source signals may produce artifacts when used with the AVR's analog video outputs (composite, S-video or component video). If this occurs, try changing the Video Mode setting in the INPUT SETUP menu, or connecting the source device's video output directly to your video display. However, for best results, we recommend you consider upgrading to an HDMI-capable video display.

RS-232 Serial Port: This specialized connector may be used with your personal computer in case Harman Kardon offers a software upgrade for the receiver at some time in the future.

RS-232 Mode: Leave this switch popped out in the Operate position unless the AVR 347 is being upgraded.

RS-232 Reset: This switch is only used during a software upgrade. A standard processor reset is performed by pressing and holding the front-panel Tone button.

Switched AC Accessory Outlet: You may plug the AC power cord of one source device into this outlet, and it will turn on whenever you turn on the receiver. Do not use a source that consumes more than 50 watts of power.

AC Power Cord Input: After you have made all other connections, plug the AC power cord into an unswitched outlet. Plug the female end of the cord into this receptacle, which conveniently allows you to install all wiring ahead of time.

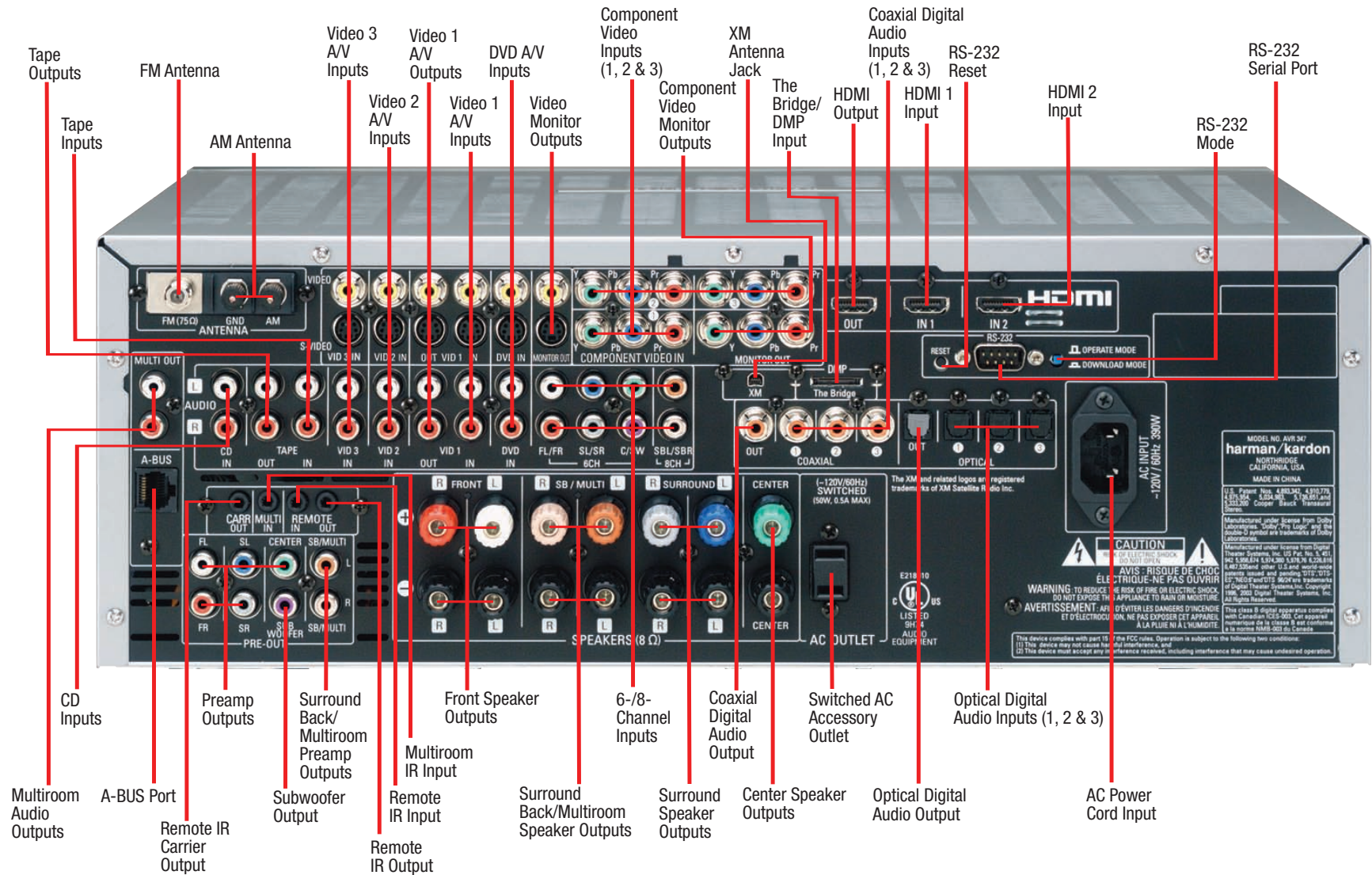

NOTE: To make it easier to follow the instructions throughout the manual that refer to this illustration, a copy of this page may be downloaded from the Product Support section at www.harmankardon.com.

MAIN REMOTE CONTROL FUNCTIONS

The AVR 347 remote is capable of controlling 11 devices, including the AVR itself and an iPod docked in the optional The Bridge accessory. During the installation process, you may program the codes for each of your source components into the remote. Each time you wish to use the codes for any component, first press the Selector button for that component. This changes the button functions to the appropriate codes for that product.

NOTE: Several of the Input Selectors are shared between two devices. The selector button will light in red when the remote is in the device mode printed on the button, and it will light in green for the device mode printed above the button. To switch between the two device modes, press the selector *twice* quickly in succession. The selector will remain in the last-selected mode until the next time you press the selector twice quickly.

For example, the first time you press the DVD button, the button will light up in red, indicating that the remote is in DVD mode. If you press another selector, such as the VID3 selector, and then press the DVD button again, the DVD button will remain red, indicating the remote is still in DVD mode. Now press the DVD button twice quickly. At the first press the button will light red, indicating that the remote is in DVD mode. On the second press the button will turn green, indicating that the remote is now in CD mode. If you press a different selector and return to the DVD/CD Selector, you will observe that the remote is still in CD mode.

Each Input Selector has been preprogrammed to control certain types of components, with only the codes specific to each brand and model changing, depending on which product code is programmed. The device types programmed into each selector may not be changed; however you may program the HDMI 1 and 2 selectors with the DVD, Cable/Satellite or VCR/PVR device type.

DVD: Controls DVD players and recorders.

CD: Controls CD players and recorders.

Tape: Controls cassette decks.

Video 1: Controls VCRs, TiVo® and PVRs.

Video 2: Controls cable and satellite television set-top boxes.

Video 3: Controls televisions and other video displays.

Video 4: Controls televisions and other video displays.

HDMI 1 and 2: Each code set controls a source device (VCR/PVR, DVD player or cable/satellite set-top box) connected to one of these two inputs.

XM: Controls the AVR functions for XM Satellite Radio.

The Bridge/DMP: Controls an iPod docked in The Bridge.

Any given button may have different functions, depending on which component is being controlled. Some buttons are labeled with these functions. For example, the Sleep and DSP Surround Buttons are labeled for use as Channel Up/Down Buttons when controlling a television or cable box. See Table A8 in the appendix for listings of the different functions for each type of component.

IR Transmitter Lens: As buttons are pressed on the remote, infrared codes are emitted through this lens. Make sure it is pointing toward the component being operated.

Power On Button: Press this button to turn on the AVR or another device. The Master Power Switch on the AVR 347's front panel must first have been switched on.

Mute Button: Press this button to mute the AVR 347's speaker and headphone outputs temporarily. To end the muting, press this button or adjust the volume. Muting is also canceled when the receiver is turned off.

Program Indicator: This LED lights up or flashes in one of three colors as the remote is programmed with codes.

Power Off Button: Press this button to turn off the AVR 347 or another device.

AVR Selector: Press this button to switch the remote to the codes that operate the receiver.

Input Selectors: Press one of these buttons to select a source device, which is a component where a playback signal originates, e.g., DVD, CD, cable TV, satellite or HDTV tuner, or an iPod docked in the optional The Bridge. This will also turn on the receiver and switch the remote's mode to operate the source device.

XM Radio Button: Press this button to select XM Satellite Radio as the source. You will need to have purchased and activated an XM antenna module, and you will also need to subscribe to the XM Radio service. Visit www.xmradio.com for more information.

AM/FM Button: Press this button to select the tuner as the source, or to switch between the AM, FM and XM Radio bands.

6-/8-Channel Input Selector: Press this button to select the 6-/8-Channel Inputs as the audio source. The receiver will use the video input and remote control codes for the last-selected video source.

Learn Button: The AVR 347 remote is capable of "learning" individual IR codes from the original remote that came with your TV or a device that is connected to any of the source inputs. See the Advanced Functions section for instructions on learning remote codes.

Test Tone: Press this button to activate the test tone for manual output-level calibration.

TV/Video: This button has no effect on the receiver, but is used to switch video inputs on some video source components.

Sleep Button: Press this button to activate the sleep timer, which turns off the receiver after a programmed period of time of up to 90 minutes.

Volume Controls: Press these buttons to raise or lower the volume, which will be shown in decibels (dB) in the Message Display.

DSP Surround: Press this button to select a DSP surround mode (Hall 1, Hall 2, Theater).

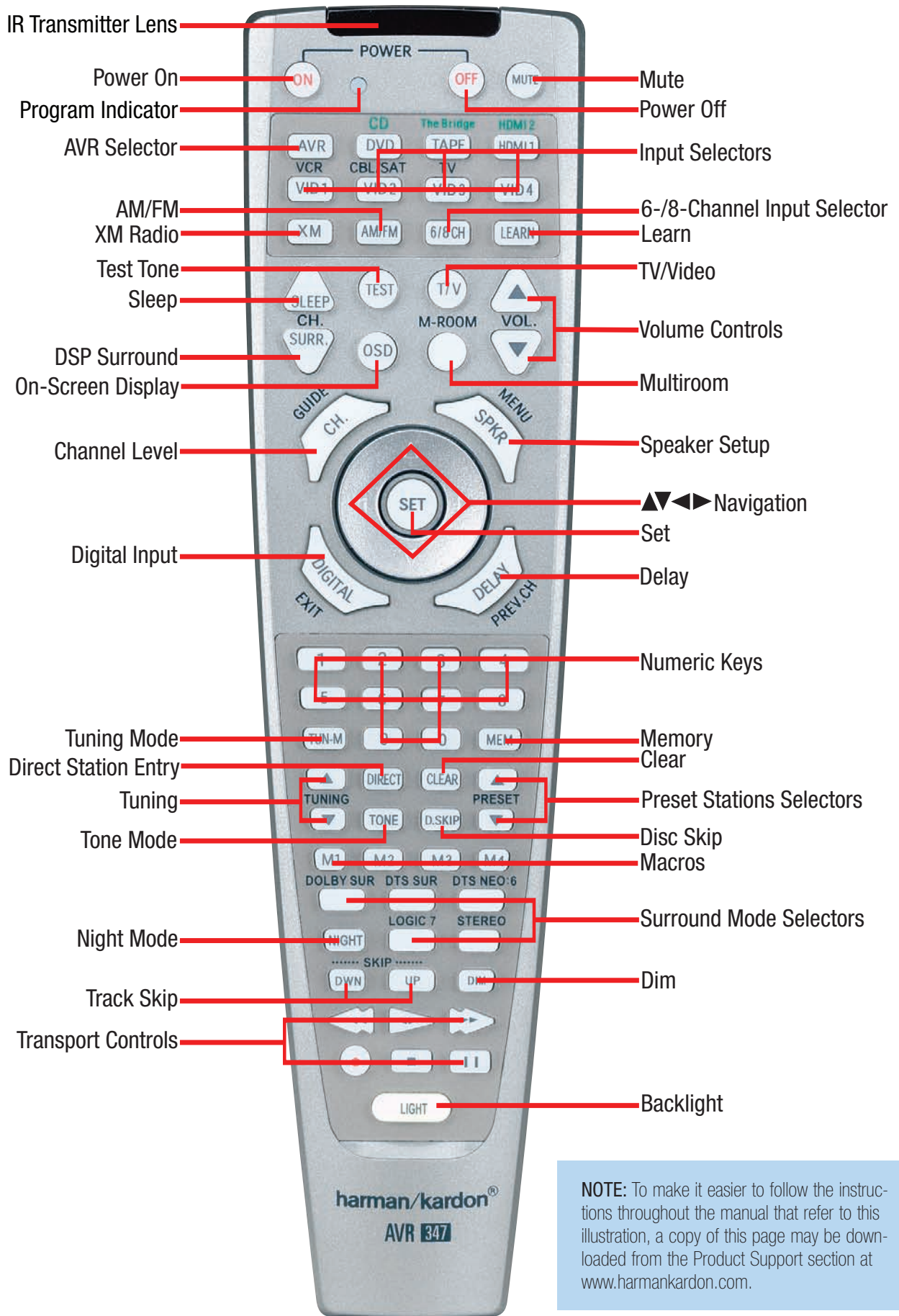

NOTE: To make it easier to follow the instructions throughout the manual that refer to this illustration, a copy of this page may be downloaded from the Product Support section at www.harmankardon.com.

MAIN REMOTE CONTROL FUNCTIONS

On-Screen Display (OSD): Press this button to activate the on-screen menu system.

Multiroom: Press this button to control the multiroom system. Three settings are available: MULTI ON/OFF, which is used to turn the multiroom system on or off; MULTI LEVEL, which adjusts the volume of the remote zone only; and MULTI INPUT, which is used to select the source input for the remote zone. See Multiroom Operation in the Advanced Functions section for more information on using the AVR 347's multiroom system.

Channel Level: Press this button to adjust the output levels for each channel so that all speakers sound equally loud at the listening position. Usually this is done while playing an audio selection, such as a favorite CD, after you have calibrated the levels using EzSet/EQ, as described in the Initial Setup section.

Speaker Setup: Press this button to configure speaker sizes, that is, the low-frequency capability of each speaker. Usually this is done using the on-screen menu system, as described in the Initial Setup section.

Navigation (▲/▼/◀/▶) and Set Buttons: These buttons are used to make selections within the on-screen menu system, or when accessing the functions of the four buttons surrounding this area of the remote – Channel Level, Speaker Setup, Digital Input or Delay.

Digital Input Select: Press this button to select the specific digital audio input (or analog audio input) you used for the current source.

Delay: Press this button to set delay times that compensate for placing the speakers at different distances from the listening position, or to resolve a "lip sync" issue that may be caused by digital video processing. This may also be done using the on-screen menu system, as described in the Initial Setup section.

Numeric Keys: Use these buttons to enter radio station frequencies or to select station presets. When the AM or FM band is in use, press the Direct button before entering the station frequency.

When listening to XM Radio, you may enter channel numbers without first pressing the Direct Button; however, use the Preset Stations Selectors to access the preset stations. To access another bank of XM presets, press the Set Button repeatedly until PRESET SEARCH appears, then use the ▲/▼ Buttons to select the letter of the desired bank.

Tuning Mode: When listening to AM or FM radio, this button toggles between manual (one frequency step at a time) and automatic (seeks frequencies with acceptable signal strength) tuning mode. It also toggles between stereo and mono modes when an FM station is tuned.

When listening to XM Radio, press the Tuning Mode Button once to view the category name of the current channel. Additional presses will display the artist, song title and channel name.

Memory: After you have tuned a particular radio station, press this button, then the numeric keys, to save that station as a radio preset.

For XM Radio, the procedure for saving a preset is a little different. To save the current channel in one of the 40 available preset locations,

press the Set Button repeatedly until PRESET SEARCH appears. Use the ▲/▼ Buttons to select a letter (A through E) representing one of the five banks of preset memory slots. Then press the Memory Button, followed by a Numeric Key (1 through 8) for the precise preset memory location you wish to save the channel in.

Tuning: Press these buttons to tune a radio station or XM Radio channel. For the AM and FM bands, and depending on whether the tuning mode has been set to manual or automatic, each press will either change one frequency step at a time, or seek the next frequency with acceptable signal strength.

Direct: Press this button before using the Numeric Keys to directly enter a radio station frequency (AM or FM bands only).

Clear: Press this button to clear a radio station frequency you have started to enter.

Preset Stations Selector: Press these buttons to select a preset radio station.

For XM Radio, first press the Set Button repeatedly until PRESET SEARCH appears and then use the ▲/▼ Buttons to select the letter of the desired bank of presets.

Tone Mode: Press this button to access the tone controls (bass and treble). Use the Navigation Buttons to make your selections.

Disc Skip: This button has no effect on the receiver, but is used with some optical disc changers to skip to the next disc.

Macros: These buttons may be programmed to execute long command sequences with a single button press. They are useful for programming the command to turn on or off all of your components, or for accessing specialized functions for a different component than you are currently operating.

Surround Mode Selectors: Press any of these buttons to select a type of surround sound (e.g., multichannel) mode. Choose from the Dolby modes, DTS modes, Logic 7 modes or Stereo modes. Each press of a button will cycle to the next available variant of that mode. Not all modes or mode groups are available with all sources.

Night Mode: Press this button to activate Night mode with specially encoded Dolby Digital discs or broadcasts. Night mode compresses the audio so that louder passages are reduced in volume to avoid disturbing others, while dialogue remains intelligible.

Track Skip: These buttons have no effect on the receiver, but are used with many source components to change tracks or chapters.

Dim: Press this button to partially or fully dim the front-panel display.

Transport Controls: These buttons have no effect on the receiver, but are used to control many source components. By default, when the remote is operating the receiver, these buttons will control a DVD player.

Backlight: Press this button to illuminate the buttons on the remote. Press it again to turn the backlight off, or wait five seconds after the last button press for the light to turn off on its own.

CONNECTIONS

There are different types of audio and video connections used to connect the receiver to the speakers and video display, and to connect the source devices to the receiver. To make it easier to keep them all straight, the Consumer Electronics Association (CEA®) has established a color-coding standard. Table 1 may be helpful to you as a reference while you set up your system.

Table 1 – Connection Color Guide

Audio Connections	
	Left Right
Front (FL/FR)	White Black
Center (C)	Green
Surround (SL/SR)	Blue Grey
Surround Back (SBL/SBR)	Brown Orange
Subwoofer (SUB)	Purple
Digital Audio Connections	
Coaxial	Orange
Optical	Input Output
Video Connections	
Component	Y Green Pb Blue Pr Red
Composite	Yellow
S-Video	Black
HDMI™ Connections (digital audio/video)	
HDMI	Black

Types of Connections

This section will briefly review different types of cables and connections that you may use to set up your system.

Speaker Connections

Speaker cables carry an amplified signal from the receiver's speaker terminals to each loudspeaker. Speaker cables contain two wire conductors, or leads, inside plastic insulation. The two conductors are usually differentiated in some way, by using different colors, or stripes, or even by adding a ridge to the insulation. Sometimes the actual wires are different, one being copper-colored and the other silver.

The differentiation is important because each speaker must be connected to the receiver's speaker-output terminals using two wires, one positive (+) and one negative (-), referred to as speaker polarity. It's important to maintain the proper polarity for all speakers in the system. If some speakers have their negative terminals connected to the receiver's positive terminals, performance can suffer, especially for the low frequencies.

Always connect the positive terminal on the loudspeaker, which is usually colored red, to the positive terminal on the receiver, which is colored as shown in the Connection Color Guide (Table 1). Similarly, always connect the black negative terminal on the speaker to the black negative terminal on the receiver.

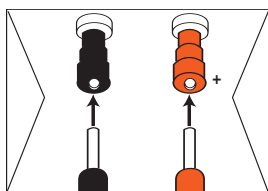

The AVR 347 uses binding-post speaker terminals that can accept banana plugs or bare-wire cables. Banana plugs are simply plugged into the hole in the middle of the terminal cap. See Figure 1.

Figure 1 – Binding-Post Speaker Terminals With Banana Plugs

Bare wire cables are installed as follows (see Figure 2):

1. Unscrew the terminal cap until the pass-through hole in the collar is revealed.
2. Insert the bare end of the wire into the hole.
3. Hand-tighten the cap until the wire is held snugly.

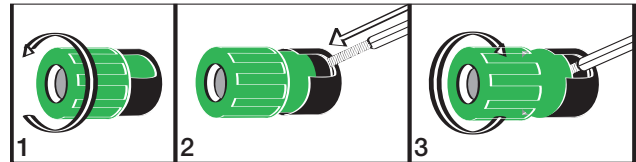

Figure 2 – Binding-Post Speaker Terminals With Bare Wires

Subwoofer

The subwoofer is a specialized type of loudspeaker that is usually connected in a different way. The subwoofer is used to play only the low frequencies (bass), which require much more power than the other speaker channels. In order to obtain the best results, most speaker manufacturers offer powered subwoofers, in which the speaker contains its own amplifier on board. Sometimes the subwoofer is connected to the receiver using the front left and right speaker outputs, and then the front left and right speakers are connected to terminals on the subwoofer. More often, a line-level (nonamplified) connection is made from the receiver's Subwoofer Output to a corresponding jack on the subwoofer, as shown in Figure 3.

Although the subwoofer output looks similar to the analog audio jacks used for the various components, it is filtered and only allows the low frequencies to pass. Don't connect this output to any other devices. Although doing so won't cause any harm, performance will suffer.



Figure 3 – Subwoofer

Connecting Source Devices to the AVR

The AVR 347 is designed to process audio and video input signals, playing back the audio and displaying the video on a television or monitor connected to the AVR. These signals originate in what are known as "source devices," including your DVD player, CD player, DVR (digital video recorder) or other recorder, tape deck, game console, cable or satellite television box or MP3 player. Although the tuner is built into the AVR, it also counts as a source, even though no external connections are needed, other than the FM and AM antennas and the XM antenna module.

Separate connections are required for the audio and video portions of the signal, except for digital HDMI connections. The types of connections used depend upon what's available on the source device, and for video signals, the capabilities of your video display.

CONNECTIONS

Audio Connections

There are two formats for audio connections: digital and analog. Digital audio signals are of higher quality, and are required for listening to sources encoded with digital surround modes, such as Dolby Digital and DTS. There are three types of digital audio connections: HDMI, coaxial and optical. Any one type of digital audio connection may be used for each source device, but never more than one for the same source. However, it's okay to make both analog and digital audio connections at the same time to the same source.

NOTE: Since the AVR 347 is capable of processing the audio and video portions of most HDMI signals, if your video display device has an HDMI input, you may make a single HDMI connection from your HDMI 1.1-or-higher source device (such as a DVD player) to the AVR. In that case, no separate digital audio connection is required. Make sure to turn the volume on your television all the way off.

Digital Audio

The AVR 347 is equipped with two HDMI (High-Definition Multimedia Interface) inputs, and one output. HDMI is capable of carrying digital audio and video information using a single cable, thus delivering the highest possible quality picture and sound.

The AVR 347 is Simplay HD-verified for compatibility via the HDMI connection with other Simplay HD-verified products.

There are different versions of HDMI, depending on the capability of the source device and the type of signal it is capable of transmitting via the HDMI connection.

In addition, receivers and processors such as the AVR 347 may handle the incoming signal in several different ways, depending on their capability as well. Thanks to its powerful processor, the AVR 347 is capable of processing both the audio and video components of the HDMI data, minimizing the number of cable connections in your system.

NOTE: Some multichannel audio devices, such as DVD-Audio, SACD, HD-DVD or Blu-ray Disc players, output some audio formats only through the source's multichannel analog outputs. These include DVD-Audio players with HDMI version 1.0, and HD-DVD and Blu-ray Disc players that do not decode the digital audio. In those cases, make a separate analog audio connection in addition to the HDMI connection, which is still used for video or if you wish to listen to Dolby Digital, DTS or PCM materials that may be stored on the disc.

In addition, the AVR 347 will convert analog video signals to the HDMI format, upscaling to high-definition 720p resolution. Source signals with 1080i or 1080p resolution are passed via the HDMI Output to your display at their original high-quality resolution, depending on your display's capabilities. You may view the AVR 347's own on-screen display menu using the HDMI output.

IMPORTANT NOTE: The AVR 347 cannot convert 1080i or 1080p analog video signals to the HDMI format, and downconverts them to 720p for the Component Video Outputs. This affects users of Microsoft® Xbox® 360 systems and some older set-top boxes.

If your digital cable television set-top box outputs 1080i or better video via component video outputs and is not equipped with an HDMI output, contact your cable operator for a replacement.

For Xbox 360 and satellite television customers, either change the settings on your source device to ensure that it outputs only 720p video through its component video outputs, which the AVR can convert to the HDMI format, or connect the AVR's Component Video Monitor Outputs to the video display. Although you could connect the source device's component video outputs directly to your video display, you would then have to select the correct video input on the display, depending on which source input on the AVR was in use.

The physical HDMI connection is simple. The connector is shaped for easy plug-in (see Figure 4). If your video display has a DVI input, you may use an HDMI-to-DVI adapter (not included) to connect it to the AVR's HDMI Output.



Figure 4 – HDMI Connection

HDMI cable runs are usually limited to about 10 feet. The AVR 347 incorporates a repeater, which allows an additional 10 feet of cable between the source device and the video display.

If your video display or source device is not HDMI-capable, use one of the analog video connections (composite, S- or component video) and if available on your source device, either a coaxial or optical digital audio connection.

Coaxial digital audio jacks are usually color-coded in orange. Although they look similar to analog jacks, they should not be confused, and you should not connect coaxial digital audio outputs to analog inputs or vice versa. See Figure 5.



Figure 5 – Coaxial Digital Audio

Optical digital audio connectors are often covered by a shutter to protect them from dust. The shutter opens as the cable is inserted. Input connectors are color-coded using a black shutter, while outputs use a gray shutter. See Figure 6.



Figure 6 – Optical Digital Audio

Due to the nature of digital signals as binary bits, they aren't subject to signal degradation the way analog signals are. Therefore, the quality of all digital audio connections should be the same, although it is important to limit the length of the cable. Whichever type of connection you choose, Harman Kardon recommends that you always select the highest quality cables available within your budget.

CONNECTIONS

Analog Audio

Analog connections require two cables, one for the left channel (white) and one for the right channel (red). These two cables are often attached to each other for most of their length. See Figure 7.

Most sources that have digital audio jacks also have analog audio jacks, although some older types of sources, such as tape decks, have only analog jacks. For sources that are capable of both digital and analog audio, you may wish to make both connections.

The analog audio connection is strongly recommended if you intend to use the source with the multiroom system. It's required if you will be using the multiroom preamp outputs with an external amplifier to power your remote speakers, as the AVR 347's multiroom system is not capable of converting the digital signal to analog format. It's suggested that you also use the analog audio connections when using the surround back/multiroom speaker outputs, in case another two-channel digital audio source is in use in the main listening area. The AVR 347 is only capable of processing one PCM source at a time.

If you wish to record materials from DVDs or other copy-protected sources, you may only do so using analog connections. Remember to comply with all copyright laws, if you choose to make a copy for your own personal use.



Figure 7 – Analog Audio

Multichannel analog connections are used with some high-definition sources where the copy-protected digital content is decoded inside the source. These types of connections are usually used with DVD-Audio, SACD, Blu-ray Disc, HD-DVD and other multichannel players. See Figure 8. However, the multichannel analog audio connection is not required for DVD-Audio players compliant with HDMI version 1.1 or better, or HD-DVD and Blu-ray Disc players that decode the digital audio internally and output linear PCM signals in digital format. Consult the owner's guide for your disc player for more information.

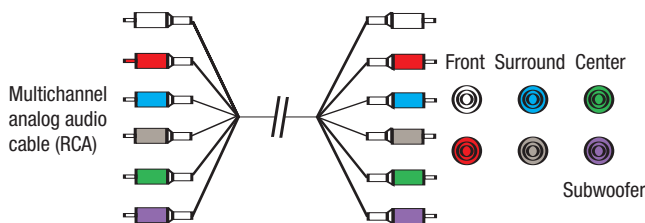

Figure 8 – Multichannel Analog Audio

Harman Kardon receivers also include a proprietary, dedicated audio connection called "The Bridge/DMP". If you own an iPod with a dock connector, you may separately purchase The Bridge and connect it to The Bridge/DMP port on the receiver. See Figure 9. Dock your iPod (not included) in The Bridge, and you may listen to your audio materials through your high-performance audio system. If your iPod is photo- or video-capable, you may view still images or video materials stored on the iPod using your home theater system. You may even use the

AVR 347 remote to control the iPod, with navigation messages displayed on the front panel and on a video display connected to the AVR. The Bridge outputs analog audio to the AVR 347, and it is available to the multiroom system.



Figure 9 – The Bridge

Video Connections

Although some sources produce an audio signal only (e.g., CD player, tape deck), many sources output both audio and video signals (e.g., DVD player, cable television box, HDTV tuner, satellite box, VCR, DVR). In addition to the audio connection, you will need to connect one type of video connection for each source (never more than one at the same time for any source).

Digital Video

If you have already connected a source device to one of the HDMI inputs as explained in the Digital Audio Connections section, then you have automatically made a video connection at the same time, as the HDMI signal includes both digital audio and video components.

If the source device is not capable of transmitting its digital audio signal through the HDMI connection, then use one of the coaxial or optical digital audio inputs for the source.

If a multichannel analog audio connection is required for certain lossless formats (e.g., DVD-Audio, SACD, HD-DVD or Blu-ray Disc), you may make both connections, but you must also make an analog video connection. To listen to the multichannel disc, first select the analog video source input, then select the 6-/8-channel analog audio inputs, and the AVR will retain the last video source you selected other than HDMI.

The AVR 347 is Simplay HD-verified for compatibility via the HDMI connection with other Simplay HD-verified products.



Figure 4 (repeated) – HDMI Connection

Analog Video

There are three types of analog video connections: composite video, S-video and component video. Composite video is the basic connection most commonly available. The jack is usually color-coded yellow, and looks like an analog audio jack, although it is important never to confuse the two. Do not plug a composite video cable into an analog or coaxial digital audio jack, or vice versa. Both the chrominance (color) and luminance (intensity) components of the video signal are transmitted using a single cable. See Figure 10.



Figure 10 – Composite Video

S-video, or "separate" video, transmits the chrominance and luminance components using separate wires contained within a single cable. The

CONNECTIONS

plug on an S-video cable contains four metal pins, plus a plastic guide pin. Be careful to line up the plug correctly when you insert it into the jack on the receiver, source or video display. See Figure 11.



Figure 11 – S-Video

Component video separates the video signal into three components – one luminance (“Y”) and two sub-sampled color signals (“Pb” and “Pr”) – that are transmitted using three separate cables. The “Y” cable is color-coded green, the “Pb” cable is colored blue and the “Pr” cable is colored red. See Figure 12.

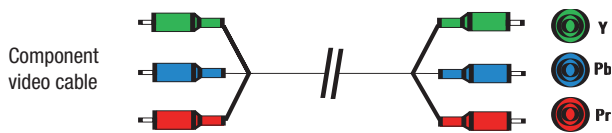

Figure 12 – Component Video

If it's available on your video display, HDMI is recommended as the best quality connection, followed by component video, S-video and then composite video.

NOTES:

- Due to copy-protection restrictions, there is no output at the Component Video Monitor Outputs for copy-protected sources.
- High-resolution 1080i and 1080p video signals are not available at the HDMI Output, and are downconverted to 720p for the Component Video Outputs. If your source outputs analog high-resolution video, either use the Component Video Outputs, change the output resolution of your source device to 720p, or connect your source's component video outputs directly to your video display.
- Due to the design of some video displays, analog 480p or 720p component video source signals may produce artifacts when used with the AVR's analog video outputs (composite, S-video or component video). If this occurs, try changing the Video Mode setting in the INPUT SETUP menu, or connecting the source device's video output directly to your video display. However, for best results, we recommend that you consider upgrading to an HDMI-capable video display.

Antennas

The AVR 347 uses separate terminals for the included FM and AM antennas that provide proper reception for the tuner.

The FM antenna uses a 75-ohm F-connector. See Figure 13.

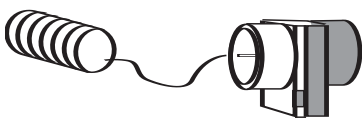

Figure 13 – FM Antenna

The AM loop antenna needs to be assembled. Then connect the two leads to the screw terminals on the receiver. See Figure 14.

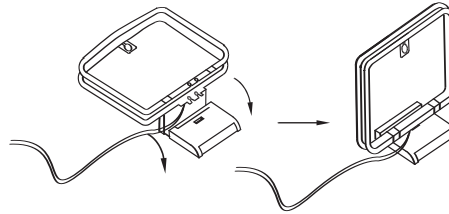

Figure 14 – AM Antenna

RS-232 Serial Port

The RS-232 serial port on the AVR 347 is used only for data. If Harman Kardon releases a software upgrade for the receiver's operating system at some time in the future, the upgrade may be downloaded to the AVR using this port. Complete instructions will be provided at that time.

INSTALLATION

You are now ready to connect your various components to your receiver. Before beginning, make sure that all components, including the AVR 347, are turned completely off and their power cords are unplugged. **Don't plug any of the power cords back in until you have finished making all of your connections.**

Remember that your receiver generates heat while it is on. Select a location that leaves several inches of space on all sides of the receiver. It is preferable to avoid completely enclosing the receiver inside a cabinet. It is also preferable to place components on separate shelves rather than stacking them directly on top of the receiver. Some surface finishes are delicate. Try to select a location with a sturdy surface finish.

Step One – Connect the Speakers

If you have not yet done so, place your speakers in the listening room, as described in the Speaker Placement section above.

Connect the center, front left, front right, surround left, surround right, surround back left and surround back right loudspeakers to the corresponding speaker terminals on the AVR 347. See Figure 17. Remember to maintain the proper polarity by always connecting the positive and negative terminals on each speaker to the positive and negative terminals on the receiver. Use the Connection Color Guide on page 19 as a reference.

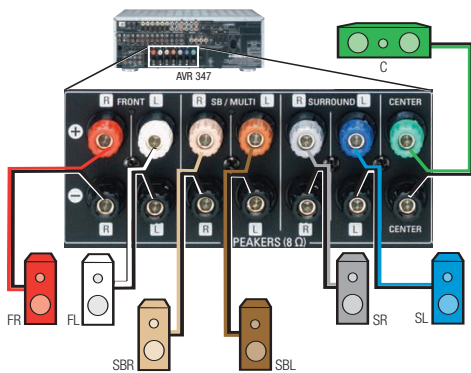

Figure 17 – Speaker Connections

NOTE: If you only have one surround back speaker, wait until after you have run EzSet/EQ in the Initial Setup section before connecting it to the Surround Back Left speaker outputs.

Step Two – Connect the Subwoofer

Connect the Subwoofer Output on the AVR 347 to the line-level input on your subwoofer. See Figure 18. Consult the manufacturer's guide for the subwoofer for additional information.

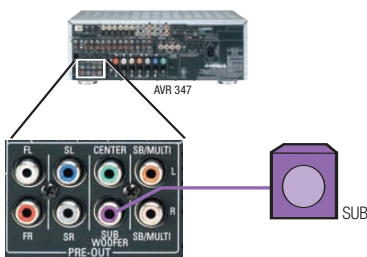

Figure 18 – Subwoofer Connection

Step Three – Connect the Antennas

Connect the FM and AM antennas to their terminals. If you have purchased an XM antenna module designed for connection to an XM Ready device, such as the AVR 347, you may connect it now. To enjoy XM Radio, remember to purchase a subscription and activate your antenna module. More information is available at www.xmradio.com. See Figure 19.

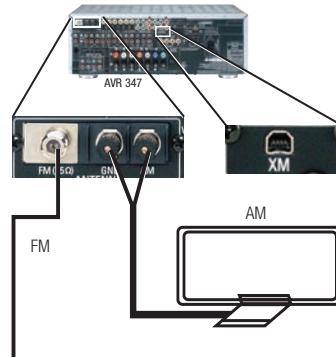

Figure 19 – Antenna Connections

Step Four – Connect the Source Components

Use the Table A4 worksheet in the Appendix to note which connections you will use for each of your source devices.

For each source, select a source input (Video 1, Video 2, Video 3, etc.). In Table 2 we recommend connecting certain types of sources to certain source inputs to make it easier to program and use the remote control.

Decide which audio connections you will use. If your source device has them, use *one of* the HDMI, coaxial digital or the optical digital audio connection. Referring to Table 2, we recommend that you connect the DVD source to the Coaxial 1 input jack, and the source designated Video 2 to the Optical 1 input jack. If you are using the HDMI inputs, then in most cases no other audio connection is required. If your source outputs video but not audio via its HDMI connection, then select any available digital audio input on the AVR to use with the source. If your HDMI source plays DVD-Audio, SACD, HD-DVD, Blu-ray Discs or another multichannel audio format, connect its multichannel analog audio outputs to the AVR 347's 6-/8-Channel Inputs, and connect one of its analog video outputs to a source input on the AVR 347 (e.g., Component Video 3 or Video 3). When you select that source input, e.g., Video 3, select the 6-/8-Channel Inputs, and the AVR will automatically use the analog video input.

NOTE: The multichannel analog audio connection is not required for DVD-Audio players compliant with HDMI version 1.1 or better, or HD-DVD and Blu-ray Disc players that decode the digital audio internally and output linear PCM signals in digital format. Consult the owner's guide for your disc player for more information.

In addition to the digital audio connections, we recommend that you connect the analog audio connections for each source, as a backup to the digital connections, for recording, for use with the multiroom system, or in the event that you use all eight of the digital audio inputs for other devices. For sources that don't have digital audio outputs, you must use the analog audio connections.

INSTALLATION

For each video source, select one type of video connection. HDMI video is preferred, but both your source device and your video display must have this type of video capability. If either device does not, then use component video, S-video or composite video.

Referring to Table 2, we recommend that you connect the DVD source to the Component Video 1 inputs, the Video 1 source to the Component Video 2 inputs, and the Video 2 source to the Component Video 3 inputs. Any HDMI-capable source devices should be connected to one of the two HDMI inputs. All other source devices should be connected to either the component, S- or composite video input for that source. However, you may make whatever video connections are best for your system.

NOTE: It's possible for a source to use none of the connections named for that source. For example, you might connect your DVD player to the Component Video 1 inputs and the Coax 1 digital audio input. However, we will refer to this source as "DVD," and in the Initial Setup section you will program the receiver so that these connections are assigned to the DVD source. When you select "DVD" as your source using the front panel or the remote, the correct connections for your DVD player will be used.

We recommend connecting your various sources using the connections shown in Table 2 (below) in order to simplify programming your receiver and remote control. However, you may connect any device to any source input.

Table 2 – Recommended Source Component Connections

Source Device Type	AVR 347 Source Input	Audio Connections	Video Connections
VCR, DVR, PVR, TiVo or other audio/video recorder	Video 1	<ul style="list-style-type: none"> Video 1 Analog (inputs and outputs) and Any one available coaxial or optical digital, audio input, with corresponding coax or optical digital output 	<ul style="list-style-type: none"> One of Component Video 2, Video 1 S-video or Video 1 Composite Video Input For recording, use Video 1 S-video or Composite Video Output, and do not use component video connections at all
Cable TV, satellite TV, HDTV or other device that delivers television programs	Video 2	<ul style="list-style-type: none"> Video 2 Analog Inputs and Optical 1 Input 	<ul style="list-style-type: none"> One of Component Video 3, Video 2 S-video or Video 2 Composite Video Input
TV or other audio/video device (only when used as a source)	Video 3	<ul style="list-style-type: none"> Video 3 Analog Inputs and Any one available coaxial or optical digital audio input 	<ul style="list-style-type: none"> Video 3 S-video or Video 3 Composite Video Input Not required if source is a TV
TV, game console, camera or other audio/video device	Video 4 (front-panel jacks)	<ul style="list-style-type: none"> Video 4 Analog Inputs and Either Coax 3 or Optical 3 Input 	<ul style="list-style-type: none"> Video 4 S-video or Video 4 Composite Video Input Not required if source is a TV
DVD Audio/Video, SACD, HD-DVD, Blu-ray Disc	DVD	<ul style="list-style-type: none"> DVD Analog Inputs 6-/8-Channel Inputs (optional) and Coax 1 Input 	<ul style="list-style-type: none"> Component Video 1 Input
HDMI-capable DVD Audio/Video or HD-DVD player or other audio/video device	HDMI 1	<ul style="list-style-type: none"> HDMI 1 Input 6-/8-Channel Inputs (optional) 	<ul style="list-style-type: none"> HDMI 1 Input
HDMI-capable DVD Audio/Video or HD-DVD player or other audio/video device	HDMI 2	<ul style="list-style-type: none"> HDMI 2 Input 6-/8-Channel Inputs (optional) 	<ul style="list-style-type: none"> HDMI 2 Input
CD player	CD	<ul style="list-style-type: none"> CD Analog Inputs and Any one available coaxial or optical digital audio input 	<ul style="list-style-type: none"> Not required
CDR, MiniDisc, cassette	Tape	<ul style="list-style-type: none"> Tape Analog (inputs and outputs) and Any one available coaxial or optical digital, audio input, with corresponding output or optical digital output 	<ul style="list-style-type: none"> Not required

INSTALLATION

NOTE: The AVR 347 is equipped with a total of eight digital audio inputs, not including the HDMI inputs: six on the rear panel (Coaxial 1, 2 and 3, Optical 1, 2 and 3) and two on the front panel (Coaxial 4 and Optical 4). However, there are a total of nine sources that may be connected to devices that have digital audio outputs. We recommend certain digital audio connections simply because, as reflected in Table A1 of the Appendix, those digital audio inputs are assigned to those sources by default at the factory. But any digital audio input (except HDMI) may be reassigned to any source. Since you may not be using all nine source inputs, you may reassign a digital audio input that is recommended for a source you aren't using to another device. Table 2 is a guide; you may need to make adjustments to fit your system.

Video 1 Source

Since this source includes audio and video recording output jacks, it is best suited to a video recorder, such as your VCR or DVR/PVR.

Referring to Table 2, connect your recorder to the Video 1 Analog Audio inputs and outputs **and** to any available coaxial or optical digital audio input (and corresponding digital audio output). See Figure 20. Use either the Video 1 S-video or composite video input and output if you wish to make recordings. If you don't plan on recording, you may use the Component Video 2 inputs.



Figure 20 – Video 1 AV Inputs and Outputs, and Digital Audio Inputs and Outputs

Remember to connect the audio and video *output* jacks on your recorder to the Video 1 or digital audio *input* jacks on the AVR, and the audio and video *input* jacks on your recorder to the Video 1 or digital audio *output* jacks on the AVR.

NOTE: It isn't possible to make recordings using component video or HDMI connections. Keep this in mind as you connect other source devices that you may wish to make recordings from.

Video 2 Source

The Video 2 source is used only for playback. The AVR 347 remote control is programmed to operate many brands and models of cable and satellite television devices, and we recommend connecting your cable or satellite set-top box to this source.

Referring to Table 2, connect your set-top box to the Video 2 Analog Audio inputs **and** to the Optical 1 Digital Audio input. If possible, use the Component Video 3 inputs. Otherwise, connect the set-top box's S-video or composite video output to the matching Video 2 video input. See Figure 21.



Figure 21 – Video 2 AV, Digital Audio and Component Video Inputs

Video 3 Source

The Video 3 source is used for playback only. The remote control is programmed to operate a TV, but you may connect any audio/video source device to the Video 3 inputs and use the device's own remote to control it.

If you receive your television programming using your TV with an antenna or direct cable connection, connect the analog audio outputs (if available on your TV) to the Video 3 Analog Audio inputs. See Figure 22. *Do not* connect any video output on the television set to any video input on the receiver. See Step Five for information on connecting the receiver's video monitor outputs to the TV.

NOTE: You may connect any video source other than a display device to the Video 3 S-video or composite video inputs.



Figure 22 – Video 3 AV Inputs

Video 4 Source

The Video 4 source is used only for playback. It is also generally reserved for components that are only temporarily connected to the receiver, such as cameras and game consoles. When not in use, you may place the supplied covers over the front-panel Video 4 jacks for a cleaner appearance. Simply snap the covers in place. When you wish to use the jacks, gently press on the left side of each cover to pivot it out for removal.

Referring to Table 2, connect your camera or game console to the Video 4 Analog Audio inputs **and** to either the Coaxial 4 or Optical 4 digital audio input. Connect the component's S-video or composite video output to the matching Video 4 video input. See Figure 23.



Figure 23 – Video 4 A/V and Digital Audio Inputs

NOTE: The Video 4 Input Selector on the remote may be programmed to operate a television or video display only.

INSTALLATION

IMPORTANT NOTE FOR MICROSOFT® XBOX® 360 USERS:

The Microsoft Xbox 360 gaming system is capable of outputting high-definition 1080i and 1080p video signals using the analog component video outputs. Since the AVR 347 is not capable of converting these analog component video signals to the HDMI format, and downconverts them to 720p for the Component Video Outputs, to view your Xbox 360's video output, either connect the Xbox's component video outputs to your video display, or change your Xbox 360's settings so that it outputs 720p video, which the AVR 347 can then convert to the HDMI format.

DVD

The DVD source is used for a DVD player. If you have a more advanced multichannel device, such as a Blu-ray Disc or HD-DVD player, you may connect it to the DVD source, or to one of the HDMI sources.

Referring to Table 2, connect your DVD player to the DVD Analog Audio inputs **and** to the Coaxial 1 Digital Audio input. If possible, use the Component Video 1 inputs. Otherwise, connect the DVD player's S-video or composite video output to the matching DVD video input. See Figure 24.



Figure 24 – DVD AV, Digital Audio and Component Video Inputs

If your DVD player plays multichannel lossless discs, such as SACD or DVD-Audio, or when an HD-DVD or Blu-ray Disc player is used, you may also need to connect the 6- or 8-channel analog audio outputs on the player to the 6-/8-channel analog audio inputs on the receiver, in order to enjoy these discs to their fullest. See Figure 25.



Figure 25 – 6-/8-Channel Analog Audio Inputs

NOTE: The multichannel analog audio connection is not required for DVD-Audio players compliant with HDMI version 1.1 or better, or HD-DVD and Blu-ray Disc players that decode the digital audio internally and output linear PCM signals in digital format. Consult the owner's guide for your disc player for more information.

HDMI 1 and 2

The HDMI sources are used with devices that are capable of outputting digital, audio and video through an HDMI connection, such as an HD-DVD or Blu-ray Disc player or HDTV tuner. The HDMI 1 and 2 sources are not used with any of the 2-channel analog audio or video inputs on the AVR 347.

Make sure your video display is HDMI-capable, and for many source devices, the display must be HDCP-compliant (High-Bandwidth Digital

Content Protection) in order to display copy-protected materials. If the source device is not capable of outputting digital audio via its HDMI output, connect its coaxial or optical digital audio output to an available input on the AVR. If the source device plays multichannel discs (e.g., DVD-Audio, SACD, HD-DVD, Blu-ray Disc), connect its multichannel analog audio outputs to the AVR 347's 6-/8-Channel Inputs (but see note above). Connect one of the source's analog video outputs to a source input on the AVR (e.g., Component Video 3 or Video 3) and select that source input, then select the 6-/8-Channel Inputs for audio; the AVR 347 will retain the last video selection other than HDMI. See Figure 26.

The AVR 347 is Simplay HD-verified for compatibility via the HDMI connection with other Simplay HD-verified products.

If your video display is equipped with a DVI (Digital Video Interface) input, you may use an HDMI-to-DVI adapter (not included).



Figure 26 – HDMI and Digital Audio Inputs

CD

The CD source is used for a strictly audio device, such as a CD player.

Referring to Table 2, connect your CD player to the CD Analog Audio inputs **and** to any available digital audio input. See Figure 27.



Figure 27 – CD Audio Inputs and Digital Audio Inputs

No video connections are needed.

Tape

The Tape source is used for audio-only recorders, such as a CDR, MiniDisc or cassette deck.

Referring to Table 2, connect your recorder to the Tape Analog Audio inputs and outputs, and to any available digital audio input (and corresponding digital audio output). See Figure 28.



Figure 28 – Tape Audio Inputs and Outputs, and Digital Audio Inputs and Outputs

Remember to connect the *output* jacks on your recorder to the Tape or digital audio *input* jacks on the AVR, and the *input* jacks on your recorder to the Tape or digital audio *output* jacks on the AVR.

No video connections are needed.



With Harman Kardon's optional The Bridge, you can listen to audio or view videos stored on your iPod (not included), use your AVR 347

INSTALLATION

remote control to operate the iPod, and even charge the iPod while it's docked in The Bridge.

Simply plug the proprietary cable from The Bridge into the special The Bridge/DMP connector on the rear of the AVR 347. See Figure 29. Refer to the owner's manual for The Bridge to select the appropriate insert to match your iPod.



Figure 29 – The Bridge/DMP Connector

Step Five – Connect Video Display

Only video connections should be made between the receiver and your video display (TV), unless your TV is the source for your television programming (see Video 3 Source on page 26).

If you used an HDMI video connection for any of your sources, then connect the HDMI Output on the AVR to an HDMI input on your video display. See Figure 30. Consult the owner's guide for your television to learn the proper procedure for disabling or muting the audio. Unless you have a non-HDMI source device that outputs 1080i or higher video via an analog component video connection (see note below), no other video connections are required, thanks to the AVR 347's ability to transcode analog video signals to HDMI, and you may proceed to Step Six.

IMPORTANT NOTE: The AVR 347 cannot convert 1080i or 1080p analog video signals to the HDMI format and downconverts them to 720p for the Component Video Outputs. This affects users of Microsoft Xbox 360 systems and some older set-top boxes.

If your digital cable television set-top box outputs 1080i or higher video via component video outputs only contact your cable operator for a replacement unit equipped with an HDMI output.

For Xbox 360 or satellite receivers with no HDMI output, change the settings on your source device so that it outputs only 720p video through its component video outputs, which the AVR can convert to the HDMI format. Although you could connect the source device's component video outputs directly to your video display, you would then have to select the correct video input on the display to match the AVR's input.



Figure 30 – HDMI Output

If your television does not have HDMI or DVI video inputs, you will need to make a video connection for each type of video used for your sources.

First, determine what types of video your display is capable of handling. Component video is preferred, followed by S-video and then composite video. Ideally, this guided you in selecting the video connections for your sources.

Next, note which types of video connections you used for your source devices. Make sure you didn't use a better type of video connection for a source than your video display can handle. If so, disconnect the source and use a video connection that's compatible with your display.

If you used component video for any sources, connect the Component Video Monitor Outputs on the receiver to one set of component video inputs on your display. See Figure 31. The AVR 347 is able to transcode composite and S-video sources to component video. If your video display has component video inputs, then you need only to connect the Component Video Monitor Outputs and you may proceed to Step Six.



Figure 31 – Component Video Monitor Outputs

If you used S-video for any sources, connect the S-video Monitor output on the receiver to an S-video input on your display. See Figure 32. The AVR 347 converts composite video sources to S-video. If your video display has S-video inputs, then you need only to connect the S-Video Monitor Output and you may proceed to Step Six.

If you used composite video for any sources, but not component video or S-video, connect the Composite Video Monitor output on the receiver to a composite video input on the display. See Figure 32.



Figure 32 – S-Video and Composite Video Monitor Outputs

Consult the manual for your TV to make sure you understand how to select each video input.

Step Six – Plug in AC Power

Having made all of your wiring connections, it is now time to plug each component's AC power cord into a working outlet.

You may plug one device into the AC Switched Accessory Outlet on the rear of the AVR 347. See Figure 33. Make sure this device draws no more than 50 watts. The device should have its mechanical or master power switch turned on, and it will power on any time the AVR 347 is turned on.



Figure 33 – Switched AC Accessory Outlet

Before plugging the AVR 347's AC Power Cord into an electrical outlet, make sure that the Master Power Switch on the front panel is popped out so that the word OFF appears on its top. Gently press the button to turn the switch off. This will prevent the possibility of damaging the AVR in case of a transient power surge.

The AVR 347 is equipped with a detachable power cord. It allows you to fully wire your system before installing the AVR, which may be required for some in-wall entertainment centers or custom applications. The male end of the cord should be plugged into an unswitched AC power outlet, and the female end should be plugged into the receptacle on the AVR 347's rear panel. See Figure 34.

INSTALLATION



Figure 34 – AC Power Input

Step Seven – Insert Batteries in Remote

The AVR 347 remote control uses three AAA batteries, which are included.

To remove the battery cover located on the back of the remote, firmly press the ridged depression and slide the cover toward the top of the remote.

Insert the batteries, as shown in Figure 35, making sure to observe the correct polarity.

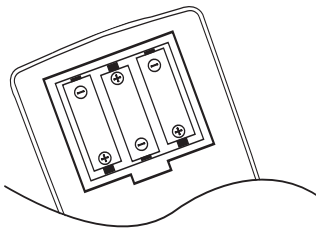

Figure 35 – Remote Battery Compartment

When using the remote, remember to point the lens toward the front panel of the AVR 347. Make sure no objects, such as furniture, are blocking the remote's path to the receiver. Bright lights, fluorescent lights and plasma video displays may interfere with the remote's functioning. The remote has a range of about 20 feet, depending on the lighting conditions. It may be used at an angle of up to 30 degrees to either side of the AVR.

If the remote seems to operate intermittently, or if pressing a button on the remote does not cause the AVR Selector or one of the Input Selectors to light up, then make sure the batteries have been inserted correctly, or replace all three batteries with fresh ones.

Step Eight – Program Sources Into the Remote

The AVR 347 remote not only is capable of controlling the receiver, but it may also be programmed to control many brands and models of VCRs, DVD players, CD players, cable boxes, satellite receivers, cassette decks and TVs, as well as an iPod docked in The Bridge.

It may help to think of the remote as a book with pages. Each "page" represents the button functions for a different device. In order to access the functions for a particular device, you first need to turn to that page; that is, switch the remote to that device mode. This is done by pressing the AVR Button to access the codes that control the receiver, or the Input Selector Buttons to access the codes for the devices programmed into the remote.

You may have noticed that three of the Input Selectors look different from the others (see Figure 36). For the DVD/CD, TAPE/The Bridge and HDMI 1/HDMI 2 Selectors, there is a primary source, the name of which is printed on the button, and a secondary source, the name of which is printed in green above the button.

When the remote is in the device mode for the primary source, e.g., DVD, pressing the device selector will cause it to light up in red. When the remote is in the secondary source's device mode, the selector will light up in green when pressed.

To switch between the primary and secondary device modes, press the selector twice quickly in succession. The selector will retain this selection until the next time you toggle between the primary and secondary device modes. That is, if you press the DVD/CD Selector twice quickly so that the CD source is activated, then press another source selector, such as Video 1, the next time you press the DVD/CD Selector, the remote will return to the CD device mode.

The AVR 347's remote is factory-programmed to control an iPod docked in The Bridge and many Harman Kardon DVD and CD players. If you have other source devices in your system, follow these steps to program the correct codes into the remote.

1. Using the codes in Tables A9–A16 of the Appendix, look up the product type (e.g., DVD, cable TV box) and the brand name of your source. The number(s) listed is/are potential candidates for the correct code set for your particular device.
2. Turn on your source device.
3. This step places the remote in program mode, and varies slightly, depending on which Input Selector is being programmed. Refer to Figure 36.
 - a) **DVD, Tape, Video 1, Video 2, Video 3 and Video 4 Sources:** Press and hold the Input Selector until the Program Indicator LED starts to flash, then release it. Follow the directions in Step 4, below.
 - b) **CD Source:** Press the DVD/CD Input Selector twice quickly so that it turns green, hold it until the Program LED starts to flash, then release. Follow the directions in Step 4, below.
 - c) **HDMI 1 Source:** Press and hold the Input Selector until it turns red and the Program LED flashes, then release it. Next, press the Input Selector that corresponds to the device type you want to program into the HDMI 1 mode, i.e., DVD, VCR/PVR or CBL/SAT. Then follow the directions in Step 4, below.
 - d) **HDMI 2 Source:** Press and release the Input Selector once, then quickly press the Input Selector again so that it turns green. Hold it until the Program LED starts to flash, then release it. Next, press the Input Selector that corresponds to the device type you want to program into the HDMI 2 mode, i.e., DVD, VCR/PVR or CBL/SAT. Then follow the directions in Step 4, below.

INSTALLATION



Figure 36 – Input Selectors

4. Enter a code from Step 1, above.
 - a) If the device turns off, then press the Input Selector again to accept the code; it will flash. The remote will exit the Program mode.
 - b) If the device does not turn off, try entering another code. If you run out of codes, you may search through all of the codes in the remote's library for that product type by pressing the ▲ or ▼ Button repeatedly until the device turns off. When the device turns off, enter the code by pressing the Input Selector, which will flash. The remote then exits Program mode.
5. Once you have programmed a code, it's a good idea to try using some other functions to control the device. Sometimes, manufacturers use the same Power code for several different models, while other codes will vary. You may wish to repeat this process until you've programmed a satisfactory code set that operates most of the functions you frequently use.
6. You may find out which code number you have programmed by pressing and holding the Input Selector to enter the Program mode. Then press the Set Button, and the LED will flash in the code sequence. One flash represents "1", two flashes for "2", and so forth. A series of many fast flashes represents "0". Record the codes programmed for each device in Table 3.

Table 3 – Remote Control Codes

Source Input	Product Type (circle one)	Remote Control Code
Video 1	VCR, PVR	
Video 2	Cable, Satellite	
Video 3	TV	
Video 4	TV	
HDMI 1	DVD, PVR, CBL, SAT	
HDMI 2	DVD, PVR, CBL, SAT	
DVD	DVD	
CD	CD, CDR	

After you have programmed a code set to operate a device, test the functions to see which ones may be missing or not operating correctly. You may "learn" individual key codes if you have the device's original remote control by following this procedure:

- a) Place the two remotes so that their IR transmitters face each other end to end, separated by about one inch. See Figure 37. The AVR 347 remote's transmitter also serves as an IR receiver during the learning process.

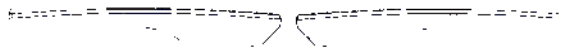

Figure 37 – AVR 347 and Original Remote Head-to-Head

- b) Press the Input Selector for the device mode you wish to learn a code into, and place the AVR 347 remote in Learning mode by pressing and holding the Learn Button until the Program Indicator flashes in amber, then release. See Figure 38.



Figure 38 – Learning Remote Commands

- c) Press the button on the AVR 347 remote you wish to program with the new code, and the Program Indicator will light steadily in amber.
- d) Press and hold the button on the device's original remote whose code you wish to "learn" until the Program Indicator flashes in green, then release it.
- e) You may program additional buttons by repeating steps c) and d).

Press the Learn button once to exit Learning mode. If you prefer, you may wait for the remote to "time out" and exit Learning mode on its own, but this will take about 30 seconds.

If you are unable to locate a code set that correctly operates your source device, it will not be possible to use the AVR remote to control that device. However, you may still connect the source to the AVR 347 and operate it using the device's original remote control. Alternatively, you may wish to consider purchasing Harman Kardon's optional TC 30 activity-based remote, which is programmed by accessing a large database of product codes on the Internet. The TC 30 is also capable of "learning" codes from your device's original remote.

Most of the button labels on the remote describe the button's function when used to control the AVR 347. However, the button may perform a very different function when used to control another device. Refer to the Remote Control Function List, Table A8 in the Appendix, for a list of each button's functions with the various product types.

If you wish, you may program Macros, which are preprogrammed code sequences that execute many code commands with a single button press. You may also program "punch-through" codes, which allow the remote to operate the volume, channel or transport controls of another device without having to switch the remote's device mode. See pages 60–61 for instructions on these advanced programming functions.

INSTALLATION

NOTE: The AVR 347 remote is preprogrammed to operate the transport controls of Harman Kardon DVD players when the AVR, the Video 2 (cable/satellite) or the Video 3 (TV) source is selected. You may change this punch-through programming at any time.

Step Nine – Remote IR Inputs and Output (Optional)

The AVR 347 is equipped with a Remote IR Input, a Multiroom IR Input and both full-carrier and stripped Remote IR Outputs to facilitate use of your system with a remote control in a variety of situations. See Figure 39.



Figure 39 – IR Inputs and Outputs

When the AVR 347 is placed in such a way that aiming the remote at the front-panel IR sensor is difficult, such as inside a cabinet or facing away from the listener, you may connect an external IR receiver, such as the optional Harman Kardon HE 1000, to the Remote IR Input jack. When you are using the AVR 347 in multiroom mode, you may connect an optional IR receiver, keypad or other control device to the Multiroom IR Input for remote control of the AVR 347 (and any sources connected to the AVR's Remote IR Output) from the remote zone. Any signals transmitted through the Multiroom IR Input will only control source selection and volume for the remote zone. If a source device is being shared with the main listening area, then any control commands issued to that source will also affect the main room.

If any of your source devices are equipped with a compatible Remote IR Input, you may use a 1/8" mini-plug interconnect cable (not included) to connect the AVR's Remote IR Output to the source device's Remote IR Input, which will pass any applicable remote signals transmitted through the AVR to the source device. This enables you to control your sources even when the AVR itself is controlled via an external IR receiver.

Check with the manufacturer of the source device for more information on the type of IR signal expected. The AVR 347 will output a "stripped carrier" IR signal through the Remote IR Output, but a full-carrier IR signal is available at the Carrier Remote IR Output.

To control more than one source device using the Remote IR Output, connect all sources in "daisy chain" fashion, with the AVR's Remote IR Output connected to the first device's Remote IR Input, that device's Remote IR Output connected to the next device's Remote IR Input, and so forth. Connect devices expecting a full-carrier IR signal to the Carrier Remote IR Output. Use the Remote IR Output for devices expecting a stripped signal.

Step Ten – Install a Multiroom System (Optional)

The AVR 347 offers several methods of distributing music to other listening areas in your home. As indicated in the subheading, installing a multiroom system is not required to enjoy the home theater experience. If you prefer not to install a multiroom system at this time, skip to Step Eleven to turn on the AVR 347 and configure it.

IMPORTANT SAFETY NOTE: Installing a multiroom system very often requires running various cables inside walls. Always comply with the appropriate safety codes when installing concealed wiring. The AVR 347's multiroom connections should be installed per the requirements of all applicable state and local building codes, as well as NEC (National Electrical Code) requirements. Check with your local authorities as needed to ensure that all wiring inside walls is installed in compliance with the proper standards. Failure to do so may present a potential safety hazard. If you have any doubt about your ability to work with electrical and telecommunications wiring, you are advised to hire a professional licensed electrician or custom installer to install the multiroom system.

1. Connect an external amplifier to the Multiroom Audio Outputs. See Figure 40.



Figure 40 – Multiroom Audio Outputs

It is recommended that you place the amplifier in the same room as the AVR 347 so that a shorter length of interconnect cable is used with a long run of speaker wire to the remote room, rather than placing the amplifier in the remote room, which necessitates a long run of interconnect cable that would be subject to signal degradation. Depending on the number of channels available in your amplifier, you may distribute the AVR 347's analog audio signal to a single pair of speakers for 2-channel listening, to several pairs of speakers located in several different rooms, or when listening to mono FM radio, to individual speakers placed in different rooms. (Use the Tuning Mode Button to select the mono mode for FM radio.)

The advantage of using the Multiroom Audio Outputs is the ability to have a 7.1-channel system in the main listening area at the same time others are listening to a different source in the remote zone. However, the benefit is achieved at the expense of purchasing an additional component, i.e., the amplifier.

2. Connect the remote speakers directly to the Surround Back/Multiroom Speaker Outputs. See Figure 41.



Figure 41 – Surround Back/Multiroom Speaker Outputs

If you do not require a full 7.1-channel system in your main listening area, and you prefer not to purchase an external amplifier to power a pair of remote speakers, you may reassign the AVR 347's surround back amplifier channels to power the speakers. Your main system will be limited to 5.1 channels, which affects your ability to enjoy the many DVDs and other programs recorded in 6.1 and 7.1 channels.

INSTALLATION

3. Connect an external amplifier to the Surround Back/Multiroom Preamp Outputs. See Figure 42.



Figure 42 – Surround Back/Multiroom Preamp Outputs

This method may be used when it is more important to distribute audio to additional rooms than to have a full 7.1-channel system in the main listening area, as it is still necessary to assign the surround back amplifier channels to the remote zone, limiting the main system to 5.1 channels. This method also requires you to provide an additional component, that is, the amplifier. However, this method may be used to increase the number of remote rooms in the system when you are also using the other options for connecting a multiroom system.

4. Connect an A-BUS hub or other A-BUS components to the A-BUS Port. See Figure 43.



Figure 43 – A-BUS Port

Use Category 5/5e cable as described in the instructions for your A-BUS components. The A-BUS system may carry the audio signal to the remote components, while receiving IR control codes, depending on the capabilities of your A-BUS components. If you connect a hub to the AVR 347, you may distribute audio to many remote rooms. Visit our Web site at www.harmankardon.com for information on our available hubs, the ABH 4 and ABH 4000, and amplified in-wall modules, the AB 1 and AB 2.

In addition to the audio signal, you will usually wish to connect an IR control device to the AVR 347's Multiroom IR Input so that listeners in the remote room may turn the multiroom system on or off, select a source input, control the source device connected to that input and adjust the volume in the remote zone. As mentioned above, an A-BUS system does not require a separate IR control connection.

By using external multichannel amplifiers and A-BUS hubs, it's possible to construct a system that distributes audio to many rooms throughout your home.

NOTE: Only analog audio sources are available to the multiroom system.

Step Eleven – Turn On the AVR 347

Two steps are required the first time you turn on the AVR 347.

1. Gently press the Master Power Switch until the word OFF is no longer visible. The Power Indicator above the two power switches should light up in amber, indicating that the AVR is in Standby mode and is ready to be turned on. See Figure 44. Normally, you may leave the Master Power Switch in the ON position, even when the receiver is not being used.



Figure 44 – Power Switches

2. There are several ways in which the AVR 347 may be turned on from Standby mode.

- a) Press the Standby/On Switch on the front panel. See Figure 44.
- b) Press the Source Select Button on the front panel. See Figure 45.



Figure 45 – Source Select Button

- c) Using the remote, press any one of these buttons: AVR, DVD/CD, TAPE/The Bridge, HDMI 1/2, VID1, VID2, VID3, VID4, XM, AM/FM or 6/8CH. See Figure 46.



Figure 46 – AVR and Input Selectors

NOTE: Any time you press one of the Input Selectors on the remote (i.e., DVD/CD, TAPE/The Bridge, HDMI 1/HDMI 2, VID1, VID2, VID3 or VID4), the remote will switch modes so that it will only transmit the codes programmed to operate that device. In order to control the receiver, press the AVR button to return the remote to AVR mode.

INITIAL SETUP

Before you begin enjoying your new receiver, a few adjustments should be made to configure the AVR 347 to match your actual system.

Make sure that you have connected a video display to one of the video monitor outputs on the receiver. When you turn on your display and the AVR, you should see a blue screen. A message may appear briefly at the bottom of the screen. This message is part of the on-screen display system, and is referred to as the "semi-OSD". The semi-OSD is activated any time you send a command to the AVR, and any time the AVR detects a change in the incoming signal. Semi-OSD messages are overlaid on top of any video signal, so that you may continue to watch your program while making adjustments to the AVR.

Although it's possible to configure the AVR using only the remote and the semi-OSD messages, we recommend that you use the full-screen menu system, known as the "full OSD".

Using the On-Screen Menu System

The full-OSD system is accessed by pressing the OSD Button on the remote. See Figure 47. While the full-OSD system is in use, it isn't possible to see any video programming. In addition, an OSD ON message will appear on the front panel of the receiver to remind you to use a video display.



Figure 47 – Navigation Buttons

NOTE: The ◀/▶ and Set Buttons on the front panel have no effect on the OSD system.

The OSD system consists of six main menus: Input Setup, Surround Setup, Speaker Setup, Multiroom Setup, Video Setup and System Setup. Navigation tabs for each menu appear on the left side of the screen. When you first press the OSD Button, the Input Setup menu will be visible (see Figure 48), since its tab is at the top of the screen. However, you must press the Set Button to select the Input Setup menu so that you can make any necessary adjustments. If you wish to select another menu, use the ▲/▼ Buttons to highlight the tab for the desired menu, and press the Set Button to select it.

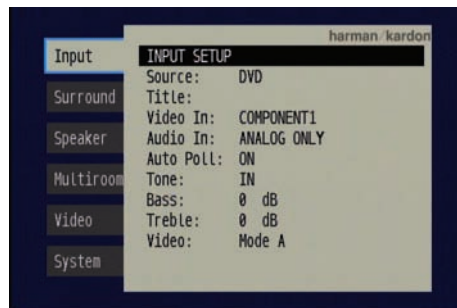

Figure 48 – OSD System

When you first select a menu, the first setting line will be highlighted (see Figure 49).

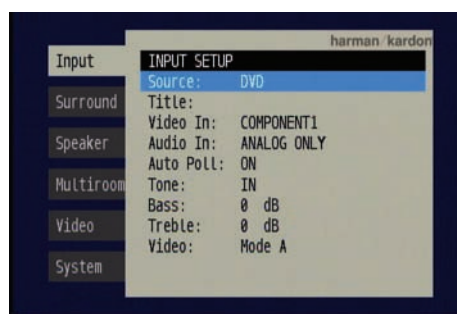

Figure 49 – Input Setup Menu

If you wish to change that setting, press the Set Button. Although the setting name will remain highlighted, the value will appear in blue type with arrows to the left and right, indicating that you may use the ◀/▶ Buttons to scroll through the available values. See Figure 50. When the desired value appears, press the Set Button to select it.

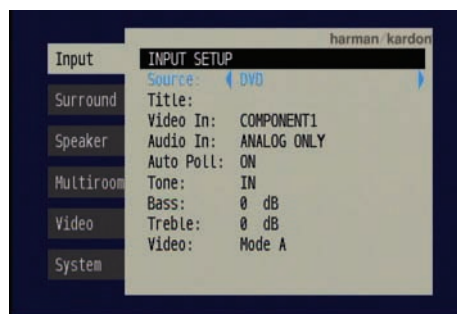

Figure 50 – Changing a Setting

Use the ▲/▼ Buttons to navigate to other settings within the menu. When you have finished making all adjustments in that menu, press the ◀ Button to return to the navigation tabs, and then use the ▲/▼ Buttons to select the tab for another menu.

We recommend that most users follow the instructions in this INITIAL SETUP section to configure a basic home theater system. You may return to these menus at any time to make additional adjustments. Thanks to the EzSet/EQ system, most of the menu adjustments may be saved until you have become more familiar with the AVR, and are therefore described in the Advanced Functions section.

INITIAL SETUP

The Initial Setup section requires that you complete all of the steps in the Installation section that apply to your receiver. You should have connected all of your loudspeakers and a video display, as well as your source devices. You should be able to turn on the receiver and view a blue screen on your video display. If necessary, reread the Installation Section before continuing.

Configure the AVR 347 Using EzSet/EQ

One of the most important and perhaps often overlooked aspects of setting up a home theater system is to calibrate the receiver to match the loudspeakers, which enables the AVR to perform at its best.

Until recently, most receivers required the user to perform the calibration and configuration manually, a somewhat tedious process that called for a good ear or the purchase of an SPL (sound-pressure level) meter. Although you may configure the AVR 347 manually, as described in the Advanced Features section, we recommend that most users take advantage of our signature EzSet/EQ system.

Before beginning, eliminate extraneous background noise that might affect the results, such as noisy air conditioning. Try to avoid making any loud noises while running EzSet/EQ.

IMPORTANT SAFETY NOTE: During the EzSet/EQ procedure, a series of very loud test tones will be played through all of the speakers. Avoid sitting or standing close to any one speaker during the procedure. If you are particularly sensitive to loud noises, you may wish to leave the room and have someone else run EzSet/EQ.

Step One – Place the included EzSet/EQ microphone in the listening position, or in the center of the room, at about the same height as the listeners' ears. The microphone features a threaded insert on the bottom so that it can be mounted on a camera tripod for stability. An extender rod is also included.

Step Two – Plug the EzSet/EQ microphone into the Headphone Jack/EzSet Microphone Input Jack on the front of the receiver. See Figure 51.



Figure 51 – Plug EzSet/EQ microphone into receiver.

Step Three – Make sure that the AVR 347 and the video display are turned on. Press the OSD Button to display the Menu System. See Figure 48. Use the ▲/▼ Buttons to move the cursor to the Speaker Setup tab, and then press the Set Button to select the Speaker Setup menu. See Figure 52.

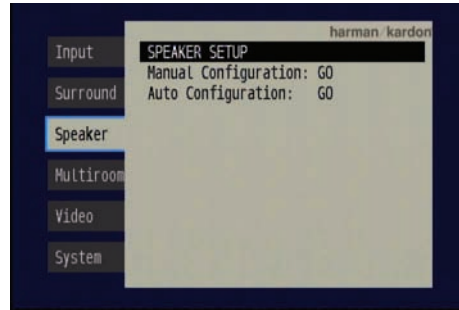

Figure 52 – Speaker Setup Menu Screen

Select the “Auto Configuration” setting, and the screen shown in Figure 53 will appear to direct you to plug the EzSet/EQ microphone into the Headphone Jack.

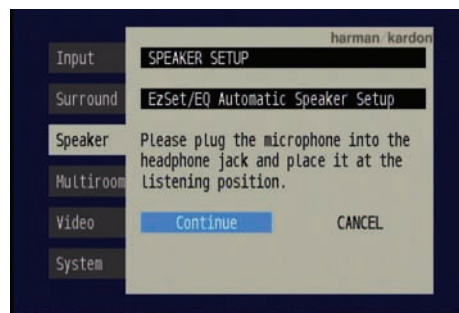

Figure 53 – EzSet/EQ Screen

Step Four – After you select “Continue”, the screen shown in Figure 54 will appear. Although the AVR 347 may be used with up to eight speakers, you may have elected not to install surround back speakers at this time, or you may have decided to use the surround back speaker channels to power speakers in the remote room of a multiroom system. This screen directs you to program EzSet/EQ for a 5.1- or 7.1-channel configuration. Select the setting that reflects the number of speakers installed in your system, and EzSet/EQ will do the rest automatically!

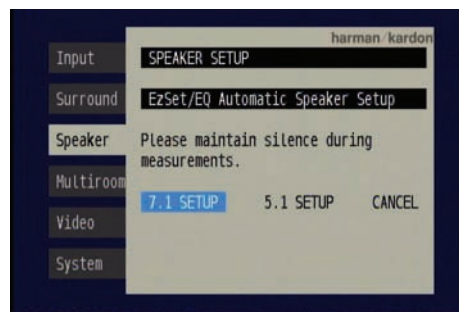

Figure 54 – EzSet/EQ: Number of Speakers

NOTE: If you are using fewer than five main speakers in your system, then it will not be possible to configure your speakers using EzSet/EQ, and you will need to select Manual Configuration as described in the Advanced Functions section. If you have selected a 6.1-channel configuration, using only a single surround back speaker, it is possible to use a combination of EzSet/EQ automatic configuration for 5.1 speakers, connect the single

INITIAL SETUP

surround back speaker to the left Surround Back Speaker Output, and then configure the surround back speaker manually, as described in the Advanced Functions section. However, we do not recommend the 6.1-channel configuration.

If you have forgotten to plug in the EzSet/EQ microphone, the warning screen shown in Figure 55 will appear as a reminder.

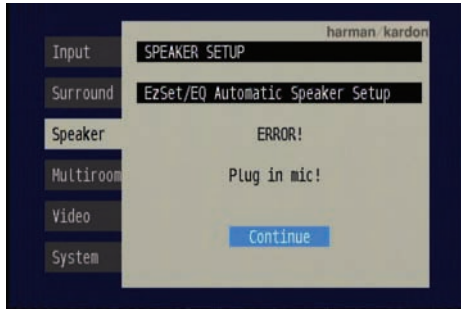

Figure 55 – EzSet/EQ: Warning to Plug in Microphone

NOTE: As shown in Figures 53, 54 and 56–59, while EzSet/EQ is in progress a Cancel setting is highlighted. You may interrupt EzSet/EQ at any time by simply pressing the Set Button.

What EzSet/EQ Does

EzSet/EQ will send test signals to the various speakers and perform the measurements described in this section, adjusting the AVR 347's settings to match EzSet/EQ's internal references.

Set Master Volume Level: EzSet/EQ sends test tones to the front speakers and adjusts the system's volume level to enable it to take the remaining measurements correctly. EzSet/EQ uses the left front speaker to set the master volume level, and then it proceeds directly to measuring the speaker output levels.

Speaker Level: During this test, EzSet/EQ ensures that all speakers sound equally loud at the listening position. During a surround sound presentation it is common for the surround channels to sound less prominent, or not to be used at all at times. By setting the baseline channel levels correctly, the AVR behaves as a blank canvas for the movie director to create special effects.

A screen similar to the one shown in Figure 56 will appear, with the speaker position changing as EzSet/EQ measures the levels for each speaker. You may occasionally hear EzSet/EQ send a tone back to the front left speaker. This enables EzSet/EQ to compare the level of the speaker being measured to the reference level it set for the front left speaker.

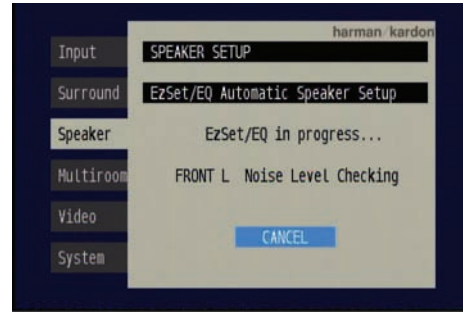

Figure 56 – EzSet/EQ: Speaker Level Test

If at any time the test tone is not heard from the speaker indicated on screen, press the Set Button to stop EzSet/EQ. Turn off the AVR using the Master Power Switch and check your speaker connections. Make sure all wires are connected to the correct speakers and Speaker Outputs on the AVR, and that you have observed the correct polarity (+ terminals connected to + terminals, and – terminals connected to – terminals).

NOTE: EzSet/EQ can detect only the presence of a speaker, not its location within the room. If your speakers are not placed reasonably close to the positions shown in the Speaker Placement Section on page 23, EzSet/EQ may not be able to perform this test correctly.

If EzSet/EQ detects only one speaker in a pair (e.g., surround back left but no surround back right or no main speakers), it will generate an error and stop. If that happens, check that you have placed your speakers in their correct locations, and that you have wired each speaker to its correct set of speaker terminals.

Speaker Distance: During this test, EzSet/EQ measures the distance from each speaker to the listening position. If the speakers are placed at different distances from the listener, the sound from speakers placed closer needs to be delayed so that it reaches the listener at the same time as the sounds from the other speakers. This preserves the clarity and directionality of surround sound presentations. During the Speaker Distance test a screen similar to the one shown in Figure 57 will appear. The speaker position will change as EzSet/EQ measures the distance for each speaker.

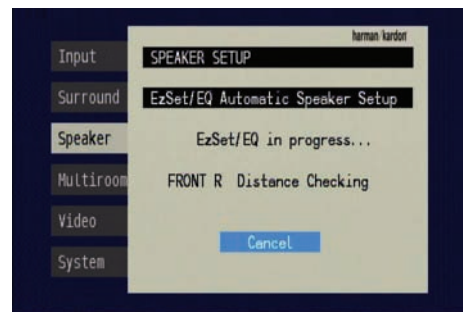

Figure 57 – EzSet/EQ: Speaker Distance Test

NOTE: The AVR 347 is also capable of setting a different type of delay, called A/V Sync Delay. A/V Sync Delay is used to compensate for lip sync problems that may occur when a video

INITIAL SETUP

display device or set-top box causes delays while digital video signals are processed. It simultaneously adds a delay to all speaker channels in the system. A/V Sync Delay is not set during EzSet/EQ. It may be set while watching a program as follows: press the Delay Button on the remote and the first setting displayed is A/V Sync Delay. Press the Set Button to select it and then use the ▲/▼ Buttons to adjust it.

Speaker Size: This test checks the low-frequency range capabilities of each of your speakers to ensure that low-frequency sounds are not sent to speakers unable to reproduce them efficiently. Each of the main speakers in your system will be assigned a value of Large or Small, depending solely on how it handles low frequencies. During the Speaker Size test a screen similar to the one shown in Figure 58 will appear, with the speaker position changing as each speaker is measured.

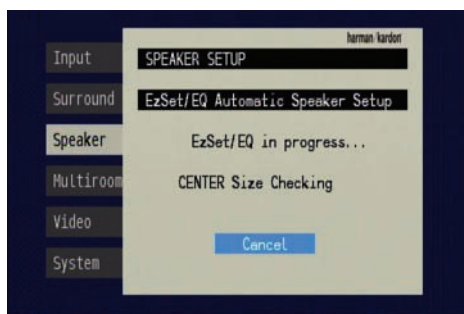

Figure 58 – EzSet/EQ: Speaker Size/Crossover Test

At the same time the overall size of the speaker's frequency range is measured, the AVR will measure the crossover, which is the lowest frequency each of your main speakers is capable of handling effectively, in order to set the highest frequency the subwoofer should reproduce. The system balances the need to ensure that all frequencies are reproduced for smooth transitions between the subwoofer and main speakers without losing any information, against the need to avoid overtaxing smaller satellite speakers.

NOTE: The crossover determined by EzSet/EQ is not the same as the crossover frequency specification that appears in the speaker's manual. EzSet/EQ is measuring the point at which the audio signal must be passed from the main speaker to the subwoofer. For an individual loudspeaker, the manufacturer specifies the point or points at which the audio signal is passed from one transducer within the speaker to another.

Equalization (EQ): Many factors unique to the listening room can affect the overall sound of a home theater system. For example, a room consisting of hardwood floors and large expanses of glass can sound livelier, with added reverberation, while a carpeted room fitted with draperies can dampen sound waves. In addition, the shape of the room can affect frequency response. If a room has a small alcove near a doorway, for example, you may notice a difference in bass response depending on whether you are standing opposite the alcove or to one side of it.

EzSet/EQ is capable of measuring the impact room characteristics and speaker placement have on each speaker's performance, and of making adjustments to low-frequency response to compensate. While EzSet/EQ

is making these adjustments a screen similar to the one shown in Figure 59 will appear. You may hear EzSet/EQ repeat tones from various speakers a number of times as it performs the equalization.

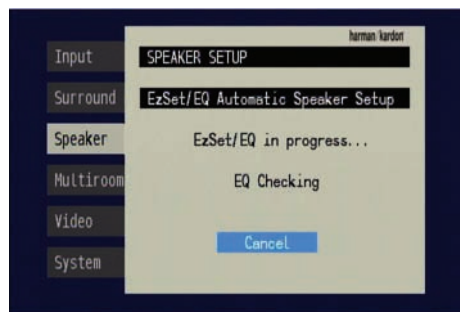

Figure 59 – EzSet/EQ: Equalization

When EzSet/EQ has finished running all of these tests, a screen similar to the one in Figure 60 will appear. You may press the Set Button, and the Speaker Setup screen shown in Figure 52 will appear. Select "Manual Configuration" to view the settings resulting from EzSet/EQ. The manual Speaker Setup screens are explained in the Advanced Functions section.

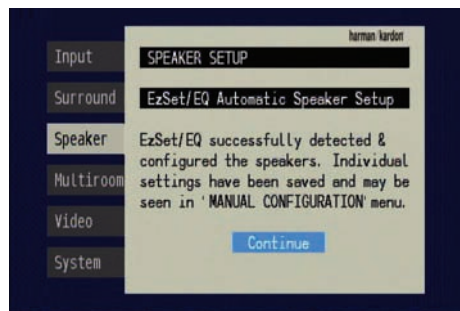

Figure 60 – EzSet/EQ: Successful Configuration

Configure Sources

In the Installation section, you physically connected various cables between your source devices and the AVR. In this section, you will assign the various audio and video inputs to their sources, ensuring that the AVR uses the correct connections each time you select a source.

Press the OSD Button to view the menu system. The Input Setup menu tab will be highlighted. Press the Set Button to select it, and the screen shown in Figure 61 will appear.

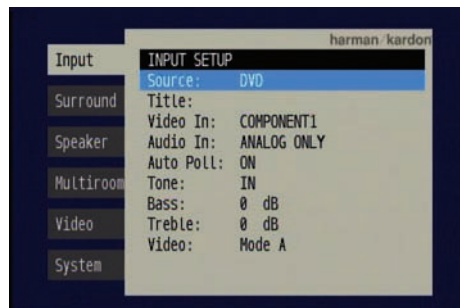

Figure 61 – Input Setup Menu

INITIAL SETUP

The first line indicates that the receiver is currently set to the DVD source.

Press the Set Button, and then use the ► to view the next source. The sources will be selected in the following order: Video 1, Video 2, Video 3, Video 4, HDMI 1, HDMI 2, 6CH Direct, 8CH Direct, DMP/The Bridge, Tape, CD, TUNER and XM. Pressing the ◀ Button selects the sources in the reverse order.

For each of these sources, you may adjust the following settings. At a minimum, you should make sure that sources connected to any of the component video or digital audio inputs have the correct settings. Other settings are optional, and you may adjust them at a later time when you have more experience with the AVR. Refer to the Table A4 worksheet in the appendix that you filled out during installation as you assign inputs to each source.

TITLE: You may change the display name for any source. Not only does this enable you to customize your system; it helps you to select the correct source device even when you have forgotten which physical connections were used.

Move the cursor down to the TITLE line and press the Set Button. The screen shown in Figure 62 will appear.



Figure 62 – Retitling a Source Input

Use the Navigation Buttons to highlight the desired letter (or other character), and press the Set Button to add it to the new title, which will be displayed in the bar at the top of the screen. You may use the Navigation Buttons, or select the left or right arrow and press the Set Button, to move the cursor within the new title. To add a space either move the cursor one character to the right as described above, or highlight the SPACE indicator on screen and press the Set Button.

You may edit a title by inserting or deleting characters. To insert a new character between two existing characters, move the cursor to highlight the character to the right of the insertion point in the bar at the top of the screen. Then highlight the INS indicator on screen and press the Set Button. You may now select a character to insert in the new space. Delete a character by moving the cursor to highlight the unwanted character in the bar at the top of the screen. Then highlight the DEL indicator on screen and press the Set Button.

When you have finished entering the new title, highlight the OK indicator and press the Set Button to return to the Input Setup menu. Although the Source Input name will remain the same in the Input Setup menu, the new title will appear in the semi-OSD displays and the front-panel display as appropriate.

NOTES:

- Only upper case letters are available for titles.
- Normally both the source input and the digital (or analog) audio input selection appear on the upper line of the semi-OSD and front-panel displays. When The Bridge source is selected, its status as CONNECTED or UNPLUGGED appears in place of the audio input selection. However, when a source input is retitled, the audio input selection (or status of The Bridge) no longer appears unless you press the Digital Input Selector on the remote or front panel.

VIDEO IN: This setting reflects the video input that is assigned to the source. The default assignment for all sources is COMPOSITE except as shown in Table 5:

Table 5 – Default Video Inputs

Source Input	Default Video Input
DVD	Component 1
Video 1	Component 2
Video 2	Component 3
HDMI 1	HDMI 1
HDMI 2	HDMI 2

We recommend that you leave the setting for the HDMI sources as is. For the other sources, change this setting to reflect use of the Component 1, 2 or 3 Video Input as appropriate. If you used the composite or S-video input for any source, make sure this setting is COMPOSITE. (There is no separate selection for S-video.)

NOTE: If your video display has an HDMI input, then you only need to connect the AVR's HDMI Output to the display. The AVR 347 transcodes analog source video signals up to 720p from composite, S-video or component video to the HDMI format, and is also capable of upscaling the signal up to 720p to match your display's capabilities. The only exception to this rule is for analog 1080i/p sources, which are not available at the HDMI Output, and are downconverted to 720p for the Component Video Outputs. If your source device is a Microsoft Xbox 360 or an older set-top box that outputs 1080i or higher video via component video outputs, then set the source to output 720p video, or connect its component video outputs to your video display.

If your display does not have an HDMI input, but does have component video inputs, you only need to connect the AVR's Component Video Monitor Outputs to the display. The AVR 347 transcodes composite and S-video signals to the component video format. Similarly, if your display's best-quality video input is S-video, you do not need to connect the Composite Video Monitor Output to the display; any composite video source signals will be converted to S-video format, and S-video signals may be converted to composite video format if your video display is not equipped with an S-video input.

INITIAL SETUP

AUDIO IN: By default, the analog audio inputs are assigned at the factory to all sources, with the following exceptions:

Table 6 – Default Digital Audio Assignments

Source Input	Default Digital Audio Input
DVD	Coax 1
Video 2	Optical 1
HDMI 1	HDMI 1
HDMI 2	HDMI 2

If you used a digital audio connection for another source, change this setting to assign the correct digital audio input to the source, even if you also connected the analog audio outputs of the source to the receiver.

AUTO POLL: The Auto Poll feature is used when both an analog audio and digital audio connection have been made for one source device. If for some reason no digital signal is available, the AVR 347 will switch to the analog inputs for the source. This situation can occur with some cable or satellite television broadcasts, where some channels are broadcast with digital audio and others with analog audio.

For some sources, the Auto Poll feature is unnecessary and may be undesirable. For example, if your DVD player is stopped, you may not want to use the analog audio signal or you may have decided not to connect analog audio. Move the cursor to this line, press the Set Button, and press the ◀/▶ Buttons until OFF appears, disabling the Auto Poll feature. With Auto Poll turned off, the receiver will only check for a signal at the audio input assigned to the source.

NOTE: Since The Bridge is connected to the AVR using a dedicated audio connection, it isn't possible to select a different audio input for this source. The AM/FM/XM tuner and 6-/8-Channel Inputs also use dedicated audio inputs, and it isn't possible to select a digital audio input for these sources.

The next three lines in the Input Setup menu activate the tone controls, and may be skipped at this time. We recommend leaving the tone controls at their factory defaults for most listening, in order to enjoy the sound mix created by your favorite movie and music artists. However, if your room or speakers have unusual characteristics, or simply as a matter of personal preference, see the Tone Controls section on page 40 for more information.

VIDEO MODE: This setting is used only with a fully analog video path (composite, S-video or component video). It has no effect on HDMI sources and video displays. Due to the design of some analog video displays and the nature of the video standard, there may be timing issues with the AVR. If you observe some minor video instability when using the AVR's analog video outputs, try changing the Video Mode setting to Mode B. If you continue to observe problems, connect your source device's video output directly to the video display, or consider upgrading to an HDMI-capable display.

You are now ready to begin enjoying your new receiver!

OPERATION

Now that you have installed your system components and completed at least a basic configuration of your receiver, you are ready to begin enjoying your home theater system.

Turning On the AVR 347

Gently press the Master Power Switch until the word OFF is no longer visible. The Power Indicator above the two power switches should light up in amber. This indicates that the AVR is in Standby mode and is ready to be turned on. Normally, you may leave the Master Power Switch in the ON position, even when the receiver is not being used. See Figure 63.



Figure 63 – Power Switches

There are several ways in which the AVR 347 may be turned on:

- Press the Standby/On Switch on the front panel. See Figure 63.
- Press the Source Select Button on the front panel. See Figure 64.



Figure 64 – Source Select Button

- Using the remote, press any one of these buttons: AVR, DVD/CD, TAPE/The Bridge, HDMI 1/HDMI 2, VID1, VID2, VID3, VID4, XM, AM/FM, 6/8CH. See Figure 65.



Figure 65 – AVR and Input Selectors

NOTE: Any time you press one of the remote's Input Selectors (i.e., DVD/CD, TAPE/The Bridge, XM, VID1, VID2, VID3, VID4 or HDMI 1/HDMI 2), the remote will switch modes so that it will only operate that device. To control the receiver, press the AVR Button to return the remote to AVR mode.

To turn the receiver off, press either the Standby/On Switch on the front panel, or press the AVR Button and the OFF Button on the remote. Unless the receiver will not be used for an extended period of time (for example, if you will be on vacation), it is not necessary to turn off the Master Power Switch. When the Master Power Switch is turned off, any

settings you have programmed, including system configuration and preset radio stations, will be preserved for up to four weeks.

Sleep Timer

You may program the AVR to play for up to 90 minutes and then turn off automatically using the sleep timer.

Press the Sleep Button on the remote, and the time until turn-off will be displayed. See Figure 66. Each additional press of the Sleep Button will reduce the time until turn-off by 10 minutes, until the OFF setting is reached, which disables the sleep timer.



Figure 66 – Sleep Button

When the sleep timer has been set, the front-panel display will automatically dim to half-brightness. If you press any button on the remote or front panel, the display will return to full-brightness. The display will dim again several seconds after your last command.

If you press the Sleep Button after the timer has been set, the remaining time until turn-off will be displayed. You may press the Sleep Button to change the time until turn-off. Pressing and holding the Sleep Button will disable the sleep timer, and the SLEEP OFF message will appear.

Volume Control

The volume may be adjusted either by turning the knob on the front panel (clockwise to increase volume or counterclockwise to decrease volume), or by pressing the Volume Control Buttons on the remote. See Figure 67. The volume is displayed as a negative number of decibels (dB) below the 0dB reference point, and may be changed in 0.5dB increments.

Unlike the volume controls on some other products, 0dB is the maximum volume for the AVR 347. Although it's physically possible to turn the volume to a higher level, doing so may damage your hearing and your speakers. For certain more dynamic audio materials, even 0dB may be too high, allowing for damage to equipment.



Figure 67 – Volume Controls

The AVR 347 is designed to reproduce audio with a minimum amount of distortion, which may lead you to think that your hearing and the equipment can handle higher volumes. We urge caution with regard to volume levels.

OPERATION

Mute Function

To temporarily mute all speakers and the headphones, press the Mute Button on the remote. See Figure 68. Any recording in progress will not be affected. The MUTE message will flash in the display as a reminder. To restore normal audio, either press the Mute Button again, or adjust the volume. Turning off the AVR will also end muting.



Figure 68 – Mute Button

Tone Controls

You may boost or cut either the treble or the bass frequencies by up to 10dB.

Using the front-panel controls or the remote, press the Tone Mode Button once. See Figure 69. This will indicate whether the tone controls are in or out of the circuitry. If you wish to return the tone controls to 0, or "flat" response, press the ◀/▶ Buttons (▲/▼ on the remote) until the TONE OUT message appears, which preserves any changes you have made to the bass or treble settings for later use. To reactivate your changes, the tone control must again be set to TONE IN.

With the TONE IN message displayed, press the Tone Mode Button repeatedly to access TREBLE MODE and BASS MODE. Use the ◀/▶ Buttons (▲/▼ on the remote) to change the treble or bass settings, as desired. The display will return to normal a few seconds after your last command.



Figure 69 – Tone Button

You may alternatively adjust the tone controls using the full-OSD menu system. Press the OSD Button on the remote to view the Menu System. The Input Setup tab will be highlighted. Press the Set Button to activate the Input Setup menu. If you wish to make any changes to the TONE, BASS or TREBLE settings, use the ▲/▼ keys on the remote to move the cursor to the line you wish to change and press the Set Button. Once you have changed the setting using the ◀/▶ Buttons, press the Set Button to enter the new setting. When you have finished, either wait until the display times out and disappears, press the OSD Button to clear the display, or move the cursor to the menu tabs on the left side of the screen, if you wish to make other changes using the menu system.

NOTE: The AVR 347 does not have a conventional balance control. The EzSet/EQ process compensates for any characteristics of your room or speakers, and we recommend that you leave the settings as they are after EzSet/EQ has been run. However, you may manually adjust the levels of the left and right channels – decreasing one and increasing the other by the same amount – using the Channel Adjust submenu, as described in the Advanced Functions section. This achieves the same effect as a balance control.

Headphones

Plug the 1/4" plug on a pair of headphones into the headphone jack on the front of the receiver for private listening. See Figure 70. The first time you use the headphones, the DOLBY H:BP message will be displayed, indicating that Dolby Headphone surround processing is in the bypass mode, which delivers a conventional 2-channel signal to the headphones.



Figure 70 – Headphone Jack

Press the Surround Select Button on the front panel, or the Dolby Button on the remote, to switch to Dolby Headphone virtual surround processing, indicated by the DOLBY H:DH message. Dolby Headphone delivers an enhanced sound field that emulates a 5.1-channel speaker system. No other surround modes are available for the headphones.

Source Selection

Press the front-panel Source Select Button to scroll through the sources. The left side of the button scrolls down the list that appears in the display; the right side scrolls upward. For direct access to the tuner, press the Tuner Band Button, which switches to the last-used band and frequency. See Figure 71.



Figure 71 – Source Select and Tuner Band Buttons

NOTE: The Bridge/DMP, HDMI 1 and HDMI 2 sources have no icon in the Source Indicators display. When selected, the appropriate indication will appear in the Message Display's upper line. One of two messages will scroll on the right side to indicate whether The Bridge is unplugged or connected. If you have retitled this source, then only the new name will appear in the upper line.

For direct access to any source, press its Input Selector on the remote (see Figure 65). Since the AVR 347 allows for more source input devices than the remote has buttons for, some sources are required to share buttons. These are the DVD and CD sources, the Tape and The Bridge sources, and the HDMI 1 and HDMI 2 sources. The first press

OPERATION

of any of these three Input Selectors will select the source whose name appears on the button (i.e., DVD, Tape or HDMI 1), as indicated by the button lighting up in red. Press that Input Selector again quickly to select the source whose name appears above the button (i.e., CD, The Bridge or HDMI 2), and the selector will light in green to indicate that you have selected the source whose name is printed above the button.

The AVR 347 will switch to the audio and video inputs assigned to the source. If you selected a surround mode for the source, the AVR 347 will switch to that mode.

The source name will appear in the upper line of the front-panel display. If you retitled the source, only the new title will appear. Otherwise, the audio input assigned to the source (analog or one of the digital audio inputs) will also appear. The surround mode will be displayed on the lower line. The same information will also appear on screen in the semi-OSD, unless you have set the semi-OSD to OFF in the System Setup menu, as described in the Advanced Functions section.

Audio Input Selection

The AVR 347 is programmed at the factory to use the analog audio inputs for each source (except for the DVD, Video 2, HDMI 1 and HDMI 2 sources; see Table 4). To assign a digital audio input to a source (if you have not done so using the Input Setup menu during Initial Setup), press the Digital Button on the remote or front panel. The current audio input selection will flash in the display, and you may press the ▲/▼ (or ◀/▶ on the front panel) Buttons to scroll through the audio inputs. When the desired input appears, press the Set Button to select it. See Figure 72.



Figure 72 – Digital Input Selection

If the Auto Poll feature is ON in the Input Setup menu, and if a digital audio input has been assigned to the source, the AVR 347 will first check the digital audio input for a signal. If a signal is present, the AVR 347 will select the digital audio input. If no signal is present, the AVR 347 will switch to the analog audio inputs for the source.

Video Input Selection

When a source is selected, the AVR 347 switches to a video input as follows:

The VIDEO IN line of the Input Setup menu indicates which of the video inputs on the AVR 347 is assigned to each source. As shown in Table 5, by default the Component Video 1 input is assigned to the DVD source, the Component Video 2 input is assigned to the Video 1 source, and the Component Video 3 input is assigned to the Video 2 source. The two HDMI inputs obtain the video signal from their own inputs, and may not be reassigned to another video input.

If your iPod is capable of playing still images and videos, it may be used as a video source. However, you may reassign the video input for The Bridge to another device for viewing while listening to audio files stored on the iPod.

All other sources default to the COMPOSITE setting, meaning that they may only be used with their composite or S-video inputs. The AVR 347 will transcode the incoming composite or S-video signal and make it available using the HDMI or component video monitor outputs, enabling a single-cable connection to your television.

NOTES:

- Due to copy-protection restrictions, there is no output at the Component Video Monitor Outputs for copy-protected sources.
- High-resolution 1080i and 1080p video signals are not available at the HDMI Output, and are downconverted to 720p for the Component Video Monitor Outputs. If your source outputs analog high-resolution video, either use the Component Video Outputs, change the output resolution of your source device to 720p, or connect your source's component video outputs directly to your video display.
- Due to the design of some video displays, analog 480p or 720p component video source signals may produce artifacts when used with the AVR's analog video outputs (composite, S-video or component video). If this occurs, try changing the Video Mode setting in the INPUT SETUP menu, or connecting the source device's video output directly to your video display. However, for best results, we recommend you consider upgrading to an HDMI-capable video display.
- The AVR 347 cannot convert 1080i or 1080p analog video signals to the HDMI format and downconverts them to 720p for the Component Video Outputs. This affects users of Microsoft Xbox 360 systems and some older set-top boxes. If your digital cable television set-top box outputs 1080i or higher video via component video outputs and is not equipped with an HDMI output, contact your cable operator for a replacement. For Xbox 360 or satellite receivers with no HDMI output, change the settings on your source device so that it outputs only 720p video through its component video outputs, which the AVR can convert to the HDMI format. Although you could connect the source device's component video outputs directly to your video display, you would then have to select the correct video input on the display to match the AVR's input.

The component video inputs may be reassigned to other source inputs as needed, depending on the physical connections you made during the Installation procedure.

If a signal is present at the component video input assigned to that source, it will be selected.

If no signal is present at the component video input, then the S-video or composite video input for the source will be selected. It is not possible to reassign the S-video or composite video inputs to other sources.

For audio-only sources, such as the tuner or CD inputs, when no component video signal is present, the last-used video source will be selected.

OPERATION

6-/8-Channel Direct Inputs

If you wish to hear audio through the 6-/8-Channel Direct Inputs together with video, then connect your multichannel player to the Component Video 1 Inputs, and connect the player's 6- or 8-channel analog audio outputs to the 6-/8-Channel Inputs on the AVR. Assign the component video inputs you selected to the 6-/8-Channel Input source. The AVR will automatically select the correct component video and audio inputs when you select this source.

If you need to use composite or S-video for your multichannel player, e.g., if your video display does not have component video inputs, then connect the device to the video inputs for another source. Since the AVR automatically selects the last-used video inputs for audio sources, first select the source you connected the video cables to, and then the 6-/8-Channel Inputs for the audio.

Example 1: You would like to connect a DVD-Audio player to the AVR 347. You plan on playing a variety of discs using this player, including conventional DVDs and even CDs, as well as multichannel discs. When playing DVDs and CDs, it is preferable to use a digital audio connection to obtain the best sound quality and the benefit of any digital surround formats contained on the DVD. However, when playing DVD-Audio discs, you will need to use the 6-/8-channel analog audio connections. In addition, some of these discs contain video materials. The player does not have an HDMI output.

We recommend that you connect this player as follows:

- Connect the player's coaxial digital audio output to the Coaxial 1 input on the AVR. This input is assigned by default to the DVD source.
- Connect the player's component video outputs to the Component Video 1 inputs on the AVR, which are assigned by default to the DVD source. If your video display doesn't have component video inputs, then connect the player's composite or S-video output to the DVD's corresponding video input.
- Connect the player's 6-channel analog audio outputs to the AVR's 6-/8-Channel Inputs and assign the Component Video 1 inputs to this source using the Input Setup menu, as described in the Initial Setup section.
- Program the player's remote control codes into the DVD Input Selector. Note that not all commands will necessarily be available.

When you wish to view a DVD, simply select the DVD source.

When you wish to listen to a DVD-Audio disc and view the menus and other still images on the disc, first select DVD, and then the 6-/8-Channel Inputs as the source.

Example 2: In this example, your multichannel disc player is equipped with an HDMI output, but it does not comply with HDMI version 1.1. Connect it as follows:

- Connect the player's HDMI output to the HDMI 1 source input, and make sure to connect the AVR's HDMI Output to your video display. The player will transmit both digital audio (e.g., Dolby Digital or DTS

audio found on a DVD-Video disc) and video via the HDMI connection. It is not necessary to make a separate digital audio connection.

- Connect the player's 6-channel analog audio outputs to the AVR's 6-/8-Channel Inputs and connect one of the player's analog video outputs to a source input on the AVR (e.g., Component Video 3 or Video 3).
- Program the player's remote control codes into the Input Selector corresponding to the source you used for the analog video connection, e.g., Video 3.

When you wish to view a DVD, simply select the HDMI 1 source.

When you wish to play a multichannel disc, first select the analog video source, e.g., Video 3, to obtain the correct video signal, then select the 6-/8-Channel Inputs to select the audio signal.

To select the 6-/8-Channel Inputs as the source, use either the Source Selector on the front panel or press the 6/8CH Input Selector on the remote. See Figure 73.



Figure 73 – 6-/8-Channel Input Selector

NOTE: The 6-/8-Channel Inputs pass the incoming signals directly to the volume control, without digitizing or processing them. Therefore, you will need to configure bass management settings (i.e., speaker size, delay and output level) on your source device so that they match the settings you programmed using EzSet/EQ, which may be viewed using the Manual Setup menu (see Advanced Functions section). Consult the owner's guide for your multichannel player for more information.

The multichannel analog audio connection is not required for DVD-Audio players compliant with HDMI version 1.1 or better, or HD-DVD and Blu-ray Disc players that decode the digital audio internally and output linear PCM signals in digital format. Consult the owner's guide for your disc player for more information.

Using the Tuner

The AVR 347's built-in tuner may be selected in one of three ways (see Figure 74):

- Press the Source Selector Button on the front panel repeatedly until the tuner is selected. The last-used band (AM or FM) will be active.
- Press the Tuner Band Button (marked AM/FM). Press this button again to switch bands. This will also enable you to select XM Radio, which is described separately in the next section.
- Press the Tuner Input Selector (marked AM/FM) on the remote. Press this button again to switch bands (AM, FM or XM).

OPERATION



Figure 74 – Tuner Input Selection

Radio stations may be selected in one of four ways (see Figure 75):

1. If you know the frequency number, enter it directly by first pressing the Direct Button on the remote, and then using the Numeric Keys.
2. After you have programmed Preset stations (see below), either enter the Preset number (1 through 30) using the remote or use the Preset Stations Buttons (front-panel or remote) to scroll through the list of presets.
3. In Auto tuning mode, with each press of the Tuning Buttons (front panel or remote), the AVR 347 will scan in the chosen direction until a station with acceptable signal strength is detected. Press the Tuning Button again to stop scanning.
4. In Manual tuning mode, with each press of the Tuning Buttons, the AVR 347 will tune the next frequency increment (0.1MHz for FM, or 10kHz for AM) in the selected direction. Press and hold the Tuning Button for faster scanning.



Figure 75 – Tuning a Station

Press the Tuning Mode Button (TUN-M on the remote) to switch between Auto and Manual tuning modes. See Figure 76. When an FM station has been tuned, pressing the Tuning Mode Button will switch between stereo and mono tuning, which may improve reception of weaker stations.



Figure 76 – Tuning Mode

To store a station in one of the 30 presets (see Figure 77):

1. Tune the desired station.
2. Press the Memory Button on the remote.
3. Use the Numeric Keys to enter the desired preset number.



Figure 77 – Storing a Preset Station

XM Radio Operation

XM Radio is a satellite-delivered service that offers hundreds of program channels, as well as local traffic and weather information for select cities. The AVR 347 is “XM Ready,” which means that it is able to receive the

XM service when an optional XM antenna module is connected and the service activated. As of this writing, the Audiovox® CNP 1000 “Connect and Play” module for home audio use and the XM Mini-Tuner and Home Dock (Models CNP-2000 and CNP-2000H) are compatible with the AVR 347. Additional modules may become available in the future. Modules produced for automotive, or “mobile,” use are not compatible with the AVR 347.

NOTE: To listen to XM Radio using the AVR 347, you will need to purchase an XM antenna module and subscription, and you will need to activate your module. (Note that XM service is not available in Alaska or Hawaii.) Visit the XM Radio Web site at www.xmradio.com for more information.

Plug the module into the XM Antenna Jack on the rear of the AVR 347. Place the antenna module so that it has a clear view through a south-facing window in order to obtain reception from the XM satellite.

Select XM Radio as the source in one of the following three ways (see Figure 78):

1. Press the Source Selector button on the front panel repeatedly until XM Radio is selected. XM will only appear in the Message Display.
2. Press the Tuner Band Button (front-panel or remote) repeatedly until XM Radio is selected.
3. Press the XM Radio Input Selector on the remote.



Figure 78 – XM Radio Source Selection

You should be able to tune in Channel 1, the Preview Channel, to confirm that your equipment is ready for activation. There are three ways to tune an XM Radio channel (see Figure 75):

1. Enter the channel number directly using the Numeric Keys on the remote. It is not necessary to press the Direct Button first.
2. Press the Tuning Buttons on the front panel or remote to scan through the channels. Auto tuning mode is not available.
3. The AVR 347 is capable of storing up to 40 XM Radio preset channels. The presets are divided into five banks, denoted by the letters A through E, with eight numeric presets per bank. After you have programmed preset stations (see below), you may select one by pressing the Set Button repeatedly until PRESET SEARCH appears, then using the ▲/▼ Buttons to change the bank (A through E). Use the Preset Buttons to scan through the eight numeric positions within a bank.

When you are able to hear Channel 1, you are ready to activate your module. If you don't hear Channel 1, make sure the module's plug is firmly seated in the XM Antenna jack, and that the module is near a south-facing window. Try unfolding the module and rotating it to obtain reception. You may need to purchase an extension cable, available on the XM Radio site, to ensure that the module is near the window.

OPERATION

Tune to Channel 0 for a display of your antenna module's Radio ID number, required for activation.

The current channel number and preset location will appear in the upper line of the Message Display, and the channel's name will appear in the lower line. Three signal-strength bars will appear to the right of the channel number and preset location. Press the Tuning Mode Button repeatedly to display the category, current artist or song title.

For traffic and weather channels, the current city's name will appear instead of the channel name, and pressing the Tuning Mode Button repeatedly will display the local weather and temperature.

Press the Set Button to search all channels. Press it again to search by category, using the ▲/▼ Buttons to change the category and then pressing the Set Button to tune the first available channel in the new category. Press the Set Button again to change the preset bank, using the ▲/▼ Buttons to change the bank letter. Press the Set Button again to return to the all-channel search.

To store a channel in one of the 40 preset locations:

1. Press the Set Button repeatedly until PRESET SEARCH appears, then use the ▲/▼ Buttons until the desired bank of presets (A through E) appears in the upper line of the message display.
2. Press the Memory Button, and a line will appear next to the preset bank letter.
3. Use the Numeric Keys to enter the preset location (1 through 8) you wish to store the channel in.

Recording

Two-channel analog and digital audio signals, as well as composite and S-video signals, are normally available at the appropriate recording outputs. Thus, to make a recording, you need only make sure to connect your audio or video recorder to the appropriate output jacks, as described in the Installation section, insert blank media and make sure the recorder is turned on and recording while the source is playing.

NOTES:

1. Analog audio signals are not converted to digital form, and digital audio signals are not converted to analog audio form. However, you may record a coaxial or optical digital audio source using either type of digital audio output.
2. Only PCM digital audio signals are available for recording. Proprietary formats such as Dolby Digital and DTS may not be recorded using the digital audio connections, although if the source is connected to the AVR using the analog audio connections, an analog recording may be made.
3. Component video and HDMI sources are not available for recording.
4. Please make certain that you are aware of any copyright restrictions on any material you record. Unauthorized duplication of copyrighted materials is prohibited by federal law.

Using The Bridge™

The Bridge is an optional dock that may be used with a compatible iPod (not included). When The Bridge is connected to its proprietary input on the AVR 347 and the iPod is docked, you may play the audio, video and still-image materials on your iPod through your high-quality audio/video system, operate the iPod using the AVR remote or the AVR's front-panel controls, view navigation messages on the AVR's front panel or a connected video display, and charge the iPod.

Either press the front-panel Source Selector repeatedly until the message "DMP/The Bridge is CONNECTED" scrolls across the front panel and appears in the semi-OSD display, or press the DMP Button on the remote to select The Bridge as the input source.

When an iPod is docked in The Bridge, the screen shown in Figure 79 will appear on a video display connected to the AVR. Navigate The Bridge's screens by using the ◀/▶ Buttons to highlight a line and pressing the Set Button to select the line. The ▶ Button scrolls down, and the ◀ Button scrolls up. Press the Menu Button to return to the previous level of The Bridge's menu system. Remember to set the remote in The Bridge device mode by pressing the Tape/The Bridge Button. If it lights in red, press it again quickly so that it lights in green, indicating it is in The Bridge mode.

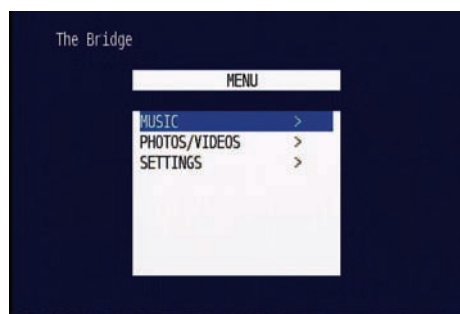

Figure 79 – The Bridge: Main Menu Screen

MUSIC: This line allows you to navigate the audio materials stored on your iPod.

PHOTOS/VIDEOS: Selecting this item allows you to play still images or videos stored on the iPod. The screen shown in Figure 80 will appear, directing you to operate the iPod's own controls directly to play images and videos. You may use the AVR 347 remote instead of the iPod's controls to navigate it. Visual materials will be displayed on a video display connected to the AVR.

NOTE: After selecting video/photo viewing, the AVR may remain in iPod Manual Mode, even after undocking the iPod or switching to another source input and back again. To return to normal operation, with the AVR remote in The Bridge mode, press and hold the Menu Button.

OPERATION



Figure 80 – The Bridge: Playing Images and Videos

SETTINGS: This line accesses the Settings menu, shown in Figure 81. The items in this menu enable you to use the Shuffle and Repeat functions on the iPod. You may also set the Resume function, which resumes play of a selection from the point at which it was stopped,

NOTE: iTunes allows you to set certain selections to always or never remember playback position, or to be skipped in Shuffle mode. The AVR 347's settings cannot override these iTunes settings.



Figure 81 – The Bridge: Settings Menu Screen



Figure 82 – Using The Bridge (Remote)



Figure 83 – Using The Bridge (Front Panel)

Table 7 summarizes the controls available when The Bridge is in use. See also Figures 82 and 83.

Table 7 – Using The Bridge

iPod Function	Remote Control Key	Front-Panel Button
Play	Play (▶)	Tuner Mode
Pause	Pause (⏸)	Tuner Mode
Menu	Menu (Spkr)	Tuner Band (AM/FM)
Select	Set	Set
Scroll Forward	Left Arrow (◀)	Preset Down
Scroll Reverse	Right Arrow (▶)	Preset Up
Forward Search/Next Track	Forward/Next (▶▶)	Tuning Up
Reverse Search/Previous Track	Reverse/Previous (◀◀)	Tuning Down

NOTES:

- The Play and Pause functions are not available unless content has been selected for playback by navigating the menu system.
- For the Search function, press and hold the indicated button. Pressing the Previous Track Button once skips to the beginning of the current track. Press the Previous Track Button *twice* to skip to the beginning of the previous track.

While a selection is playing, the song title, artist and album name, if available on the iPod, will scroll across the upper line in the front-panel Message Display. The lower line will display the elapsed time of the track on the left, the play mode icon, and the time remaining on the right.

In addition, if a video display is connected to the AVR 347, a screen will appear briefly to display information about the iPod's status and the track. The top line will display the play mode icon, with the phrase "Now Playing" appearing to the right to indicate that you are viewing the status of the current track. Below that, the AVR displays the total number of tracks in the current playlist on the right (all materials on the iPod are considered one playlist) with the number of the current track on the left. The song title, artist and album are displayed. At the bottom of the screen is a graphic bar indicating the current play position within the track, with the elapsed and remaining times appearing below the bar.

After a period of time, the screen may disappear from view. The length of time is set using the Full-OSD Time-Out setting in the System Settings menu (described in the Advanced Functions section). You may restore the Now Playing screen to view by pressing either of the ◀/▶ Buttons, and you may then navigate the menus as explained above.

NOTE: It is strongly recommended that you use a screen saver built into your video display to avoid possible damage from "burn-in" that may occur with plasma and many CRT displays when a still image, such as a menu screen, remains on display for an extended period of time.

OPERATION

NOTES ON VIDEO PLAYBACK:

- Before attempting to play videos stored on your iPod, check the Video Settings menu on the iPod and make sure that the TV Out setting is set to On. The TV Signal setting should be NTSC to match the capabilities of your video display. Set Widescreen to On or Off, depending on the aspect ratio of your video display. If your selection was playing and paused at the time you changed the TV Out setting, the iPod may require you to navigate its menu system and reselect the video for the new TV Out setting to take effect. Resuming play from the Now Playing function may not reflect the change to the TV Out setting. This is a function of the iPod, not the AVR 347.
- In Video mode, the iPod's menus will not be visible on your video display, although you may view them on the iPod's screen. You may operate the iPod using the AVR remote, as long as it is in The Bridge device mode.
- You may view the AVR's on-screen displays while The Bridge is in use, just as you would with any other video source.
- The MP4 and H.264 video formats often used for videos to be played on the iPod are intended for optimal performance on the iPod's small screen. Playback on larger displays may have different results.

Selecting a Surround Mode

Surround mode selection can be as simple or sophisticated as your individual system and tastes. Feel free to experiment with the many available surround modes on the AVR 347, and you may find a few that become your favorites for certain sources or program types. Although more detailed information on surround modes may be found in the Advanced Functions section, it is easy to select any of the modes available at a given time:

To select a surround mode using the front-panel controls, press the Surround Mode Button repeatedly until the desired group of modes is selected: Logic 7, Dolby, DTS, DSP or Stereo. Then press the Surround Select Button repeatedly to select the desired mode within the group. See Figure 84.



Figure 84 – Select a Surround Mode (Front Panel)

To select a surround mode using the remote control, locate the button dedicated to the desired group of modes: Logic 7, Dolby Sur, DTS Sur, DTS Neo:6, Surr (DSP) or Stereo. Press that button repeatedly to select the desired mode. See Figure 85.

To select a surround mode using the full-OSD menu system, press the OSD Button to display the Menu System. Use the ▲/▼ Buttons to highlight the Surround tab, and press the Set Button to access the

Surround Setup menu, as shown in Figure 86. With the Surround Mode highlighted, press the Set Button to change the surround mode group. Use the ◀/▶ Buttons to scroll through the options, and press the Set Button when the desired mode group appears. Navigate to the Mode line and follow the same procedure to select an individual mode. As explained in the Advanced Functions section, there are also some additional settings that may be made.



Figure 85 – Select a Surround Mode (Remote)

You are now ready to enjoy the best in home theater entertainment with your AVR 347. As you become more familiar with the receiver, you may wish to explore some of its advanced functions, which are described in the following section.

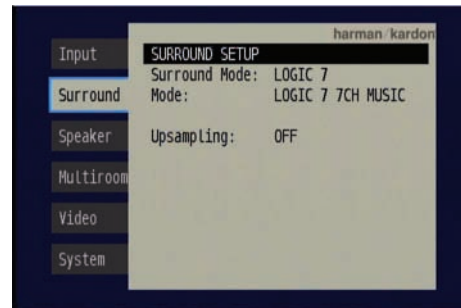

Figure 86 – Surround Setup Menu Screen

TROUBLESHOOTING GUIDE

SYMPTOM	CAUSE	SOLUTION
Unit does not function when Main Power Switch is pushed	<ul style="list-style-type: none"> No AC Power 	<ul style="list-style-type: none"> Make certain AC power cord is plugged into a live outlet Check to see whether outlet is switch-controlled
Display lights, but no sound or picture	<ul style="list-style-type: none"> Intermittent input connections Mute is on Volume control is down 	<ul style="list-style-type: none"> Make certain that all input and speaker connections are secure Press Mute Button Turn up volume control
No sound from any speaker; light around power switch is red	<ul style="list-style-type: none"> Amplifier is in protection mode due to possible short Amplifier is in protection mode due to internal problems 	<ul style="list-style-type: none"> Check speaker wire connections for shorts at receiver and speaker ends Contact your local Harman Kardon service center
No sound from surround or center speakers	<ul style="list-style-type: none"> Incorrect surround mode Input is monaural Incorrect configuration Stereo or Mono program material 	<ul style="list-style-type: none"> Select a mode other than Stereo There is no surround information from mono sources Check speaker mode configuration The surround decoder may not create center- or rear-channel information from nonencoded programs
Unit does not respond to remote commands	<ul style="list-style-type: none"> Weak batteries in remote Wrong device selected Remote sensor is obscured 	<ul style="list-style-type: none"> Change remote batteries Press the AVR selector Make certain front panel sensor is visible to remote or connect an optional remote sensor
Intermittent buzzing in tuner	<ul style="list-style-type: none"> Local interference 	<ul style="list-style-type: none"> Move unit or antenna away from computers, fluorescent lights, motors or other electrical appliances
Letters flash in the channel indicator display and digital audio stops	<ul style="list-style-type: none"> Digital audio feed paused 	<ul style="list-style-type: none"> Resume play for DVD Check that correct digital input is selected
Surround Back Speaker settings cannot be accessed, and test tone does not play through Surround Back Speakers	<ul style="list-style-type: none"> Multiroom system has been turned on, and the surround back channels were reassigned to multiroom operation 	<ul style="list-style-type: none"> Use the OSD menu system to access the MULTI ROOM SETUP menu and change the SB Amps setting to MAIN.
The XM Preview Channel (001) is silent	<ul style="list-style-type: none"> XM antenna is not plugged in XM antenna is not located in such a way as to enable reception 	<ul style="list-style-type: none"> Make sure you are using a home audio XM antenna module designed for use with XM Ready home audio equipment, and that the module is plugged into the XM Radio Jack on the rear panel of the receiver. The XM Antenna module needs to be placed with an unobstructed view of the southern sky, or within range of an XM terrestrial repeater. If necessary, purchase an extension cable from your XM Radio dealer.
Unable to activate Program mode on remote	<ul style="list-style-type: none"> Input Selector not held for at least 3 seconds. 	<ul style="list-style-type: none"> The selector will light as you initially press it, and go dark as you hold it down. Wait at least 3 seconds for the selector to light up again, and the Program LED will flash.
Unable to assign a device to HDMI 1 or 2 selectors	<ul style="list-style-type: none"> Invalid device assignment attempted. 	<ul style="list-style-type: none"> Only the DVD, VCR (includes DVR), cable or satellite (CBL/SAT selector) devices may be assigned to the HDMI 1 or 2 selectors.
Remote behaves erratically	<ul style="list-style-type: none"> Buttons are pressed too hard. 	<ul style="list-style-type: none"> Always press remote control buttons as gently as possible.

Additional information on troubleshooting possible problems with your AVR 347, or installation-related issues, may be found in the list of "Frequently Asked Questions," which is located in the Product Support section of our Web site at www.harmankardon.com.

Erasing Macros

It isn't possible to "edit" a command within a macro. However, you may erase the macro as follows:

- Simultaneously press and hold the Mute Button and the Macro Button containing the macro until the LED flashes.
- Press the Surround Button to erase the macro.

Resetting the Remote

To reset the remote to its factory defaults, simultaneously press and hold any Input Selector and the "0" Numeric key. When the Program LED flashes in amber, enter the code "333". When the green LED goes out, the remote will have been fully reset.

Processor Reset

There may be instances when you wish to fully reset the AVR 347 to its factory defaults, or the unit may behave erratically after a power surge. To correct erratic behavior, first try turning the Master Power Switch off and unplugging the AC power cord for at least three minutes. Plug the cord back in and turn the receiver back on. If this doesn't help, try a system reset.

NOTES:

- A system reset erases all user configurations, including speaker and level settings and tuner presets. After a reset, you will need to reenter all of these settings.
- The RS-232 Reset Button on the rear panel of the AVR 347 does not perform a system reset. DO NOT press the RS-232 Reset Button.

To reset the AVR 347, place the receiver in Standby mode (press the front-panel Standby/On Switch so that the Power Indicator turns amber). Then press and hold the front-panel Tone Mode Button for at least five seconds until the RESET message appears in the display.

Memory

If the AVR 347 is unplugged or experiences a power outage, it will retain user settings for up to four weeks.

DISASSEMBLY

1. Removing the Top Cabinet
Remove the Screws

① ~ ⑬

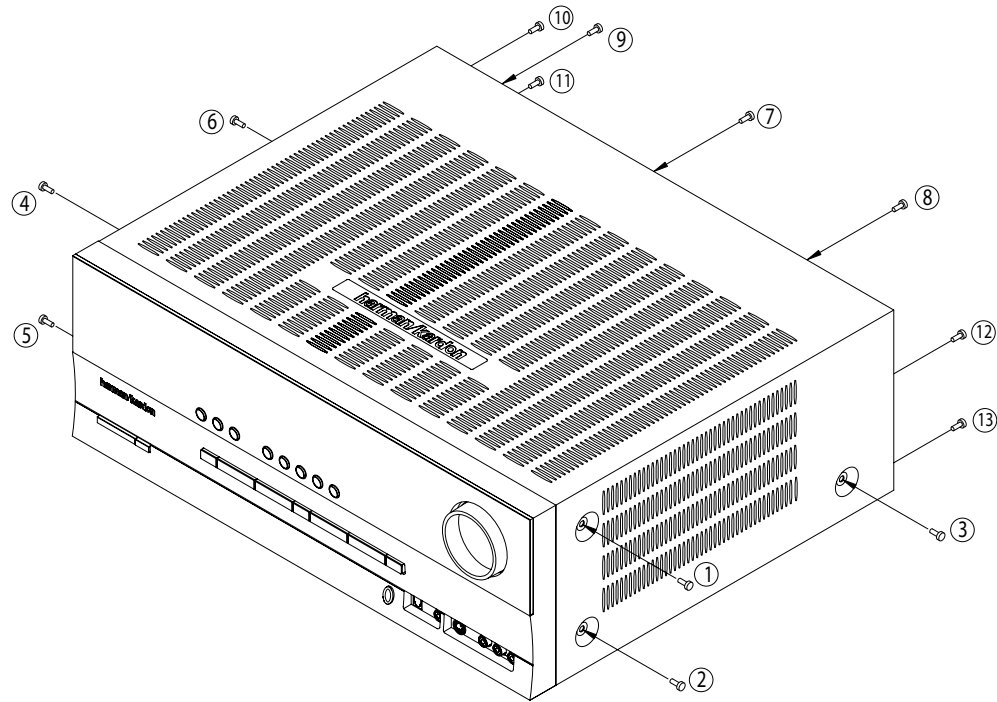

2. Removing the Front Panel
Remove the Screws

① ~ ⑨

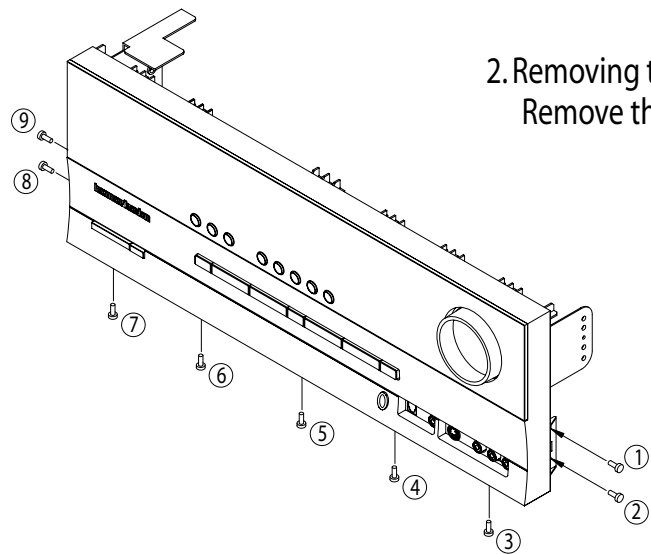

3. Removing the Rear Panel
Remove the Screws

① ~ ③⑧

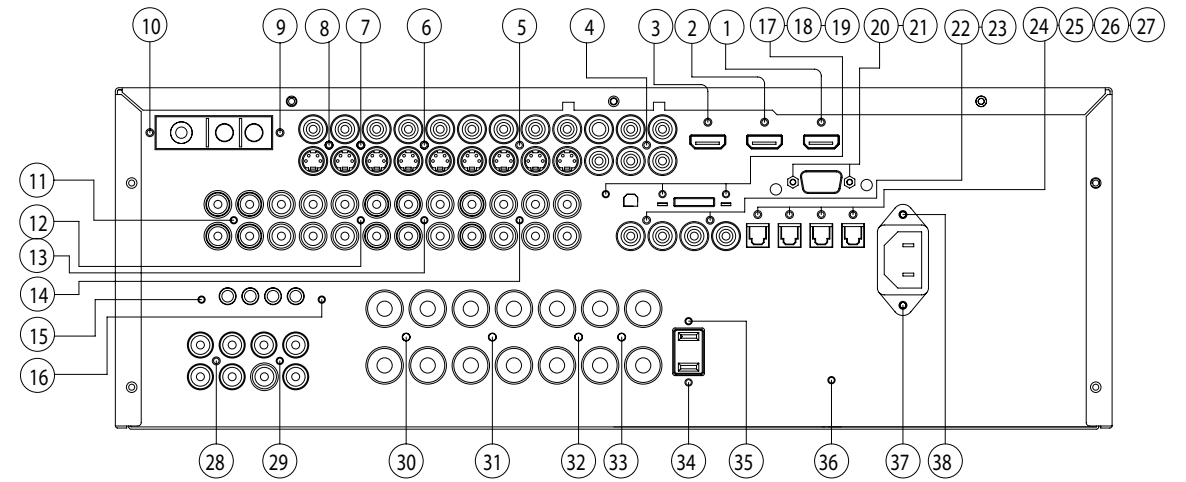

4. Removing the Main PCB
Remove the Screws

① ~ ⑦

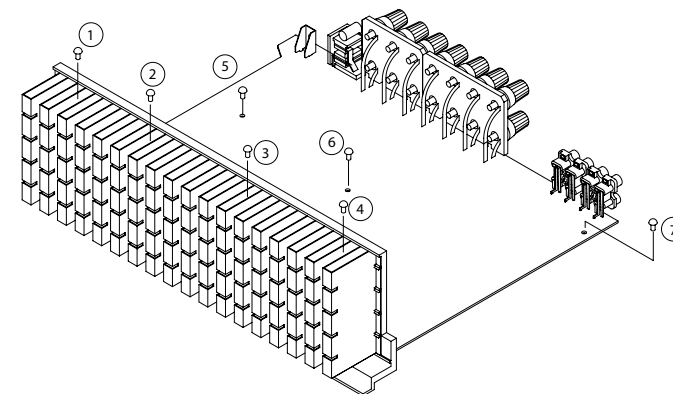

AVR347 DISASSEMBLY PROCEDURE

1 TOP-CABINET (21) REMOVAL

1. Remove 13 screws (S1,S7) and then remove the Top-cabinet.

2 FRONT PANEL ASS'Y REMOVAL

1. Remove the Top-cabinet, referring to the previous step 1.
2. Disconnect the card cable between connector (CN72-17p) on the Fip PCB (37-1) and connector (CN72) on the Input PCB (39-1).
3. Disconnect the lead wire (BN81-8P) on the Fip PCB (37-1) from connector (CN81) on the Trans PCB (40-4).
4. Disconnect the lead wire (BN22-6P) on the Phone PCB (37-5) from connector (CN22) on the Input PCB (39-1).
5. Disconnect the lead wire (BN18-5P) on the Phone PCB (37-5) from connector (CN18) on the Input PCB (39-1).
6. Disconnect the lead wire (BN10-4P) on the Volume PCB (37-6) from connector (CN10) on the Input PCB (39-1).
7. Disconnect the lead wire (BN41-6P) on the Volume PCB (37-6) from connector (CN41) on the Video PCB (41).
8. Disconnect the lead wire (BN90-2P) on the Main PCB (38-1) from connector (CN86) on the Moms PCB (37-4).
9. Remove 1 screw (S10) and then lead wire (JW82-1P,JW83-1P) on the Phone PCB (37-5).
10. Remove 1screw (S10) and then lead wire (JW84-1P) on the Volume PCB (37-3).
11. Remove 10 screws (S1) and then remove the Front Panel ASS'Y.

3 Volume PCB (37-6) REMOVAL

1. Remove the Top-cabinet, referring to the previous step 1.
2. Remove the Front Panel ASS'Y, referring to the previous step 2.
3. Pull out the Volume Knob ASS'Y.
4. Disconnect connector (CN84) on the Volume PCB (37-6) from the lead wire (BN84-5P) on the Fip PCB (37-1).
5. Disconnect the lead wire (BN92-5P) on the Volume PCB (37-6) from connector (CN92) on the Phone PCB (37-5).
6. Remove 8 screws (S2,S14), and then remove the Volume PCB (37-6).

4 PHONE PCB (37-5) REMOVAL

1. Remove the Top-cabinet, referring to the previous step 1.
2. Remove the Front Panel ASS'Y, referring to the previous step 2.
3. Disconnect connector (CN92) on the Phone PCB (37-5) from the lead wire (BN92-5P) on the Volume PCB (37-6).
- 4.. Disconnect connector (CN85)on the Phone PCB (37-5) from the lead wire (BN85-3P) on the Fip PCB (37-1).
5. Remove 2 screws (S2) and then remove the Phone PCB (37-5).

5 POWER LED PCB (37-3) REMOVAL

1. Remove the Top-cabinet, referring to the previous step 1.
2. Remove the Front Panel ASS'Y, referring to the previous step 2.
3. Disconnect connector (CN88) on the Power Led PCB (37-3) from the lead wire (BN88-4P) on the Fip PCB (37-1) .
4. Remove 2 screws (S2) and then remove the Power led PCB (37-3).

6 FIP PCB (37-1) REMOVAL

1. Remove the Top-cabinet, referring to the previous step 1.
2. Remove the Front Panel ASS'Y, referring to the previous step 2.
3. Disconnect the lead wire (BN84-5P) on the Fip PCB (37-1) from connector (CN84) on the Volume PCB (37-6).
4. Disconnect the lead wire (BN85-3P) on the Fip PCB (37-1) from connector (CN85) on the Phone PCB (37-5).
5. Disconnect the lead wire (BN88-4P) on the Fip PCB (37-1) from connector (CN88) on the Power Led PCB (37-3).

6. Disconnect the connector (CN89) on the Fip PCB (37-1) from lead wire (BN89-4P) on the Key PCB (37-2).
7. Remove 3 screws (S2) and then remove the Guide PCB (37-8) & the Fip PCB (37-1).

7 KEY PCB (37-2) REMOVAL

1. Remove the Top-cabinet, referring to the previous step 1.
2. Remove the Front Panel ASS'Y, referring to the previous step 2.
3. Remove the Fip PCB (37-1), referring to the previous step 6.
4. Remove 10 screws (S2) and then remove the Key PCB (37-2).

8 TUNER MODULE (43) REMOVAL

1. Remove the Top-cabinet, referring to the previous step 1.
2. Disconnect the card cable between connector (CON1-13P) on the Tuner module (43) and connector (CN13) on Input PCB (39-1).
3. Remove 2 screws (S8) and then remove the Tuner Module (43).

9 HUDSON PCB (42) REMOVAL

1. Remove the Top-cabinet, referring to the previous step 1.
2. Disconnect connector (CN80) on the HUDSON PCB (42) from the lead wire (BN80-3P) on the RS232 PCB (37-7).
3. Remove 3 screws (S15).
4. Disconnect the board to board connector between and connector (CN81-44P) on the HUDSON PCB (42) and connector (BN81-44P) on VIDEO PCB (41) and then remove the HUDSON PCB (42).

10 VIDEO PCB (41) REMOVAL

1. Remove the Top-cabinet, referring to the previous step 1.
2. Remove the Hudson PCB (42), referring to the previous step 9.
3. Disconnect the card cable between connector (BN14-17p) on the Video PCB (41) and connector (CN14) on the Input PCB (39-1).
4. Disconnect connector (CN43) on the Video PCB (41) from the lead wire (BN43-3P) on the Regulator PCB (A)(40-2).
5. Disconnect connector (CN41) on the Video PCB (41) from the lead wire (BN41-6P) on the Volume PCB (37-6).
6. Disconnect the card cable between connector (CN42) on the Video PCB (41) and connector (BN44-11P) on the iPod PCB (39-2).
7. Disconnect the card cable between connector (BN15-15P) on Video PCB (41) and connector (CN15-15P) on INPUT PCB (39-1).
8. Remove 6 screws (S8) and then remove the Video PCB (41).

11 iPod PCB (39-2) REMOVAL

1. Remove the Top-cabinet, referring to the previous step 1.
2. Remove the Hudson PCB (42), referring to the previous step 9.
3. Remove the Video PCB (41), referring to the previous step 10
4. Disconnect the card cable between connector (BN19-15P) on the the iPod PCB (39-2) and connector (CN19) on the PCB (39-1).
5. Disconnect the card cable between connector (BN44-11P) on the iPod PCB (39-2) and connector (CN42) on the Video PCB (41).
6. Disconnect the card cable between connector (CN47-7P) on the iPod PCB (39-2) and connector (CN47) on the RS232 PCB (37-7).
7. Disconnect the board to board connector between and connector (CN23) on the XM PCB (39-4) and connector (BN17-12P) on the iPod PCB (39-2).
8. Remove 2 screws (S13) and then remove the iPod PCB (39-2).

12 XM PCB (39-4) REMOVAL

1. Remove the Top-cabinet, referring to the previous step 1.
2. Remove the Hudson PCB (42), referring to the previous step 9.
3. Remove the Video PCB (41), referring to the previous step 10

4. Disconnect the card cable between connector (BN21-7P) on XM PCB (39-4) and connector (CN21) on the input PCB (39-1).
5. Disconnect the lead wire (BN85-2P) on the XM PCB (39-4) from connector (CN85) on the Regulator PCB (A)(40-2).
6. Disconnect the board to board connector between and connector (CN23) on the XM PCB (39-4) and connector (BN17-12P) on the iPod PCB (39-2).
7. Remove 1 screw (S15) and then remove the XM PCB (39-4).

13 RS232 PCB (37-7) REMOVAL

1. Remove the Top-cabinet, referring to the previous step 1.
2. Remove the Hudson PCB (42), referring to the previous step 9.
3. Remove the Video PCB (41), referring to the previous step 10.
4. Disconnect the card cable between connector (CN47-7P) on the iPod PCB (39-2) and connector (CN47) on the RS232 PCB (37-7).
5. Remove 2 screws and then remove the RS232 PCB (37-7).

14 INPUT PCB (39-1) REMOVAL

1. Remove the Top-cabinet, referring to the previous step 1.
2. Remove the Tuner module (44), referring to the previous step 8.
3. Remove the Hudson PCB (42), referring to the previous step 9.
4. Remove the Video PCB (41), referring to the previous step 10.
5. Disconnect connector (CN20) on the Input PCB (39-1) from the lead wire (BN20-5P) on the Regulator PCB (B)(40-5).
6. Disconnect connector (CN22) on the Input PCB (39-1) from the lead wire (BN22-6P) on the Phone PCB (37-5).
7. Disconnect connector (CN18) on the Input PCB (39-1) from the lead wire (BN18-5P) on the Phone PCB (37-5).
8. Disconnect connector (CN10) on the Input PCB (39-1) from the lead wire (BN10-4P) on the Volume PCB (37-6).
9. Disconnect the card cable between connector (CN14) on the Input PCB (39-1) and connector (BN14-17P) on the Video PCB (41).
10. Disconnect the card cable between connector (CN19) on the Input PCB (39-1) and connector (BN19-15P) on I-Pod PCB (39-2).
11. Disconnect the card cable between connector (CN21) on the input PCB (39-1) and connector (BN21-7P) on XM PCB (43).
12. Disconnect the card cable between connector (CN12-21p) on Input PCB (39-1) and connector (CN12-21p) on the PCB (38-1)
13. Disconnect the card cable between connector (CN11-17p) on the Input PCB (39-1) and connector (CN11) on the main PCB (38-1)
14. Disconnect the card cable between connector (CN72) on the Input PCB (39-1) and connector (CN72-17p) on the Fip PCB (37-1)
15. Disconnect the card cable between connector (CN16-12P) on the Input PCB (39-1) and connector (BN16) on A-BUS PCB (39-3)
16. Remove 11 screws (S8,S15) and then remove the Input PCB (39-1).

15 POWER TRANS (36) & POWER PCB ASS'Y (40) REMOVAL

1. Remove the Top-cabinet, referring to the previous step 1.
2. Disconnect lead wire of the Power Trans (36) from connector (CN91-3P) on the Main PCB (38-1)
3. Disconnect connector (CN19-3P,CN20-4P) on TRANS PCB (40-3) from the lead wire (BN19-3P,BN20-4P) on the Main PCB (38-1).
4. Disconnect the lead wire (BN96-8P) on the Power PCB (40-4) from connector (CN96) on the Regulator PCB (B)(40-5).
5. Disconnect the lead wire (BN99-8P) on the Power PCB (40-4) from connector (CN99) on the Regulator PCB (A)(40-2).
6. Disconnect connector (CN81) on the Trans PCB (40-4) from the lead wire (BN81-8P) on the Fip PCB (37-1).
7. Remove 4 Trans screws (S9) and then remove the Power Trans (36) & Power PCB ASS'Y (40) REMOVAL .

16 REMOTE PCB ASS'Y (40-7) REMOVAL

1. Remove the Top-cabinet, referring to the previous step 1.
2. Disconnect connector (CN88) on the remote PCB (40-7) from the lead wire (BN88-6P) on the Main PCB (38-1)
3. Remove 3 screws (S13) and then remove the Remote PCB ASS'Y (40-7).

17 A-BUS'Y (39-3) REMOVAL

1. Remove the Top-cabinet, referring to the previous step 1.
2. Disconnect connector (CN90-2P) on the Regulator (C) PCB (39-6) from the lead wire (BN90) on the A-BUS PCB (39-3).

3. Disconnect the card cable between connector (CN16-12P) on Input PCB (39-1) and connector (BN16-12P) on A-BUS PCB (39-3).
4. Remove 3screws (S13) and then remove the A-BUS PCB ASS'Y (39-3).

18 MAIN PCB ASS'Y (38-1) REMOVAL

1. Remove the Top-cabinet, referring to the previous step 1.
2. Remove the Tuner module (43), referring to the previous step 8.
3. Remove the Hudson PCB (42), referring to the previous step 9.
4. Remove the Video PCB (41), referring to the previous step 10.
5. Remove the iPod PCB (39-2), referring to the previous step 11.
6. Remove the XM PCB (39-4), referring to the previous step 12.
7. Remove the RS232 PCB (37-7), referring to the previous step 13.
8. Remove the Input PCB (39-1), referring to the previous step 14.
9. Remove the A-BUS PCB (39-3), referring to the previous step 17.
10. Remove the AC Cord wire from the connector (CN92-2P) of the Main PCB (38-1)
11. Disconnect the lead wire (BN90-2P) on the Main PCB (38-1) from connector (CN86) on Mems PCB (37-4).
12. Disconnect connector (CN91-3P) on the Main PCB (38-1) from lead wire of the Power Trans (36)
13. Disconnect the lead wire (BN89-2P) on the Main PCB (38-1) from connector (CN89) on Regulator PCB (C)(39-6).
14. Disconnect the lead wire (BN19-3P, BN20-4P) on Main PCB (38-1) from connector (CN19-3P, CN20-4P) on TRANS PCB (40-4).
15. Disconnect the lead wire (BN88-6P) on the Main PCB (38-1) from connector (CN88) on remote PCB (40-7).
16. Disconnect the lead wire of the DC, FAN(49) from connector (CN89-2P) on the Main PCB (38-1).
17. Disconnect the lead wire (BN97-3P) on the Main PCB (38-1) from connector (CN97) on Regulator PCB (C)(39-6).
18. Remove 11screws (S13-1EA, S4-2EA, S6-2EA, S8-6EA) and then remove the Main PCB ASS'Y (38-1).

AVR 347 EXPLODED VIEW

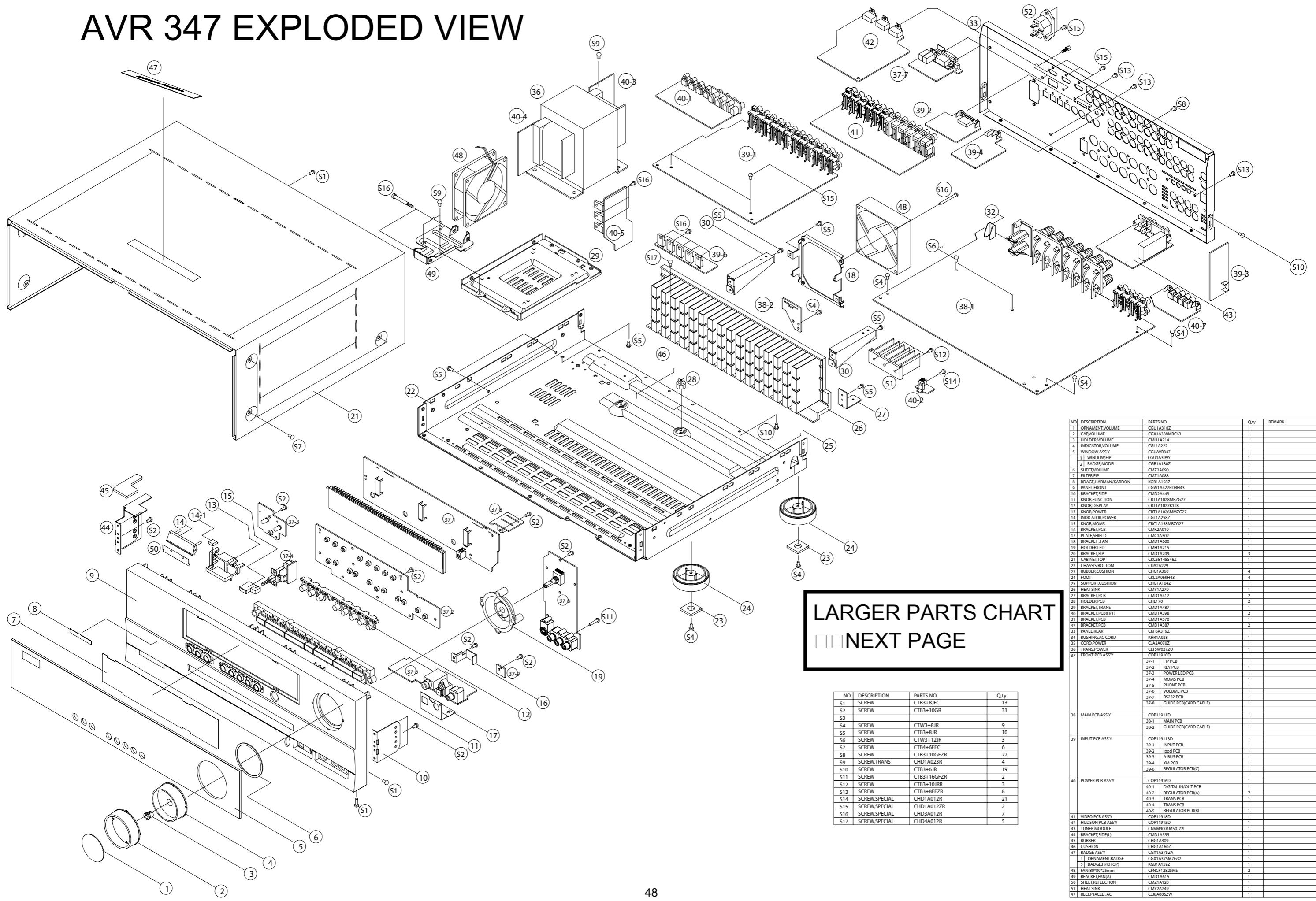

LARGER PARTS CHART
 NEXT PAGE

NO	DESCRIPTION	PARTS NO.	Q.ty
S1	SCREW	CTB3+8JFC	13
S2	SCREW	CTB3+10GR	31
S3			
S4	SCREW	CTW3+8JR	9
S5	SCREW	CTB3+8JR	10
S6	SCREW	CTW3+12JR	3
S7	SCREW	CTB4+6FFC	6
S8	SCREW	CTB3+10GFZR	22
S9	SCREW,TRANS	CHD1A023R	4
S10	SCREW	CTB3+6JR	19
S11	SCREW	CTB3+16GFZR	2
S12	SCREW	CTB3+10JRR	3
S13	SCREW	CTB3+8FFZR	8
S14	SCREW,SPECIAL	CHD1A012R	21
S15	SCREW,SPECIAL	CHD1A012ZR	2
S16	SCREW,SPECIAL	CHD3A012R	7
S17	SCREW,SPECIAL	CHD4A012R	5

NO	DESCRIPTION	PARTS NO.	Q.ty	REMARK
1	ORNAMENT,VOLUME	CGU1A318Z	1	
2	CAP,VOLUME	CGX1A38MBC63	1	
3	HOLDER,VOLUME	CMH1A214	1	
4	INDICATOR,VOLUME	CGL1A22Z	1	
5	WINDOW ASSY	CGUAVR347	1	
1	WINDOW,FIP	CGU1A399Y	1	
2	BADGE,MODEL	CGB1A180Z	1	
6	SHEET,VOLUME	CMZ2A090	1	
7	FILTER,FIP	CMZ1A088	1	
8	BDAGE,HARMAN/KARDON	KGB1A158Z	1	
9	PANEL,FRONT	CGW1A42RDRH43	1	
10	BRACKET,SIDE	CMD2A443	1	
11	KNOB,FUNCTION	CBT1A1028MBZG27	1	
12	KNOB,DISP,AY	CBT1A1027K128	1	
13	KNOB,POWER	CBT1A1026MMZG27	1	
14	INDICATOR,POWER	CGL1A258Z	1	
15	KNOB,MOMS	CBT1A158MBZG27	1	
16	BRACKET,PCB	CMK2A010	1	
17	PLATE,SHIELD	CMK1A302	1	
18	BRACKET,FAN	CMD1A600	1	
19	HOLDER,LED	CMH1A215	1	
20	BRACKET,FIP	CMD1A209	3	
21	CABINE, TOP	CKC3B145546Z	1	
22	CHASSIS,BOTTOM	CJUA2429	1	
23	RUBBER,CUSHION	CHG1A360	4	
24	FOOT	CKL2A069H43	4	
25	SUPPORT,CUSHION	CHG1A104Z	1	
26	HEAT SINK	CMY1A270	1	
27	BRACKET,PCB	CMH1A417	2	
28	HOLDER,PCB	CHET170	2	
29	BRACKET,TRANS	CMD1A487	1	
30	BRACKET,PCB(H/T)	CMD1A398	2	
31	BRACKET,PCB	CMD1A570	1	
32	BRACKET,PCB	CMD1A387	2	
33	PANEL,REAR	CKF6A319Z	1	
34	BUSHING,AC CORD	KHR1A028	1	
35	CORD,POWER	CJAZA070Z	1	
36	TRANS,POWER	CLTSW027ZU	1	
37	FRONT PCB ASSY	COP11910D	1	
		37-1	FIP PCB	1
		37-2	KEY PCB	1
		37-3	POWER LED PCB	1
		37-4	MOMS PCB	1
		37-5	PHONE PCB	1
		37-6	VOLUME PCB	1
		37-7	RS232 PCB	1
		37-8	GUIDE PCB(CARD CABLE)	1
38	MAIN PCB ASSY	COP11911D	1	
		38-1	MAIN PCB	1
		38-2	GUIDE PCB(CARD CABLE)	1
39	INPUT PCB ASSY	COP11913D	1	
		39-1	INPUT PCB	1
		39-2	ipod PCB	1
		39-3	A-BUS PCB	1
		39-4	XM PCB	1
		39-6	REGULATOR PCB(C)	1
40	POWER PCB ASSY	COP11916D	1	
		40-1	DIGITAL IN/OUT PCB	1
		40-2	REGULATOR PCB(A)	7
		40-3	TRANS PCB	1
		40-4	TRANS PCB	1
		40-5	REGULATOR PCB(B)	1
41	VIDEO PCB ASSY	COP11918D	1	
42	HUDSON PCB ASSY	COP11915D	1	
43	TUNER MODULE	CNV9901M50U72L	1	
44	BRACKET,SIDE(L)	CMD1A555	1	
45	RUBBER	CHG1A309	1	
46	CUSHION	CHG1A160Z	1	
47	BADGE ASSY	CGX1A375ZA	1	
		CGX1A375MTG32	1	
		2	BADGE,H/K(TOP)	1
48	FAN(80*80*25mm)	CFNCF12825MS	2	
49	BEACKET,FANIA)	CMD1A615	1	
50	SHEET,REFLECTION	CMZ1A120	1	
51	HEAT SINK	CMY2A49	1	
52	RECEPTACLE, AC	CJBA006Z	1	

NO	DESCRIPTION	PART NO.	Q,ty	REMARK
1	ORNAMENT,VOLUME	CGU1A318Z	1	
2	CAP,VOLUME	CGX1A338MBC63	1	
3	HOLDER,VOLUME	CMH1A214	1	
4	INDICATOR,VOLUME	CGL1A222	1	
5	WINDOW ASS'Y	CGUAVR347	1	
	1 WINDOW,FIP	CGU1A399Y	1	
	2 BADGE,MODEL	CGB1A180Z	1	
6	SHEET,VOLUME	CMZ2A090	1	
7	FILTER,FIP	CMZ1A088	1	
8	BADGE,HARMAN/KARDON	KGB1A158Z	1	
9	PANEL,FRONT	CGW1A427RDRH43	1	
10	BRACKET,SIDE	CMD2A443	1	
11	KNOB,FUNCTION	CBT1A1028MBZG27	1	
12	KNOB,DISPLAY	CBT1A1027K128	1	
13	KNOB,POWER	CBT1A1026MMZG27	1	
14	INDICATOR,POWER	CGL1A258Z	1	
15	KNOB,MOMS	CBC1A158MBZG27	1	
16	BRACKET,PCB	CMK2A010	1	
17	PLATE,SHIELD	CMC1A302	1	
18	BRACKET ,FAN	CMD1A600	1	
19	HOLDER,LED	CMH1A215	1	
20	BRACKET,FIP	CMD1A209	3	
21	CABINET,TOP	CKC5B145S46Z	1	
22	CHASSIS,BOTTOM	CUA2A229	1	
23	RUBBER,CUSHION	CHG1A360	4	
24	FOOT	CKL2A069H43	4	
25	SUPPORT,CUSHION	CHG1A104Z	1	
26	HEAT SINK	CMY1A270	1	
27	BRACKET,PCB	CMD1A417	2	
28	HOLDER,PCB	CHE170	2	
29	BRACKET,TRANS	CMD1A487	1	
30	BRACKET,PCB(H/T)	CMD1A398	2	
31	BRACKET,PCB	CMD1A570	1	
32	BRACKET,PCB	CMD1A387	2	
33	PANEL,REAR	CKF6A319Z	1	
34	BUSHING,AC CORD	KHR1A028	1	
35	CORD,POWER	CJA2A070Z	1	
36	TRANS,POWER	CLT5W027ZU	1	
37	FRONT PCB ASS'Y		1	
	37-1	FIP PCB	1	
	37-2	KEY PCB	1	
	37-3	POWER LED PCB	1	
	37-4	MOMS PCB	1	
	37-5	PHONE PCB	1	
	37-6	VOLUME PCB	1	
	37-7	RS232 PCB	1	
	37-8	GUIDE PCB(CARD CABLE)	1	
38	MAIN PCB ASS'Y		1	
	38-1	MAIN PCB	1	
	38-2	GUIDE PCB(CARD CABLE)	1	
39	INPUT PCB ASS'Y		1	
	39-1	INPUT PCB	1	
	39-2	ipod PCB	1	
	39-3	A-BUS PCB	1	
	39-4	XM PCB	1	
	39-6	REGULATOR PCB(C)	1	
40	POWER PCB ASS'Y		1	
	40-1	DIGITAL IN/OUT PCB	1	
	40-2	REGULATOR PCB(A)	7	
	40-3	TRANS PCB	1	
	40-4	TRANS PCB	1	
	40-5	REGULATOR PCB(B)	1	
41	VIDEO PCB ASS'Y		1	
42	HUDSON PCB ASS'Y		1	
43	TUNER MODULE	CNVM9001MS0J72L	1	
44	BRACKET,SIDE(L)	CMD1A555	1	
45	RUBBER	CHG1A309	1	
46	CUSHION	CHG1A160Z	1	
47	BADGE ASS'Y	CGX1A375ZA	1	
	1 ORNAMENT,BADGE	CGX1A375M7G32	1	
	2 BADGE,H/K(TOP)	KGB1A159Z	1	
48	FAN(80*80*25mm)	CFNCF12825MS	2	
49	BRACKET,FAN(A)	CMD1A615	1	
50	SHEET,REFLECTION	CMZ1A120	1	
51	HEAT SINK	CMY2A249	1	
52	RECEPTACLE ,AC	CJ8A006ZW	1	

AMPLIFIER SECTION BIAS ADJUSTMENT

Measurement condition

.No input signal or volume position is minimum.

Standard value

.Ideal current = 48mA ($\pm 5\%$)

.Ideal DC Voltage = 25.92mV ($\pm 5\%$)

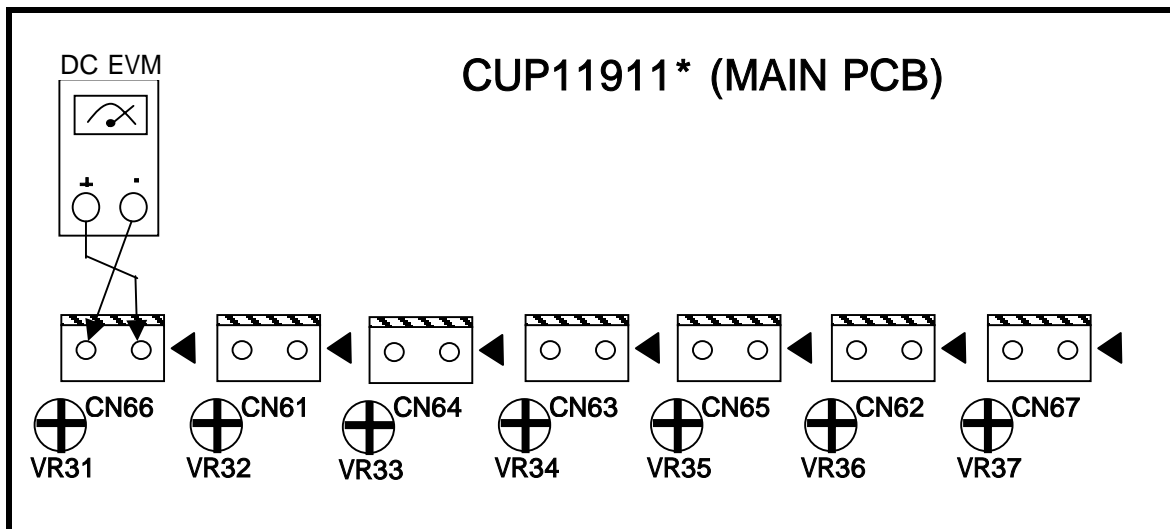

DC VOLTMETER ; Connect to

CN66(SL),CN61(CEN),CN64(SR),CN63(FL),CN65(SBL),CN62(FR),CN67(SBR)

NO.	Channel	Adjust for	Adjustment
1	Front Left	25.92mV ($\pm 5\%$)	CN63
2	Front Right	25.92mV ($\pm 5\%$)	CN62
3	Center	25.92mV ($\pm 5\%$)	CN61
4	Surround Left	25.92mV ($\pm 5\%$)	CN66
5	Surround Right	25.92mV ($\pm 5\%$)	CN64
6	Surround Back Left	25.92mV ($\pm 5\%$)	CN65
7	Surround Back Right	25.92mV ($\pm 5\%$)	CN67

AVR347/345 BLOCK DIAGRAM

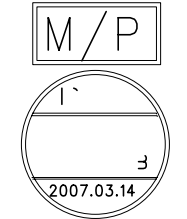
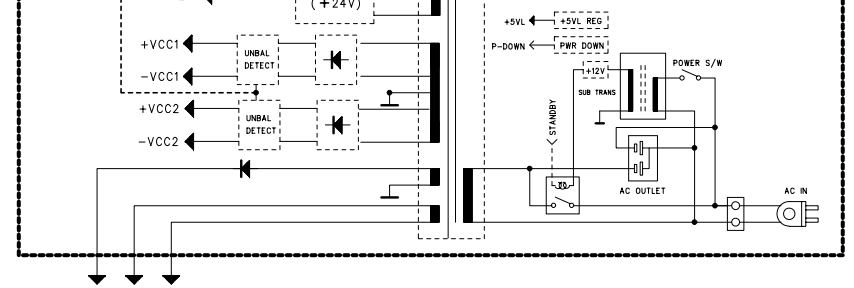
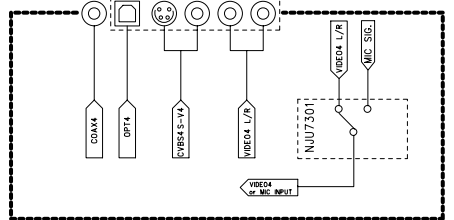
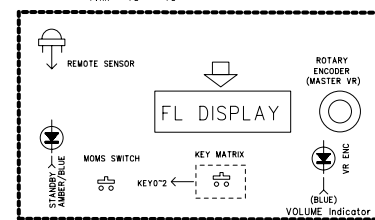
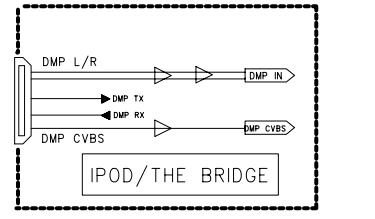
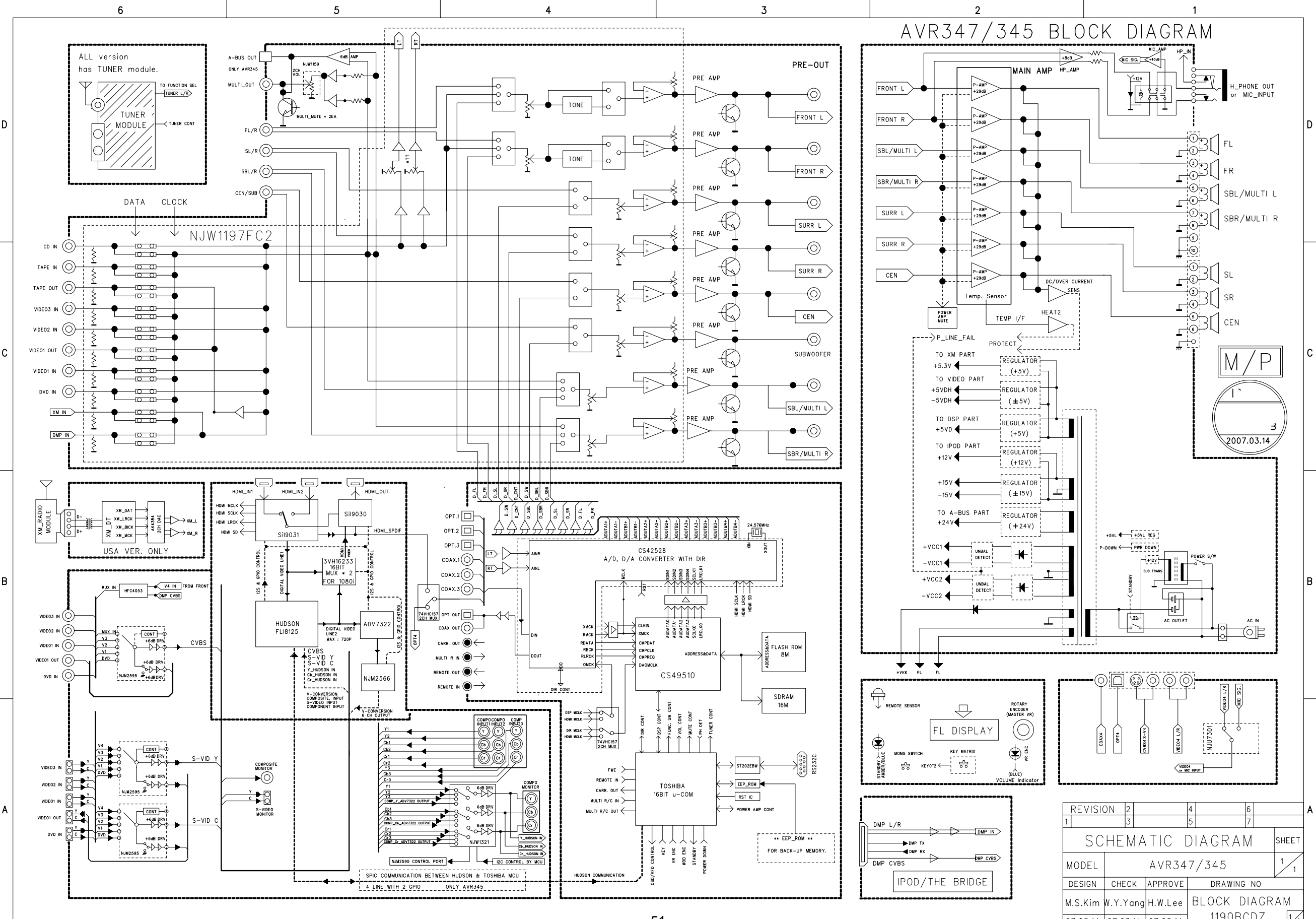

REVISION	2	4	6
1	3	5	7
SCHEMATIC DIAGRAM			
MODEL	AVR347/345		
DESIGN	CHECK	APPROVE	DRAWING NO
M.S.Kim	W.Y.Yang	H.W.Lee	BLOCK DIAGRAM
07.03.14	07.03.14	07.03.14	1190BCDZ

AVR347 Electrical Parts List					
Ref. Designator	Part Number	Description		Qty	
FRONT PCB ASSY (CUP11910-1)					
<i>Capacitors</i>					
C714	HCBS1H151KBT	CAP , CERAMIC	150UF 50V K	1	EA
C716	CCEA1AH331T	CAP , ELECT	330UF 10V	1	EA
C723	HCBS1H104ZFT	CAP , CERAMIC	0.1UF 50V Z	1	EA
C728	HCBS1H104ZFT	CAP , CERAMIC	0.1UF 50V Z	1	EA
C729	HCBS1H473ZFT	CAP , CERAMIC	0.047UF 50V Z	1	EA
C731	CCEA1HH100T	CAP , ELECT	10UF 50V	1	EA
C735	CCEA1CKS100T	CAP , ELECT	10UF 16V	1	EA
C742	HCBS1H223ZFT	CAP , CERAMIC	0.02UF 50V Z	1	EA
C793	HCBS1H104ZFT	CAP , CERAMIC	0.1UF 50V Z	1	EA
C794	HCBS1C222MXT	CAP , CERAMIC	2200PF 16V	1	EA
C795	HCBS1H102KBT	CAP , CERAMIC	1000PF 50V K	1	EA
C796	HCBS1H102KBT	CAP , CERAMIC	1000PF 50V K	1	EA
C882	HCBS1H104ZFT	CAP , CERAMIC	0.1UF 50V Z	1	EA
C891	HCBS1H223ZFT	CAP , CERAMIC	0.023UF 50V Z	1	EA
C892	HCBS1H223ZFT	CAP , CERAMIC	0.023UF 50V Z	1	EA
C893	HCBS1H223ZFT	CAP , CERAMIC	0.023UF 50V Z	1	EA
C894	CCEA1CKS100T	CAP , ELECT	10UF 16V	1	EA
C896	HCBS1H223ZFT	CAP , CERAMIC	0.023UF 50V Z	1	EA
C897	CCEA1AH471T	CAP , ELECT	470UF 10V	1	EA
C901	HCBS1H390JT	CAP , CERAMIC	39PF 50V Z	1	EA
C903	CCEA1HKS2R2T	CAP , ELECT	2.2UF 50V	1	EA
C905	CCEA1HKS2R2T	CAP , ELECT	2.2UF 50V	1	EA
<i>Semiconductors</i>					
D455	CVD1SS133MT	DIODE	1SS133	1	EA
D730	CVD1SS133MT	DIODE	1SS133	1	EA
D778	HVD1N5819T	DIODE , SCHOTTKY	1N5819	1	EA
L702	HLQ02C100KT	COIL , AXAIL	10uH	1	EA
Q701	HVTKRC107MT	TRANSISTOR NPN	KRC107M	1	EA
Q722	HVTKRA107MT	TRANSISTOR NPN	KRA107M	1	EA
Q724	HVTKRC107MT	TRANSISTOR NPN	KRC107M	1	EA
Q725	HVTKRC107MT	TRANSISTOR NPN	KRC107M	1	EA
Q738	HVTKRC107MT	TRANSISTOR NPN	KRC107M	1	EA
Q739	HVTKTA1271YT	TRANSISTOR PNP	KTA1271Y	1	EA
IC73	HRVNJL34H380A	SENSOR , REMOTE	JRC	1	EA
IC75	HVI74ACT04MTR	I.C , HEX INVERTER	FAIRCHILD	1	EA
<i>Resistors</i>					
R701	CRD20TJ103T	RES , CARBON	10K OHM 1/5W J	1	EA
R704	CRD20TJ100T	RES , CARBON	10 OHM 1/5W J	1	EA
R709	CRD20TJ470T	RES , CARBON	47 OHM 1/5W J	1	EA
R710	CRD20TJ470T	RES , CARBON	47 OHM 1/5W J	1	EA
R711	CRD20TJ470T	RES , CARBON	47 OHM 1/5W J	1	EA
R718	CRD20TJ222T	RES , CARBON	2.2K OHM 1/5W J	1	EA
R737	CRD20TJ100T	RES , CARBON	10 OHM 1/5W J	1	EA
R747	CRD20TJ103T	RES , CARBON	10K OHM 1/5W J	1	EA
R781	CRD20TJ102T	RES , CARBON	1K OHM 1/5W J	1	EA
R782	CRD20TJ103T	RES , CARBON	10K OHM 1/5W J	1	EA
R783	CRD20TJ102T	RES , CARBON	1K OHM 1/5W J	1	EA
R784	CRD20TJ102T	RES , CARBON	1K OHM 1/5W J	1	EA
R786	CRD20TJ152T	RES , CARBON	1.5K OHM 1/5W J	1	EA
R787	CRD20TJ101T	RES , CARBON	100 OHM 1/5W J	1	EA
R791	CRD20TJ822T	RES , CARBON	8.2K OHM 1/5W J	1	EA
R892	CRD20TJ222T	RES , CARBON	2.2K OHM 1/5W J	1	EA

Ref. Designator	Part Number	Description		Qty	
FRONT PCB ASSY (CUP11910-1)					
R893	CRD20TJ333T	RES , CARBON	33K OHM 1/5W J	1	EA
R895	CRD20TJ101T	RES , CARBON	100 OHM 1/5W J	1	EA
R920	CRD20TJ102T	RES , CARBON	1K OHM 1/5W J	1	EA
<i>Miscellaneous</i>					
FIP1	HFLHCA18ML03	F.I.P	F.I.P	1	EA
BK71	CMD1A209	BRACKET , FLT	BRACKET	1	EA
BK72	CMD1A209	BRACKET , FLT	BRACKET	1	EA
BK73	CMD1A209	BRACKET , FLT	BRACKET	1	EA
BN81	CWB2C908200BM	WIRE ASS'Y	WIRE	1	EA
BN84	CWB2B905080EN	WIRE ASS'Y	WIRE	1	EA
BN85	CWB2B903100EW	WIRE ASS'Y	WIRE	1	EA
BN88	CWB2B904100EN	WIRE ASS'Y	WIRE	1	EA
BN89	CWB2B904100EN	WIRE ASS'Y	WIRE	1	EA
CN47	CJP07GA117ZY	TEMP ITEM	WAFER	1	EA
CN72	CJP17GA193ZY	WAFER, CARD CABLE (SMD)	WAFER	1	EA
ET03	CMD1A569	BRACKET , PCB	BRACKET	1	EA
RL45	CSL4A014ZE	RELAY (+12V)	AXICOM	1	EA
	CMC3A111	PLATE , EARTH	PLATE	1	EA
	CMD1A618	BRACKET , RESET	BRACKET	1	EA
FRONT STAND BY PCB (CUP11910-3)					
CN88	CJP04GB46ZY	WAFER	WAFER	1	EA
R824	CRD20TJ221T	RES , CARBON	220 OHM 1/5W J	1	EA
R825	CRD20TJ681T	RES , CARBON	680 OHM 1/5W J	1	EA
R828	CRD20TJ221T	RES , CARBON	220 OHM 1/5W J	1	EA
R829	CRD20TJ681T	RES , CARBON	680 OHM 1/5W J	1	EA
S701	HST1A020ZT	SW , TACT	1A020	1	EA
D723	CVD50BOBBWGA	L.E.D , 2 COLOR (ORG , BLUE)	L.E.D	1	EA
D727	CVD50BOBBWGA	L.E.D , 2 COLOR (ORG , BLUE)	L.E.D	1	EA
FRONT POWER PCB (CUP11910-4)					
CN86	CJP02GA89ZM	WAFER	WAFER	1	EA
SW1	CSH1A008ZV	SW , PUSH (MOMS)	MOMS SW	1	EA
DOWNLOAD PCB (CUP11910-7)					
BN80	CWB2B903180EN	WIRE ASS'Y	WIRE	1	EA
IC97	HVIST202EBW	IC , RS232C TRANSCEIVER	ST	1	EA
SW95	KST1A010Z	SW , TACT	1A010	1	EA
SW96	HSH2B018Z	SW , PUSH	SWITCH	1	EA
SW97	HSH2B018Z	SW , PUSH	SWITCH	1	EA
R956	CRD20TJ1R0T	RES , CARBON	1 OHM 1/5W J	1	EA
C953	HCBS1H104ZFT	CAP , CERAMIC	0.1UF 50V Z	1	EA
C954	HCBS1H104ZFT	CAP , CERAMIC	0.1UF 50V Z	1	EA
C957	HCBS1H104ZFT	CAP , CERAMIC	0.1UF 50V Z	1	EA
JK97	CJJ9W001Z	9P D-SUB FEMALE(RS-232C) SEMCO	JACK	1	EA
PCB , FRONT PANEL KEY (CUP11818-2)					
<i>Capacitors</i>					
C719	HCBS1H102KBT	CAP , CERAMIC	1000PF 50V K	1	EA
C720	HCBS1H102KBT	CAP , CERAMIC	1000PF 50V K	1	EA
C721	HCBS1H102KBT	CAP , CERAMIC	1000PF 50V K	1	EA

Ref. Designator	Part Number	Description		Qty	
PCB , FRONT PANEL KEY (CUP11818-2)					
<i>Resistors</i>					
R753	CRD20TF1001T	RES , CARBON	1K /1/5W /F	1	EA
R754	CRD20TF1501T	RES , CARBON	1.5K /1/5W /F	1	EA
R755	CRD20TF1801T	RES , CARBON	1.8K /1/5W /F	1	EA
R756	CRD20TF2701T	RES , CARBON	2.7K /1/5W/F	1	EA
R757	CRD20TF3301T	RES , CARBON	3.3K /1/5W/F	1	EA
R758	CRD20TF5601T	RES , CARBON	5.6K /1/5W F	1	EA
R759	CRD20TF1001T	RES , CARBON	1K /1/5W /F	1	EA
R760	CRD20TF1501T	RES , CARBON	1.5K /1/5W /F	1	EA
R761	CRD20TF1801T	RES , CARBON	1.8K /1/5W /F	1	EA
R762	CRD20TF2701T	RES , CARBON	2.7K /1/5W/F	1	EA
R763	CRD20TF3301T	RES , CARBON	3.3K /1/5W/F	1	EA
R764	CRD20TF5601T	RES , CARBON	5.6K/1/5W/F	1	EA
R765	CRD20TF7501T	RES , CARBON	7.5K/1/5W/F	1	EA
R766	CRD20TF1001T	RES , CARBON	1K /1/5W /F	1	EA
R767	CRD20TF1501T	RES , CARBON	1.5K /1/5W /F	1	EA
R768	CRD20TF1801T	RES , CARBON	1.8K /1/5W /F	1	EA
R769	CRD20TF2701T	RES , CARBON	2.7K /1/5W/F	1	EA
<i>Miscellaneous</i>					
S702	HST1A020ZT	SW , TACT	1A020	1	EA
S703	HST1A020ZT	SW , TACT	1A020	1	EA
S704	HST1A020ZT	SW , TACT	1A020	1	EA
S705	HST1A020ZT	SW , TACT	1A020	1	EA
S706	HST1A020ZT	SW , TACT	1A020	1	EA
S707	HST1A020ZT	SW , TACT	1A020	1	EA
S708	HST1A020ZT	SW , TACT	1A020	1	EA
S709	HST1A020ZT	SW , TACT	1A020	1	EA
S710	HST1A020ZT	SW , TACT	1A020	1	EA
S711	HST1A020ZT	SW , TACT	1A020	1	EA
S712	HST1A020ZT	SW , TACT	1A020	1	EA
S713	HST1A020ZT	SW , TACT	1A020	1	EA
S714	HST1A020ZT	SW , TACT	1A020	1	EA
S715	HST1A020ZT	SW , TACT	1A020	1	EA
S716	HST1A020ZT	SW , TACT	1A020	1	EA
S717	HST1A020ZT	SW , TACT	1A020	1	EA
S718	HST1A020ZT	SW , TACT	1A020	1	EA
S719	HST1A020ZT	SW , TACT	1A020	1	EA
S720	HST1A020ZT	SW , TACT	1A020	1	EA
CN89	CJP04GB46ZY	WAFER	WAFER	1	EA
PCB , HEADPHONE (CUP11910-5)					
<i>Capacitors</i>					
C807	HCBS1H104ZFT	CAP , CERAMIC	0.1UF 50V Z	1	EA
C808	HCBS1H181KBT	CAP , CERAMIC	180PF 50V	1	EA
C809	CCEA1AH471T	CAP , ELECT	470PF 10V	1	EA
C812	HCBS1H104ZFT	CAP , CERAMIC	0.1UF 50V Z	1	EA
C817	HCBS1H100JCT	CAP , CERAMIC	10PF 50V	1	EA
C850	HCBS1H471KBT	CAP , CERAMIC	470PF 50V	1	EA
C851	HCBS1H471KBT	CAP , CERAMIC	470PF 50V	1	EA
C852	HCBS1H104ZFT	CAP , CERAMIC	0.1UF 50V Z	1	EA
C866	CCEA1HKS100T	CAP , ELECT	10UF 50V	1	EA
C867	CCEA1HKS100T	CAP , ELECT	10UF 50V	1	EA
C868	CCEA1EKS470T	CAP , ELECT	47UF 25V	1	EA
C869	CCEA1EKS470T	CAP , ELECT	47UF 25V	1	EA
C870	HCBS1H681KBT	CAP , CERAMIC	680PF 50V K	1	EA
C871	HCBS1H681KBT	CAP , CERAMIC	680PF 50V K	1	EA

Ref. Designator	Part Number	Description		Qty	
PCB , HEADPHONE (CUP11910-5)					
C872	CCEA1CH331T	CAP , ELECT	330UF 16V	1	EA
C873	CCEA1CH331T	CAP , ELECT	330UF 16V	1	EA
C889	HCBS1H104ZFT	CAP , CERAMIC	0.1UF 50V Z	1	EA
<i>Semiconductors</i>					
D784	CVD1SS133MT	DIODE	1SS133	1	EA
D785	CVD1SS133MT	DIODE	1SS133	1	EA
IC76	HVI74HCU04AFNG	I.C , HEX INVERTER	TOSHICA	1	EA
IC86	HVINJM4556AL	I.C , DUAL OP AMP	JRC	1	EA
Q451	HVTKRC107MT	TRANSISTOR NPN	KRC107M	1	EA
Q452	HVTKRA107MT	TRANSISTOR PNP	KRA107M	1	EA
Q454	HVTKRC107MT	TRANSISTOR NPN	KRC107M	1	EA
Q734	HVTKTC2874BT	TRANSISTOR , MUTE NPN	KTC2874B	1	EA
Q735	HVTKTC2874BT	TRANSISTOR , MUTE NPN	KTC2874B	1	EA
Q736	HVTKTC2874BT	TRANSISTOR , MUTE NPN	KTC2874B	1	EA
Q737	HVTKTC2874BT	TRANSISTOR , MUTE NPN	KTC2874B	1	EA
<i>Resistors</i>					
R452	CRD20TJ103T	RES , CARBON	10K OHM 1/5W J	1	EA
R453	CRD20TJ362T	RES , CARBON	3.6K OHM 1/5W J	1	EA
R454	CRD20TJ102T	RES , CARBON	1K OHM 1/5W J	1	EA
R805	CRD20TJ104T	RES , CARBON	100K OHM 1/5W J	1	EA
R806	CRD20TJ472T	RES , CARBON	4.7K OHM 1/5W J	1	EA
R869	CRD20TJ750T	RES , CARBON	75 OHM 1/5W J	1	EA
R896	CRD20TJ101T	RES , CARBON	100 OHM 1/5W J	1	EA
R897	CRD20TJ101T	RES , CARBON	100 OHM 1/5W J	1	EA
R898	CRD20TJ101T	RES , CARBON	100 OHM 1/5W J	1	EA
R899	CRD20TJ104T	RES , CARBON	100K OHM 1/5W J	1	EA
R900	CRD20TJ104T	RES , CARBON	100K OHM 1/5W J	1	EA
R901	CRD20TJ152T	RES , CARBON	1.5K OHM 1/5W J	1	EA
R902	CRD20TJ152T	RES , CARBON	1.5K OHM 1/5W J	1	EA
R903	CRD20TJ102T	RES , CARBON	1K OHM 1/5W J	1	EA
R904	CRD20TJ102T	RES , CARBON	1K OHM 1/5W J	1	EA
R905	CRD20TJ104T	RES , CARBON	100K OHM 1/5W J	1	EA
R906	CRD20TJ104T	RES , CARBON	100K OHM 1/5W J	1	EA
R907	CRD20TJ472T	RES , CARBON	4.7K OHM 1/5W J	1	EA
R908	CRD20TJ472T	RES , CARBON	4.7K OHM 1/5W J	1	EA
R909	CRD20TJ221T	RES , CARBON	220 OHM 1/5W J	1	EA
R910	CRD20TJ221T	RES , CARBON	220 OHM 1/5W J	1	EA
R911	CRD20TJ221T	RES , CARBON	220 OHM 1/5W J	1	EA
R912	CRD20TJ221T	RES , CARBON	220 OHM 1/5W J	1	EA
R913	CRD20TJ102T	RES , CARBON	1K OHM 1/5W J	1	EA
R915	CRD20TJ473T	RES , CARBON	47K OHM 1/5W J	1	EA
R918	CRD20TJ472T	RES , CARBON	4.7K OHM 1/5W J	1	EA
R919	CRD20TJ472T	RES , CARBON	4.7K OHM 1/5W J	1	EA
<i>Miscellaneous</i>					
CN85	CJP03GA19ZY	WAFER, STRAIGHT, 3PIN	WAFER	1	EA
CN92	CJP05GA19ZY	WAFER, STRAIGHT, 5PIN	WAFER	1	EA
BN18	CWZAVR125BN18	WIRE ASS'Y (SHIELD)	WIRE	1	EA
BN22	CWZAVR145BN22	WIRE ASS'Y (SHIELD)	WIRE	1	EA
JK81	CJJ4M043Y	JACK , BOARD	JACK	1	EA
JK82	HJSTORX177L	MODULE , OPTICAL(RX)	OPT JACK(RX)	1	EA
JK83	CJJ2E026Z	JACK , HEADPHONE(SILVER PLATE)	JACK	1	EA
JW82	CWE8202300RV	WIRE ASS'Y	WIRE	1	EA
JW83	CWE8202150RV	WIRE ASS'Y	WIRE	1	EA

Ref. Designator	Part Number	Description		Qty	
PCB , DIGITAL INPUT (CUP11916-1)					
BN17	KJP12GB143ZP	DIP SOCKET	DIP SOCKET	1	EA
C750	CCEA1CH101T	CAP , ELECT	100UF 16V	1	EA
C751	CCEA1CH101T	CAP , ELECT	100UF 16V	1	EA
C752	CCEA1CH101T	CAP , ELECT	100UF 16V	1	EA
C753	HCBS1H181KBT	CAP , CERAMIC	180PF 50V	1	EA
C754	HCBS1H181KBT	CAP , CERAMIC	180PF 50V	1	EA
C755	HCBS1H181KBT	CAP , CERAMIC	180PF 50V	1	EA
C756	CCFT1H104ZF	CAP , SEMICONDUCTOR	0.1UF 50V ZF	1	EA
C757	CCFT1H104ZF	CAP , SEMICONDUCTOR	0.1UF 50V ZF	1	EA
C758	CCFT1H104ZF	CAP , SEMICONDUCTOR	0.1UF 50V ZF	1	EA
C759	HCBS1H101KBT	CAP , CERAMIC	100PF 50V	1	EA
C762	CCEA1CH101T	CAP , ELECT	100UF 16V	1	EA
C763	CCFT1H104ZF	CAP , SEMICONDUCTOR	0.1UF 50V ZF	1	EA
R750	CRD20TJ103T	RES , CARBON	10K OHM 1/5W J	1	EA
R751	CRD20TJ103T	RES , CARBON	10K OHM 1/5W J	1	EA
R752	CRD20TJ103T	RES , CARBON	10K OHM 1/5W J	1	EA
R756	CRD20TJ750T	RES , CARBON	75 OHM 1/5W J	1	EA
R757	CRD20TJ750T	RES , CARBON	75 OHM 1/5W J	1	EA
R758	CRD20TJ750T	RES , CARBON	75 OHM 1/5W J	1	EA
R759	CRD20TJ100T	RES , CARBON	10 OHM 1/5W J	1	EA
R760	CRD20TJ241T	RES , CARBON	240OHM 1/5W J	1	EA
R761	CRD20TJ750T	RES , CARBON	75 OHM 1/5W J	1	EA
JK74	HJSTOTX177L	MODULE , OPTICAL(TX)	OPT JACK(TX)	1	EA
JK75	HJSTORX177L	MODULE , OPTICAL(RX)	OPT JACK(RX)	1	EA
JK76	HJSTORX177L	MODULE , OPTICAL(RX)	OPT JACK(RX)	1	EA
JK77	HJSTORX177L	MODULE , OPTICAL(RX)	OPT JACK(RX)	1	EA
JK78	CJJ4N068Z	JACK , BOARD	JACK	1	EA
JK79	CJJ4N068Z	JACK , BOARD	JACK	1	EA
PCB , VOLUME ENCODER (CUP11910-6)					
<i>Capacitors</i>					
C805	HCBS1H223ZFT	CAP , CERAMIC	0.022UF 50V Z	1	EA
C806	HCBS1H223ZFT	CAP , CERAMIC	0.022UF 50V Z	1	EA
C820	CCEA1HH100T	CAP , ELECT	10UF 50V	1	EA
C821	CCEA1EH470T	CAP , ELECT	47UF 25V	1	EA
C822	CCEA1EH470T	CAP , ELECT	47UF 25V	1	EA
C823	CCEA1HH100T	CAP , ELECT	10UF 50V	1	EA
C824	HCBS1H471KBT	CAP , CERAMIC	470PF 50V	1	EA
C825	HCBS1H151KBT	CAP , CERAMIC	150PF 50V	1	EA
C828	HCBS1H470JT	CAP , CERAMIC	47PF 50V	1	EA
C830	HCBS1H473ZFT	CAP , CERAMIC	0.047F 50V	1	EA
C841	CCEA1HH100T	CAP , ELECT	10UF 50V	1	EA
C842	CCEA1HH100T	CAP , ELECT	10UF 50V	1	EA
C843	CCEA1HH100T	CAP , ELECT	10UF 50V	1	EA
C855	HCBS1H101KBT	CAP , CERAMIC	100PF 50V K	1	EA
C856	HCBS1H101KBT	CAP , CERAMIC	100PF 50V K	1	EA
C857	HCBS1H104ZFT	CAP , CERAMIC	0.1UF 50V Z	1	EA
C862	HCBS1H101KBT	CAP , CERAMIC	100PF 50V K	1	EA
C863	HCBS1H101KBT	CAP , CERAMIC	100PF 50V K	1	EA
C874	HCBS1H101KBT	CAP , CERAMIC	100PF 50V K	1	EA
C402	CCEA1HH100T	CAP , ELECT	10UF 50V	1	EA
C403	CCEA1HH100T	CAP , ELECT	10UF 50V	1	EA
<i>Semiconductors</i>					
IC41	CVINJU7301M	I.C , C-MOS SPST ANALOG SWITCH	JRC	1	EA
IC87	HVINJM2068MDTE1	I.C , DUAL OP AMP	JRC	1	EA
Q401	HVTKRC104MT	TRANSISTOR PNP	KRC104M	1	EA
D701	CVD52CSBBCEAB2	BLUE L.E.D	L.E.D	1	EA

Ref. Designator	Part Number	Description		Qty	
PCB , VOLUME ENCODER (CUP11910-6)					
D703	CVD52CSBBCEAB2	BLUE L.E.D	L.E.D	1	EA
D705	CVD52CSBBCEAB2	BLUE L.E.D	L.E.D	1	EA
D774	CVD1SS133MT	DIODE	1SS133	1	EA
<i>Resistors</i>					
J906	CRD20TJ391T	RES , CARBON	390OHM 1/5W	1	EA
R402	CRD20TJ101T	RES , CARBON	100 OHM 1/5W J	1	EA
R403	CRD20TJ104T	RES , CARBON	100K OHM 1/5W J	1	EA
R404	CRD20TJ101T	RES , CARBON	100 OHM 1/5W J	1	EA
R705	CRD20TJ820T	RES , CARBON	82 OHM 1/5W J	1	EA
R706	CRD20TJ820T	RES , CARBON	82 OHM 1/5W J	1	EA
R708	CRD20TJ820T	RES , CARBON	82 OHM 1/5W J	1	EA
R864	CRD20TJ272T	RES , CARBON	2.7K OHM 1/5W J	1	EA
R865	CRD20TJ101T	RES , CARBON	100 OHM 1/5W J	1	EA
R866	CRD20TJ272T	RES , CARBON	2.7K OHM 1/5W J	1	EA
R871	CRD20TJ104T	RES , CARBON	100K OHM 1/5W J	1	EA
R872	CRD20TJ104T	RES , CARBON	100K OHM 1/5W J	1	EA
R873	CRD20TJ471T	RES , CARBON	470 OHM 1/5W J	1	EA
R874	CRD20TJ471T	RES , CARBON	470 OHM 1/5W J	1	EA
R875	CRD20TJ103T	RES , CARBON	10K OHM 1/5W J	1	EA
R876	CRD20TJ750T	RES , CARBON	75 OHM 1/5W J	1	EA
R877	CRD20TJ750T	RES , CARBON	75 OHM 1/5W J	1	EA
R878	CRD20TJ750T	RES , CARBON	75 OHM 1/5W J	1	EA
R921	CRD20TJ103T	RES , CARBON	10K OHM 1/5W J	1	EA
R922	CRD20TJ102T	RES , CARBON	1K OHM 1/5W J	1	EA
R923	CRD20TJ101T	RES , CARBON	100 OHM 1/5W J	1	EA
R924	CRD20TJ101T	RES , CARBON	100 OHM 1/5W J	1	EA
R926	CRD20TJ103T	RES , CARBON	10K OHM 1/5W J	1	EA
R931	CRD20TJ104T	RES , CARBON	100K OHM 1/5W J	1	EA
R934	CRD20TJ222T	RES , CARBON	2.2K OHM 1/5W J	1	EA
R935	CRD20TJ103T	RES , CARBON	10K OHM 1/5W J	1	EA
R936	CRD20TJ152T	RES , CARBON	1.5K OHM 1/5W J	1	EA
R937	CRD20TJ104T	RES , CARBON	100K OHM 1/5W J	1	EA
VR74	CSR2A037Z	ENCODER	ENCODER	1	EA
<i>Miscellaneous</i>					
CN84	CJP05GB46ZY	WAFER	WAFER	1	EA
BN10	CWZAVR230BN10	WIRE ASS'Y (SHIELD)	WIRE	1	EA
BN41	CWZAVR130BN41	WIRE ASS'Y (SHIELD)	WIRE	1	EA
BN92	CWB2B905100EN	WIRE ASS'Y	WIRE	1	EA
JK85	CJJ9M003Z	JACK , S-VIDEO	JACK	1	EA
JK86	CJJ4S023Y	JACK , BOARD	JACK	1	EA
JW84	CWE8202110RV	WIRE ASS'Y	WIRE	1	EA
INPUT PCB (CUP11913-1)					
<i>Capacitors</i>					
C201	CCUS1H221JA	CAP , CHIP	220PF	1	EA
C202	CCUS1H221JA	CAP , CHIP	220PF	1	EA
C203	CCUS1H221JA	CAP , CHIP	220PF	1	EA
C204	CCUS1H221JA	CAP , CHIP	220PF	1	EA
C205	CCUS1H221JA	CAP , CHIP	220PF	1	EA
C206	CCUS1H221JA	CAP , CHIP	220PF	1	EA
C207	CCUS1H221JA	CAP , CHIP	220PF	1	EA
C208	CCUS1H221JA	CAP , CHIP	220PF	1	EA
C209	CCUS1H221JA	CAP , CHIP	220PF	1	EA
C210	CCUS1H221JA	CAP , CHIP	220PF	1	EA
C211	CCUS1H221JA	CAP , CHIP	220PF	1	EA

Ref. Designator	Part Number	Description		Qty	
INPUT PCB (CUP11913-1)					
C212	CCUS1H221JA	CAP , CHIP	220PF	1	EA
C213	CCUS1H221JA	CAP , CHIP	220PF	1	EA
C214	CCUS1H221JA	CAP , CHIP	220PF	1	EA
C215	CCUS1H221JA	CAP , CHIP	220PF	1	EA
C216	CCUS1H221JA	CAP , CHIP	220PF	1	EA
C219	CCUS1H221JA	CAP , CHIP	220PF	1	EA
C220	CCUS1H221JA	CAP , CHIP	220PF	1	EA
C221	CCUS1H221JA	CAP , CHIP	220PF	1	EA
C222	CCUS1H221JA	CAP , CHIP	220PF	1	EA
C223	CCUS1H221JA	CAP , CHIP	220PF	1	EA
C224	CCUS1H221JA	CAP , CHIP	220PF	1	EA
C225	CCUS1H221JA	CAP , CHIP	220PF	1	EA
C226	CCUS1H221JA	CAP , CHIP	220PF	1	EA
C260	CCUS1H104KC	CAP , CHIP	0.1UF	1	EA
C269	CCUS1A105KC	CAP , CHIP	1UF	1	EA
C274	CCUS1A105KC	CAP , CHIP	1UF	1	EA
C277	CCUS1H104KC	CAP , CHIP	0.1UF	1	EA
C278	CCUS1H104KC	CAP , CHIP	0.1UF	1	EA
C279	CCUS1H104KC	CAP , CHIP	0.1UF	1	EA
C280	CCUS1H104KC	CAP , CHIP	0.1UF	1	EA
C289	CCUS1H104KC	CAP , CHIP	0.1UF	1	EA
C290	CCUS1H104KC	CAP , CHIP	0.1UF	1	EA
C291	CCUS1H104KC	CAP , CHIP	0.1UF	1	EA
C293	CCUS1H104KC	CAP , CHIP	0.1UF	1	EA
C295	CCUS1H272KC	CAP , CHIP	2700PF	1	EA
C296	CCUS1H272KC	CAP , CHIP	2700PF	1	EA
C299	CCUS1H104KC	CAP , CHIP	0.1UF	1	EA
C301	CCUS1H152KC	CAP , CHIP	1500PF	1	EA
C302	CCUS1H152KC	CAP , CHIP	1500PF	1	EA
C303	CCUS1H152KC	CAP , CHIP	1500PF	1	EA
C304	CCUS1H152KC	CAP , CHIP	1500PF	1	EA
C305	CCUS1H152KC	CAP , CHIP	1500PF	1	EA
C306	CCUS1H152KC	CAP , CHIP	1500PF	1	EA
C307	CCUS1H152KC	CAP , CHIP	1500PF	1	EA
C308	CCUS1H152KC	CAP , CHIP	1500PF	1	EA
C309	CCUS1H102KC	CAP , CHIP	1000PF	1	EA
C310	CCUS1H102KC	CAP , CHIP	1000PF	1	EA
C311	CCUS1H102KC	CAP , CHIP	1000PF	1	EA
C312	CCUS1H102KC	CAP , CHIP	1000PF	1	EA
C313	CCUS1H102KC	CAP , CHIP	1000PF	1	EA
C314	CCUS1H102KC	CAP , CHIP	1000PF	1	EA
C315	CCUS1H102KC	CAP , CHIP	1000PF	1	EA
C316	CCUS1H102KC	CAP , CHIP	1000PF	1	EA
C317	CCUS1H223KC	CAP , CHIP	0.022UF	1	EA
C318	CCUS1H223KC	CAP , CHIP	0.022UF	1	EA
C319	CCUS1H223KC	CAP , CHIP	0.022UF	1	EA
C320	CCUS1H223KC	CAP , CHIP	0.022UF	1	EA
C321	CCUS1H681JA	CAP , CHIP	680PF	1	EA
C322	CCUS1H681JA	CAP , CHIP	680PF	1	EA
C323	CCUS1H681JA	CAP , CHIP	680PF	1	EA
C324	CCUS1H681JA	CAP , CHIP	680PF	1	EA
C325	CCUS1H681JA	CAP , CHIP	680PF	1	EA
C326	CCUS1H681JA	CAP , CHIP	680PF	1	EA
C327	CCUS1H681JA	CAP , CHIP	680PF	1	EA
C328	CCUS1H681JA	CAP , CHIP	680PF	1	EA
C329	CCUS1H681JA	CAP , CHIP	680PF	1	EA
C330	CCUS1H681JA	CAP , CHIP	680PF	1	EA
C331	CCUS1H681JA	CAP , CHIP	680PF	1	EA
C332	CCUS1H681JA	CAP , CHIP	680PF	1	EA
C333	CCUS1H681JA	CAP , CHIP	680PF	1	EA
C334	CCUS1H681JA	CAP , CHIP	680PF	1	EA

Ref. Designator	Part Number	Description		Qty	
INPUT PCB (CUP11913-1)					
C335	CCUS1H681JA	CAP , CHIP	680PF	1	EA
C336	CCUS1H681JA	CAP , CHIP	680PF	1	EA
C337	CCUS1H223KC	CAP , CHIP	0.022UF	1	EA
C338	CCUS1H223KC	CAP , CHIP	0.022UF	1	EA
C339	CCUS1H223KC	CAP , CHIP	0.022UF	1	EA
C340	CCUS1H223KC	CAP , CHIP	0.022UF	1	EA
C350	CCUS1H102KC	CAP , CHIP	1000PF	1	EA
C351	CCUS1H102KC	CAP , CHIP	1000PF	1	EA
C352	CCUS1H102KC	CAP , CHIP	1000PF	1	EA
C353	CCUS1H102KC	CAP , CHIP	1000PF	1	EA
C354	CCUS1H102KC	CAP , CHIP	1000PF	1	EA
C355	CCUS1H102KC	CAP , CHIP	1000PF	1	EA
C356	CCUS1H102KC	CAP , CHIP	1000PF	1	EA
C357	CCUS1H102KC	CAP , CHIP	1000PF	1	EA
C369	CCUS1H223KC	CAP , CHIP	0.022UF	1	EA
C370	CCUS1H223KC	CAP , CHIP	0.022UF	1	EA
C381	CCUS1H223KC	CAP , CHIP	0.022UF	1	EA
C382	CCUS1H223KC	CAP , CHIP	0.022UF	1	EA
C383	CCUS1H223KC	CAP , CHIP	0.022UF	1	EA
C384	CCUS1H223KC	CAP , CHIP	0.022UF	1	EA
C385	CCUS1H223KC	CAP , CHIP	0.022UF	1	EA
C386	CCUS1H223KC	CAP , CHIP	0.022UF	1	EA
C387	CCUS1H223KC	CAP , CHIP	0.022UF	1	EA
C388	CCUS1H223KC	CAP , CHIP	0.022UF	1	EA
C391	CCUS1H151JA	CAP , CHIP	150PF	1	EA
C392	CCUS1H151JA	CAP , CHIP	150PF	1	EA
C393	CCUS1H151JA	CAP , CHIP	150PF	1	EA
C394	CCUS1H102KC	CAP , CHIP	1000PF	1	EA
C395	CCUS1H151JA	CAP , CHIP	150PF	1	EA
C396	CCUS1H151JA	CAP , CHIP	150PF	1	EA
C397	CCUS1H151JA	CAP , CHIP	150PF	1	EA
C398	CCUS1H151JA	CAP , CHIP	150PF	1	EA
C402	CCUS1H471JA	CAP , CHIP	470PF	1	EA
C403	CCUS1H471JA	CAP , CHIP	470PF	1	EA
C532	CCUS1H182KC	CAP , CHIP	1800PF	1	EA
C534	CCUS1H182KC	CAP , CHIP	1800PF	1	EA
C535	CCUS1H182KC	CAP , CHIP	1800PF	1	EA
C536	CCUS1H182KC	CAP , CHIP	1800PF	1	EA
C537	CCUS1H182KC	CAP , CHIP	1800PF	1	EA
C538	CCUS1H182KC	CAP , CHIP	1800PF	1	EA
C539	CCUS1H182KC	CAP , CHIP	1800PF	1	EA
C540	CCUS1H182KC	CAP , CHIP	1800PF	1	EA
C601	CCUS1H104KC	CAP , CHIP	0.1UF	1	EA
C603	CCUS1H104KC	CAP , CHIP	0.1UF	1	EA
C605	CCUS1H104KC	CAP , CHIP	0.1UF	1	EA
C607	CCUS1H104KC	CAP , CHIP	0.1UF	1	EA
C609	CCUS1H104KC	CAP , CHIP	0.1UF	1	EA
C611	CCUS1H104KC	CAP , CHIP	0.1UF	1	EA
C613	CCUS1H104KC	CAP , CHIP	0.1UF	1	EA
C615	CCUS1H104KC	CAP , CHIP	0.1UF	1	EA
C617	CCUS1H104KC	CAP , CHIP	0.1UF	1	EA
C619	CCUS1H104KC	CAP , CHIP	0.1UF	1	EA
C621	CCUS1H104KC	CAP , CHIP	0.1UF	1	EA
C623	CCUS1H104KC	CAP , CHIP	0.1UF	1	EA
C625	CCUS1H104KC	CAP , CHIP	0.1UF	1	EA
C627	CCUS1H104KC	CAP , CHIP	0.1UF	1	EA
C629	CCUS1H104KC	CAP , CHIP	0.1UF	1	EA
C631	CCUS1H104KC	CAP , CHIP	0.1UF	1	EA
C701	CCUS1H150JA	CAP , CHIP	15PF	1	EA
C702	CCUS1H150JA	CAP , CHIP	15PF	1	EA
C704	CCUS1H104KC	CAP , CHIP	0.1UF	1	EA

Ref. Designator	Part Number	Description		Qty	
INPUT PCB (CUP11913-1)					
C705	CCUS1H104KC	CAP , CHIP	0.1UF	1	EA
C707	CCUS1H102KC	CAP , CHIP	1000PF	1	EA
C708	CCUS1H104KC	CAP , CHIP	0.1UF	1	EA
C716	CCUS1H151JA	CAP , CHIP	150PF	1	EA
C718	CCUS1H104KC	CAP , CHIP	0.1UF	1	EA
C719	CCUS1H104KC	CAP , CHIP	0.1UF	1	EA
C722	CCUS1H104KC	CAP , CHIP	0.1UF	1	EA
C723	CCUS1H473KC	CAP , CHIP	0.047UF	1	EA
C725	CCUS1H104KC	CAP , CHIP	0.1UF	1	EA
C727	CCUS1H104KC	CAP , CHIP	0.1UF	1	EA
C729	CCUS1H104KC	CAP , CHIP	0.1UF	1	EA
C731	CCUS1H104KC	CAP , CHIP	0.1UF	1	EA
C733	CCUS1H104KC	CAP , CHIP	0.1UF	1	EA
C734	CCUS1H102KC	CAP , CHIP	1000PF	1	EA
C735	CCUS1H470JA	CAP , CHIP	47PF	1	EA
C738	CCUS1A105KC	CAP , CHIP	1UF	1	EA
C739	CCUS1H103KC	CAP , CHIP	0.01UF	1	EA
C741	CCUS1H104KC	CAP , CHIP	0.1UF	1	EA
C742	CCUS1H180JA	CAP , CHIP	18PF	1	EA
C743	CCUS1H104KC	CAP , CHIP	0.1UF	1	EA
C744	CCUS1H180JA	CAP , CHIP	18PF	1	EA
C745	CCUS1H104KC	CAP , CHIP	0.1UF	1	EA
C746	CCUS1H104KC	CAP , CHIP	0.1UF	1	EA
C747	CCUS1H104KC	CAP , CHIP	0.1UF	1	EA
C748	CCUS1H104KC	CAP , CHIP	0.1UF	1	EA
C751	CCUS1H104KC	CAP , CHIP	0.1UF	1	EA
C754	CCUS1H104KC	CAP , CHIP	0.1UF	1	EA
C756	CCUS1H104KC	CAP , CHIP	0.1UF	1	EA
C757	CCUS1H104KC	CAP , CHIP	0.1UF	1	EA
C758	CCUS1H104KC	CAP , CHIP	0.1UF	1	EA
C759	CCUS1H104KC	CAP , CHIP	0.1UF	1	EA
C760	CCUS1H104KC	CAP , CHIP	0.1UF	1	EA
C761	CCUS1H104KC	CAP , CHIP	0.1UF	1	EA
C762	CCUS1H104KC	CAP , CHIP	0.1UF	1	EA
C763	CCUS1H104KC	CAP , CHIP	0.1UF	1	EA
C765	CCUS1H104KC	CAP , CHIP	0.1UF	1	EA
C768	CCUS1H104KC	CAP , CHIP	0.1UF	1	EA
C769	CCUS1H104KC	CAP , CHIP	0.1UF	1	EA
C770	CCUS1H104KC	CAP , CHIP	0.1UF	1	EA
C771	CCUS1H104KC	CAP , CHIP	0.1UF	1	EA
C772	CCUS1H104KC	CAP , CHIP	0.1UF	1	EA
C773	CCUS1H104KC	CAP , CHIP	0.1UF	1	EA
C780	CCUS1H102KC	CAP , CHIP	1000PF	1	EA
C781	CCUS1H223KC	CAP , CHIP	0.022UF	1	EA
C782	CCUS1H103KC	CAP , CHIP	0.01UF	1	EA
C783	CCUS1H103KC	CAP , CHIP	0.01UF	1	EA
C784	CCUS1H103KC	CAP , CHIP	0.01UF	1	EA
C785	CCUS1H103KC	CAP , CHIP	0.01UF	1	EA
C786	CCUS1H103KC	CAP , CHIP	0.01UF	1	EA
C787	CCUS1H103KC	CAP , CHIP	0.01UF	1	EA
C789	CCUS1H103KC	CAP , CHIP	0.01UF	1	EA
C790	CCUS1H103KC	CAP , CHIP	0.01UF	1	EA
C791	CCUS1H104KC	CAP , CHIP	0.1UF	1	EA
C792	CCUS1H104KC	CAP , CHIP	0.1UF	1	EA
C901	CCUS1H223KC	CAP , CHIP	0.022UF	1	EA
C902	CCUS1H223KC	CAP , CHIP	0.022UF	1	EA
C903	CCUS1H223KC	CAP , CHIP	0.022UF	1	EA
C904	CCUS1H223KC	CAP , CHIP	0.022UF	1	EA
C952	CCUS1H223KC	CAP , CHIP	0.022UF	1	EA
C261	CCEA1EH470T	CAP , ELECT	47UF 25V	1	EA
C262	CCEA1EH470T	CAP , ELECT	47UF 25V	1	EA

Ref. Designator	Part Number	Description		Qty	
INPUT PCB (CUP11913-1)					
C263	CCEA1EH470T	CAP , ELECT	47UF 25V	1	EA
C264	CCEA1EH470T	CAP , ELECT	47UF 25V	1	EA
C265	CCEA1EH470T	CAP , ELECT	47UF 25V	1	EA
C266	CCEA1EH470T	CAP , ELECT	47UF 25V	1	EA
C267	CCEA1EH470T	CAP , ELECT	47UF 25V	1	EA
C268	CCEA1EH470T	CAP , ELECT	47UF 25V	1	EA
C270	CCEA1HH100T	CAP , ELECT	10UF 50V	1	EA
C271	CCEA1HH100T	CAP , ELECT	10UF 50V	1	EA
C272	CCEA1HH100T	CAP , ELECT	10UF 50V	1	EA
C273	CCEA1HH100T	CAP , ELECT	10UF 50V	1	EA
C275	CCEA1HH100T	CAP , ELECT	10UF 50V	1	EA
C276	CCEA1HH100T	CAP , ELECT	10UF 50V	1	EA
C281	CCEA1HH100T	CAP , ELECT	10UF 50V	1	EA
C282	CCEA1HH100T	CAP , ELECT	10UF 50V	1	EA
C283	CCEA1HH100T	CAP , ELECT	10UF 50V	1	EA
C284	CCEA1HH100T	CAP , ELECT	10UF 50V	1	EA
C285	CCEA1HH100T	CAP , ELECT	10UF 50V	1	EA
C286	CCEA1HH100T	CAP , ELECT	10UF 50V	1	EA
C287	CCEA1HH100T	CAP , ELECT	10UF 50V	1	EA
C288	CCEA1HH100T	CAP , ELECT	10UF 50V	1	EA
C292	CCEA1CH101T	CAP , ELECT	100UF 16V	1	EA
C294	CCEA1CH101T	CAP , ELECT	100UF 16V	1	EA
C341	CCEA1HH100T	CAP , ELECT	10UF 50V	1	EA
C342	CCEA1HH100T	CAP , ELECT	10UF 50V	1	EA
C343	CCEA1HH100T	CAP , ELECT	10UF 50V	1	EA
C344	CCEA1HH100T	CAP , ELECT	10UF 50V	1	EA
C345	CCEA1HH100T	CAP , ELECT	10UF 50V	1	EA
C346	CCEA1HH100T	CAP , ELECT	10UF 50V	1	EA
C347	CCEA1HH100T	CAP , ELECT	10UF 50V	1	EA
C348	CCEA1HH100T	CAP , ELECT	10UF 50V	1	EA
C349	CCEA1CH101T	CAP , ELECT	100UF 16V	1	EA
C358	CCEA1CH101T	CAP , ELECT	100UF 16V	1	EA
C359	CCEA1CH101T	CAP , ELECT	100UF 16V	1	EA
C360	CCEA1CH101T	CAP , ELECT	100UF 16V	1	EA
C371	CCEA1HH100T	CAP , ELECT	10UF 50V	1	EA
C372	CCEA1HH100T	CAP , ELECT	10UF 50V	1	EA
C373	CCEA1HH100T	CAP , ELECT	10UF 50V	1	EA
C374	CCEA1HH100T	CAP , ELECT	10UF 50V	1	EA
C375	CCEA1HH100T	CAP , ELECT	10UF 50V	1	EA
C376	CCEA1HH100T	CAP , ELECT	10UF 50V	1	EA
C377	CCEA1HH100T	CAP , ELECT	10UF 50V	1	EA
C378	CCEA1HH100T	CAP , ELECT	10UF 50V	1	EA
C389	CCEA1HH100T	CAP , ELECT	10UF 50V	1	EA
C390	CCEA1HH100T	CAP , ELECT	10UF 50V	1	EA
C447	CCEA1HH100T	CAP , ELECT	10UF 50V	1	EA
C600	CCEA1CH101T	CAP , ELECT	100UF 16V	1	EA
C602	CCEA1CH101T	CAP , ELECT	100UF 16V	1	EA
C604	CCEA1CH101T	CAP , ELECT	100UF 16V	1	EA
C606	CCEA1CH101T	CAP , ELECT	100UF 16V	1	EA
C608	CCEA1CH101T	CAP , ELECT	100UF 16V	1	EA
C610	CCEA1CH101T	CAP , ELECT	100UF 16V	1	EA
C612	CCEA1CH101T	CAP , ELECT	100UF 16V	1	EA
C614	CCEA1CH101T	CAP , ELECT	100UF 16V	1	EA
C616	CCEA1CH101T	CAP , ELECT	100UF 16V	1	EA
C618	CCEA1CH101T	CAP , ELECT	100UF 16V	1	EA
C620	CCEA1CH101T	CAP , ELECT	100UF 16V	1	EA
C622	CCEA1CH101T	CAP , ELECT	100UF 16V	1	EA
C624	CCEA1CH101T	CAP , ELECT	100UF 16V	1	EA
C626	CCEA1CH101T	CAP , ELECT	100UF 16V	1	EA
C628	CCEA1CH101T	CAP , ELECT	100UF 16V	1	EA
C630	CCEA1CH101T	CAP , ELECT	100UF 16V	1	EA

Ref. Designator	Part Number	Description		Qty	
INPUT PCB (CUP11913-1)					
C703	CCEA1CH101T	CAP , ELECT	100UF 16V	1	EA
C706	CCEA1CH101T	CAP , ELECT	100UF 16V	1	EA
C715	CCEA1HH4R7T	CAP , ELECT	4.7UF 50V	1	EA
C717	CCEA1HH4R7T	CAP , ELECT	4.7UF 50V	1	EA
C720	CCEA1CH101T	CAP , ELECT	100UF 16V	1	EA
C721	CCEA1AH471T	CAP , ELECT	470UF 10V	1	EA
C724	CCEA1AH471T	CAP , ELECT	470UF 10V	1	EA
C726	CCEA1CH101T	CAP , ELECT	100UF 16V	1	EA
C728	CCEA1AH471T	CAP , ELECT	470UF 10V	1	EA
C730	CCEA1CH101T	CAP , ELECT	100UF 16V	1	EA
C736	CCEA1HH2R2T	CAP , ELECT	2.2UF 50V	1	EA
C737	CCEA1CH101T	CAP , ELECT	100UF 16V	1	EA
C740	CCEA1CH101T	CAP , ELECT	100UF 16V	1	EA
C749	CCEA1CH101T	CAP , ELECT	100UF 16V	1	EA
C750	CCEA1CH101T	CAP , ELECT	100UF 16V	1	EA
C752	CCEA1CH101T	CAP , ELECT	100UF 16V	1	EA
C753	CCEA1CH101T	CAP , ELECT	100UF 16V	1	EA
C764	CCEA0JH102T	CAP , ELECT	1000UF 6.3V	1	EA
C766	CCEA0JH102T	CAP , ELECT	1000UF 6.3V	1	EA
C905	CCEA1CH101T	CAP , ELECT	100UF 16V	1	EA
C906	CCEA1CH101T	CAP , ELECT	100UF 16V	1	EA
C907	CCEA1CH101T	CAP , ELECT	100UF 16V	1	EA
C908	CCEA1CH101T	CAP , ELECT	100UF 16V	1	EA
C910	CCEA1VH221T	CAP , ELECT	220UF 35V	1	EA
C950	CCEA1VH101T	CAP , ELECT	100UF 35V	1	EA
C954	CCEA1VH101T	CAP , ELECT	100UF 35V	1	EA
C955	CCEA1EH221T	CAP , ELECT	220UF 25V	1	EA
C732	CCEA0JKR3222E	CAP , ELECT	2200UF 6.3V	1	EA
C911	CCEA1EH471E	CAP , ELECT	470UF/25V	1	EA
<i>Semiconductors</i>					
D201	HVD1SS355T	DIODE , CHIP	1SS355T	1	EA
D202	HVD1SS355T	DIODE , CHIP	1SS355T	1	EA
D203	HVD1SS355T	DIODE , CHIP	1SS355T	1	EA
D204	HVD1SS355T	DIODE , CHIP	1SS355T	1	EA
D205	HVD1SS355T	DIODE , CHIP	1SS355T	1	EA
D206	HVD1SS355T	DIODE , CHIP	1SS355T	1	EA
D207	HVD1SS355T	DIODE , CHIP	1SS355T	1	EA
D208	HVD1SS355T	DIODE , CHIP	1SS355T	1	EA
D209	HVD1SS355T	DIODE , CHIP	1SS355T	1	EA
D210	HVD1SS355T	DIODE , CHIP	1SS355T	1	EA
D211	HVD1SS355T	DIODE , CHIP	1SS355T	1	EA
D212	HVD1SS355T	DIODE , CHIP	1SS355T	1	EA
D213	HVD1SS355T	DIODE , CHIP	1SS355T	1	EA
D214	HVD1SS355T	DIODE , CHIP	1SS355T	1	EA
D215	HVD1SS355T	DIODE , CHIP	1SS355T	1	EA
D216	HVD1SS355T	DIODE , CHIP	1SS355T	1	EA
D701	HVDRLS4148SR	DIODE, SWITCHING, SMD TYPE	RLS4148 TE-11	1	EA
D725	HVD1SS355T	DIODE , CHIP	1SS355T	1	EA
D727	HVD1SS355T	DIODE , CHIP	1SS355T	1	EA
IC20	CVINJW1197FC2	IC , SW(WITH VOLUME)	JRC	1	EA
IC21	HVINJM2068MDTE1	I.C , DUAL OP AMP	JRC	1	EA
IC22	HVINJM2068MDTE1	I.C , DUAL OP AMP	JRC	1	EA
IC23	HVINJM2068MDTE1	I.C , DUAL OP AMP	JRC	1	EA
IC24	HVINJM2068MDTE1	I.C , DUAL OP AMP	JRC	1	EA
IC25	HVINJM2068MDTE1	I.C , DUAL OP AMP	JRC	1	EA
IC31	HVINJM2068MDTE1	I.C , DUAL OP AMP	JRC	1	EA
IC32	HVINJM2068MDTE1	I.C , DUAL OP AMP	JRC	1	EA
IC33	HVINJM2068MDTE1	I.C , DUAL OP AMP	JRC	1	EA
IC34	HVINJM2068MDTE1	I.C , DUAL OP AMP	JRC	1	EA

Ref. Designator	Part Number	Description		Qty	
INPUT PCB (CUP11913-1)					
IC50	HVINJM2068MDTE1	I.C , DUAL OP AMP	JRC	1	EA
IC70	HVITC74VHC157FT	I.C, 2-CHANNEL MUX	ST	1	EA
IC71	HVITC74VHC157FT	I.C, 2-CHANNEL MUX	ST	1	EA
IC72	HVI74HCU04AFNG	I.C , HEX INVERTER	TOSHIBA	1	EA
IC73	HVICS42528-CQ	I.C , CODEC + DIR	CIRRUS LOGIC	1	EA
IC75	CVICS49510-CQ	I.C , DSP	CIRRUS LOGIC	1	EA
IC76	CVIES29LV800ET70TG	IC , FLASH MEMORY (8Mbit)	EXCELSEMI	1	EA
IC77	HVI57V161610ET7	SDRAM 16M 7NS	HYNIX	1	EA
IC78	HVINJM2391DL133	I.C , CHIP REGULATOR (+3.3V)	JRC	1	EA
IC79	HVILM1117S-1V8	I.C , REGULATOR (1.8V)	HTC	1	EA
IC88	HVILM1117S-3V3	I.C , REGULATOR (3.3V)	HTC	1	EA
IC89	CVIM24C32WMN6TP	I.C , EEPROM (32 Kbit)	ST	1	EA
IC90	CVIT5CC1	I.C , FLASH U-COM	TOSHIBA	1	EA
IC91	HVI74ACT04MTR	I.C , HEX INVERTER	TOSHIBA	1	EA
Q729	HVTKRC107S	TRANSISTOR , CHIP NPN	KRC107S	1	EA
Q730	HVTKRC107S	TRANSISTOR , CHIP NPN	KRC107S	1	EA
Q732	HVTKRC107S	TRANSISTOR , CHIP NPN	KRC107S	1	EA
Q734	HVTKRC107S	TRANSISTOR , CHIP NPN	KRC107S	1	EA
Q735	HVTKRA107S	TRANSISTOR , CHIP NPN	KRC107S	1	EA
Q736	HVTKRA107S	TRANSISTOR , CHIP NPN	KRC107S	1	EA
D221	CVD1N4003ST	RECT , DIODE	1N4003	1	EA
D222	CVD1N4003ST	RECT , DIODE	1N4003	1	EA
D703	CVD1N4003ST	RECT , DIODE	1N4003	1	EA
D704	CVD1N4003SRT	RECT , DIODE	1N4003	1	EA
D902	HVD1N5819T	DIODE , SCHOTTKY	1N5819	1	EA
D955	CVD1N4003ST	RECT , DIODE	1N4003	1	EA
D956	CVD1N4003ST	RECT , DIODE	1N4003	1	EA
IC87	HVIRE5VL28CATZ	IC , RESET	RICOH	1	EA
Q301	HVTKTC2874BT	TRANSISTOR , NPN, MUTE	KTC2874B	1	EA
Q302	HVTKTC2874BT	TRANSISTOR , NPN, MUTE	KTC2874B	1	EA
Q303	HVTKTC2874BT	TRANSISTOR , NPN, MUTE	KTC2874B	1	EA
Q304	HVTKTC2874BT	TRANSISTOR , NPN, MUTE	KTC2874B	1	EA
Q305	HVTKTC2874BT	TRANSISTOR , NPN, MUTE	KTC2874B	1	EA
Q306	HVTKTC2874BT	TRANSISTOR , NPN, MUTE	KTC2874B	1	EA
Q307	HVTKTC2874BT	TRANSISTOR , NPN, MUTE	KTC2874B	1	EA
Q308	HVTKTC2874BT	TRANSISTOR , NPN, MUTE	KTC2874B	1	EA
Q311	HVTKTC2874BT	TRANSISTOR , NPN, MUTE	KTC2874B	1	EA
Q731	HVTKSA1175YT	TRANSISTOR PNP	KSA1175Y	1	EA
Q733	HVTKSC2785YT	TRANSISTOR NPN	KSC2785Y	1	EA
Q737	HVTKSC2785YT	TRANSISTOR NPN	KSC2785Y	1	EA
IC36	HVIL7808CP	I.C , REGULATOR (+8V)	ST	1	EA
IC37	HVINJM7908FA	I.C, REGULATOR(-8V)	JRC	1	EA
IC92	HVIL7805CP	I.C , REGULATOR (+5V)	ST	1	EA
IC93	HVIL7905CP	I.C , REGULATOR (-5V)	ST	1	EA
IC94	HVIL7805CP	I.C , REGULATOR (+5V)	ST	1	EA
IC95	HVIL7812CP	I.C , REGULATOR (+12V)	ST	1	EA
IC96	HVINJM7824FA	I.C , REGULATOR(+24V)	JRC	1	EA
Resistors					
RN52	CRJ102DJ220T	RES , CHIP NETWORK 1/10W, 22oh	22OHM/1608*4	1	EA
RN61	CRJ104DJ103T	RES , 4ARRAY (1608*4)	10K OHM/1608*4	1	EA
RN62	CRJ104DJ103T	RES , 4ARRAY (1608*4)	10K OHM/1608*4	1	EA
RN63	CRJ104DJ103T	RES , 4ARRAY (1608*4)	10K OHM/1608*4	1	EA
RN64	CRJ104DJ101T	RES , 4ARRAY (1608*4)	100 OHM/1608*4	1	EA
RN65	CRJ104DJ101T	RES , 4ARRAY (1608*4)	100 OHM/1608*4	1	EA
RN66	CRJ104DJ101T	RES , 4ARRAY (1608*4)	100 OHM/1608*4	1	EA
RN71	CRJ104DJ103T	RES , 4ARRAY (1608*4)	10K OHM/1608*4	1	EA
RN72	CRJ104DJ103T	RES , 4ARRAY (1608*4)	10K OHM/1608*4	1	EA
RN73	CRJ104DJ103T	RES , 4ARRAY (1608*4)	10K OHM/1608*4	1	EA
RN74	CRJ104DJ330T	RES , 4ARRAY (1608*4)	33 OHM/1608*4	1	EA

Ref. Designator	Part Number	Description		Qty	
INPUT PCB (CUP11913-1)					
RN75	CRJ104DJ330T	RES , 4ARRAY (1608*4)	33 OHM/1608*4	1	EA
RN76	CRJ104DJ330T	RES , 4ARRAY (1608*4)	33 OHM/1608*4	1	EA
RN77	CRJ104DJ330T	RES , 4ARRAY (1608*4)	33 OHM/1608*4	1	EA
RN78	CRJ104DJ330T	RES , 4ARRAY (1608*4)	33 OHM/1608*4	1	EA
RN79	CRJ104DJ330T	RES , 4ARRAY (1608*4)	33 OHM/1608*4	1	EA
RN80	CRJ104DJ330T	RES , 4ARRAY (1608*4)	33 OHM/1608*4	1	EA
RN81	CRJ104DJ330T	RES , 4ARRAY (1608*4)	33 OHM/1608*4	1	EA
RN82	CRJ104DJ330T	RES , 4ARRAY (1608*4)	33 OHM/1608*4	1	EA
RN83	CRJ104DJ330T	RES , 4ARRAY (1608*4)	33 OHM/1608*4	1	EA
RN84	CRJ104DJ330T	RES , 4ARRAY (1608*4)	33 OHM/1608*4	1	EA
RN85	CRJ104DJ330T	RES , 4ARRAY (1608*4)	33 OHM/1608*4	1	EA
RN86	CRJ104DJ103T	RES , 4ARRAY (1608*4)	10K OHM/1608*4	1	EA
RN87	CRJ104DJ330T	RES , 4ARRAY (1608*4)	33 OHM/1608*4	1	EA
RN88	CRJ104DJ103T	RES , 4ARRAY (1608*4)	10K OHM/1608*4	1	EA
RN89	CRJ104DJ103T	RES , 4ARRAY (1608*4)	10K OHM/1608*4	1	EA
RN90	CRJ104DJ330T	RES , 4ARRAY (1608*4)	33 OHM/1608*4	1	EA
RN91	CRJ104DJ330T	RES , 4ARRAY (1608*4)	33 OHM/1608*4	1	EA
RN92	CRJ104DJ101T	RES , 4ARRAY (1608*4)	100 OHM/1608*4	1	EA
R201	CRJ10DJ101T	RES , CHIP	100 OHM	1	EA
R202	CRJ10DJ101T	RES , CHIP	100 OHM	1	EA
R203	CRJ10DJ101T	RES , CHIP	100 OHM	1	EA
R204	CRJ10DJ101T	RES , CHIP	100 OHM	1	EA
R205	CRJ10DJ101T	RES , CHIP	100 OHM	1	EA
R206	CRJ10DJ101T	RES , CHIP	100 OHM	1	EA
R207	CRJ10DJ101T	RES , CHIP	100 OHM	1	EA
R208	CRJ10DJ101T	RES , CHIP	100 OHM	1	EA
R209	CRJ10DJ101T	RES , CHIP	100 OHM	1	EA
R210	CRJ10DJ101T	RES , CHIP	100 OHM	1	EA
R211	CRJ10DJ101T	RES , CHIP	100 OHM	1	EA
R212	CRJ10DJ101T	RES , CHIP	100 OHM	1	EA
R213	CRJ10DJ101T	RES , CHIP	100 OHM	1	EA
R214	CRJ10DJ101T	RES , CHIP	100 OHM	1	EA
R215	CRJ10DJ101T	RES , CHIP	100 OHM	1	EA
R216	CRJ10DJ101T	RES , CHIP	100 OHM	1	EA
R219	CRJ10DJ101T	RES , CHIP	100 OHM	1	EA
R220	CRJ10DJ101T	RES , CHIP	100 OHM	1	EA
R221	CRJ10DJ101T	RES , CHIP	100 OHM	1	EA
R222	CRJ10DJ101T	RES , CHIP	100 OHM	1	EA
R223	CRJ10DJ101T	RES , CHIP	100 OHM	1	EA
R224	CRJ10DJ272T	RES , CHIP	2.7K OHM	1	EA
R225	CRJ10DJ101T	RES , CHIP	100 OHM	1	EA
R226	CRJ10DJ101T	RES , CHIP	100 OHM	1	EA
R227	CRJ10DJ474T	RES , CHIP	470K OHM	1	EA
R228	CRJ10DJ474T	RES , CHIP	470K OHM	1	EA
R229	CRJ10DJ474T	RES , CHIP	470K OHM	1	EA
R230	CRJ10DJ474T	RES , CHIP	470K OHM	1	EA
R231	CRJ10DJ474T	RES , CHIP	470K OHM	1	EA
R232	CRJ10DJ474T	RES , CHIP	470K OHM	1	EA
R233	CRJ10DJ474T	RES , CHIP	470K OHM	1	EA
R234	CRJ10DJ474T	RES , CHIP	470K OHM	1	EA
R235	CRJ10DJ474T	RES , CHIP	470K OHM	1	EA
R236	CRJ10DJ474T	RES , CHIP	470K OHM	1	EA
R237	CRJ10DJ474T	RES , CHIP	470K OHM	1	EA
R238	CRJ10DJ474T	RES , CHIP	470K OHM	1	EA
R239	CRJ10DJ474T	RES , CHIP	470K OHM	1	EA
R240	CRJ10DJ474T	RES , CHIP	470K OHM	1	EA
R241	CRJ10DJ474T	RES , CHIP	470K OHM	1	EA
R242	CRJ10DJ474T	RES , CHIP	470K OHM	1	EA
R245	CRJ10DJ474T	RES , CHIP	470K OHM	1	EA
R246	CRJ10DJ474T	RES , CHIP	470K OHM	1	EA
R247	CRJ10DJ474T	RES , CHIP	470K OHM	1	EA

Ref. Designator	Part Number	Description		Qty	
INPUT PCB (CUP11913-1)					
R248	CRJ10DJ474T	RES , CHIP	470K OHM	1	EA
R249	CRJ10DJ474T	RES , CHIP	470K OHM	1	EA
R250	CRJ10DJ103T	RES , CHIP	10K OHM	1	EA
R251	CRJ10DJ474T	RES , CHIP	470K OHM	1	EA
R252	CRJ10DJ474T	RES , CHIP	470K OHM	1	EA
R253	CRJ10DJ4R7T	RES , CHIP	4.7 OHM	1	EA
R254	CRJ10DJ4R7T	RES , CHIP	4.7 OHM	1	EA
R255	CRJ10DJ4R7T	RES , CHIP	4.7 OHM	1	EA
R256	CRJ10DJ4R7T	RES , CHIP	4.7 OHM	1	EA
R257	CRJ10DJ4R7T	RES , CHIP	4.7 OHM	1	EA
R258	CRJ10DJ4R7T	RES , CHIP	4.7 OHM	1	EA
R259	CRJ10DJ4R7T	RES , CHIP	4.7 OHM	1	EA
R260	CRJ10DJ4R7T	RES , CHIP	4.7 OHM	1	EA
R261	CRJ10DJ184T	RES , CHIP	180K OHM	1	EA
R262	CRJ10DJ184T	RES , CHIP	180K OHM	1	EA
R263	CRJ10DJ184T	RES , CHIP	180K OHM	1	EA
R264	CRJ10DJ184T	RES , CHIP	180K OHM	1	EA
R265	CRJ10DJ184T	RES , CHIP	180K OHM	1	EA
R266	CRJ10DJ184T	RES , CHIP	180K OHM	1	EA
R267	CRJ10DJ184T	RES , CHIP	180K OHM	1	EA
R268	CRJ10DJ184T	RES , CHIP	180K OHM	1	EA
R271	CRJ10DJ102T	RES , CHIP	1K OHM	1	EA
R272	CRJ10DJ102T	RES , CHIP	1K OHM	1	EA
R273	CRJ10DJ102T	RES , CHIP	1K OHM	1	EA
R274	CRJ10DJ102T	RES , CHIP	1K OHM	1	EA
R275	CRJ10DJ102T	RES , CHIP	1K OHM	1	EA
R276	CRJ10DJ102T	RES , CHIP	1K OHM	1	EA
R277	CRJ10DJ102T	RES , CHIP	1K OHM	1	EA
R278	CRJ10DJ102T	RES , CHIP	1K OHM	1	EA
R279	CRJ10DJ101T	RES , CHIP	100 OHM	1	EA
R280	CRJ10DJ101T	RES , CHIP	100 OHM	1	EA
R281	CRJ10DJ512T	RES , CHIP	5.1K OHM	1	EA
R282	CRJ10DJ512T	RES , CHIP	5.1K OHM	1	EA
R283	CRJ10DJ512T	RES , CHIP	5.1K OHM	1	EA
R284	CRJ10DJ912T	RES , CHIP	9.1K OHM	1	EA
R285	CRJ10DJ512T	RES , CHIP	5.1K OHM	1	EA
R286	CRJ10DJ512T	RES , CHIP	5.1K OHM	1	EA
R287	CRJ10DJ512T	RES , CHIP	5.1K OHM	1	EA
R288	CRJ10DJ512T	RES , CHIP	5.1K OHM	1	EA
R289	CRJ10DJ101T	RES , CHIP	100 OHM	1	EA
R290	CRJ10DJ101T	RES , CHIP	100 OHM	1	EA
R291	CRJ10DJ184T	RES , CHIP	180K OHM	1	EA
R292	CRJ10DJ184T	RES , CHIP	180K OHM	1	EA
R293	CRJ10DJ184T	RES , CHIP	180K OHM	1	EA
R294	CRJ10DJ184T	RES , CHIP	180K OHM	1	EA
R295	CRJ10DJ184T	RES , CHIP	180K OHM	1	EA
R296	CRJ10DJ184T	RES , CHIP	180K OHM	1	EA
R297	CRJ10DJ184T	RES , CHIP	180K OHM	1	EA
R298	CRJ10DJ184T	RES , CHIP	180K OHM	1	EA
R301	CRJ10DJ122T	RES , CHIP	1.2K OHM	1	EA
R302	CRJ10DJ122T	RES , CHIP	1.2K OHM	1	EA
R303	CRJ10DJ122T	RES , CHIP	1.2K OHM	1	EA
R304	CRJ10DJ122T	RES , CHIP	1.2K OHM	1	EA
R305	CRJ10DJ272T	RES , CHIP	2.7K OHM	1	EA
R306	CRJ10DJ272T	RES , CHIP	2.7K OHM	1	EA
R307	CRJ10DJ272T	RES , CHIP	2.7K OHM	1	EA
R308	CRJ10DJ272T	RES , CHIP	2.7K OHM	1	EA
R309	CRJ10DJ272T	RES , CHIP	2.7K OHM	1	EA
R310	CRJ10DJ272T	RES , CHIP	2.7K OHM	1	EA
R311	CRJ10DJ272T	RES , CHIP	2.7K OHM	1	EA
R312	CRJ10DJ272T	RES , CHIP	2.7K OHM	1	EA

Ref. Designator	Part Number	Description		Qty	
INPUT PCB (CUP11913-1)					
R313	CRJ10DJ272T	RES , CHIP	2.7K OHM	1	EA
R314	CRJ10DJ272T	RES , CHIP	2.7K OHM	1	EA
R315	CRJ10DJ272T	RES , CHIP	2.7K OHM	1	EA
R316	CRJ10DJ272T	RES , CHIP	2.7K OHM	1	EA
R317	CRJ10DJ561T	RES , CHIP	560 OHM	1	EA
R318	CRJ10DF3920T	RES. CHIP (392R 1%)	392 OHM	1	EA
R321	CRJ10DJ512T	RES , CHIP	5.1K OHM	1	EA
R322	CRJ10DJ821T	RES , CHIP	820 OHM	1	EA
R323	CRJ10DJ821T	RES , CHIP	820 OHM	1	EA
R324	CRJ10DJ512T	RES , CHIP	5.1K OHM	1	EA
R325	CRJ10DJ512T	RES , CHIP	5.1K OHM	1	EA
R326	CRJ10DJ821T	RES , CHIP	820 OHM	1	EA
R327	CRJ10DJ821T	RES , CHIP	820 OHM	1	EA
R328	CRJ10DJ103T	RES , CHIP	10K OHM	1	EA
R329	CRJ10DJ512T	RES , CHIP	5.1K OHM	1	EA
R330	CRJ10DJ821T	RES , CHIP	820 OHM	1	EA
R331	CRJ10DJ821T	RES , CHIP	820 OHM	1	EA
R332	CRJ10DJ512T	RES , CHIP	5.1K OHM	1	EA
R333	CRJ10DJ512T	RES , CHIP	5.1K OHM	1	EA
R334	CRJ10DJ821T	RES , CHIP	820 OHM	1	EA
R335	CRJ10DJ821T	RES , CHIP	820 OHM	1	EA
R336	CRJ10DJ512T	RES , CHIP	5.1K OHM	1	EA
R341	CRJ10DJ821T	RES , CHIP	820 OHM	1	EA
R344	CRJ10DJ821T	RES , CHIP	820 OHM	1	EA
R345	CRJ10DJ821T	RES , CHIP	820 OHM	1	EA
R348	CRJ10DJ821T	RES , CHIP	820 OHM	1	EA
R349	CRJ10DJ821T	RES , CHIP	820 OHM	1	EA
R352	CRJ10DJ821T	RES , CHIP	820 OHM	1	EA
R353	CRJ10DJ821T	RES , CHIP	820 OHM	1	EA
R356	CRJ10DJ821T	RES , CHIP	820 OHM	1	EA
R361	CRJ10DJ104T	RES , CHIP	100K OHM	1	EA
R362	CRJ10DJ104T	RES , CHIP	100K OHM	1	EA
R363	CRJ10DJ104T	RES , CHIP	100K OHM	1	EA
R364	CRJ10DJ104T	RES , CHIP	100K OHM	1	EA
R365	CRJ10DJ104T	RES , CHIP	100K OHM	1	EA
R366	CRJ10DJ104T	RES , CHIP	100K OHM	1	EA
R367	CRJ10DJ104T	RES , CHIP	100K OHM	1	EA
R368	CRJ10DJ104T	RES , CHIP	100K OHM	1	EA
R371	CRJ10DJ512T	RES , CHIP	5.1K OHM	1	EA
R372	CRJ10DJ512T	RES , CHIP	5.1K OHM	1	EA
R373	CRJ10DJ512T	RES , CHIP	5.1K OHM	1	EA
R374	CRJ10DJ103T	RES , CHIP	10K OHM	1	EA
R375	CRJ10DJ512T	RES , CHIP	5.1K OHM	1	EA
R376	CRJ10DJ512T	RES , CHIP	5.1K OHM	1	EA
R377	CRJ10DJ512T	RES , CHIP	5.1K OHM	1	EA
R378	CRJ10DJ512T	RES , CHIP	5.1K OHM	1	EA
R381	CRJ10DJ561T	RES , CHIP	560 OHM	1	EA
R382	CRJ10DJ561T	RES , CHIP	560 OHM	1	EA
R383	CRJ10DJ561T	RES , CHIP	560 OHM	1	EA
R384	CRJ10DJ561T	RES , CHIP	560 OHM	1	EA
R385	CRJ10DJ561T	RES , CHIP	560 OHM	1	EA
R386	CRJ10DJ561T	RES , CHIP	560 OHM	1	EA
R387	CRJ10DJ561T	RES , CHIP	560 OHM	1	EA
R388	CRJ10DJ561T	RES , CHIP	560 OHM	1	EA
R389	CRJ10DJ184T	RES , CHIP	180K OHM	1	EA
R390	CRJ10DJ184T	RES , CHIP	180K OHM	1	EA
R391	CRJ10DF3920T	RES. CHIP (392R 1%)	392 OHM	1	EA
R392	CRJ10DF3920T	RES. CHIP (392R 1%)	392 OHM	1	EA
R393	CRJ10DF3920T	RES. CHIP (392R 1%)	392 OHM	1	EA
R394	CRJ10DF3920T	RES. CHIP (392R 1%)	392 OHM	1	EA
R395	CRJ10DF3920T	RES. CHIP (392R 1%)	392 OHM	1	EA

Ref. Designator	Part Number	Description		Qty	
INPUT PCB (CUP11913-1)					
R396	CRJ10DF3920T	RES. CHIP (392R 1%)	392 OHM	1	EA
R397	CRJ10DF3920T	RES. CHIP (392R 1%)	392 OHM	1	EA
R398	CRJ10DF3920T	RES. CHIP (392R 1%)	392 OHM	1	EA
R531	CRJ10DJ152T	RES , CHIP	1.5K OHM	1	EA
R532	CRJ10DJ152T	RES , CHIP	1.5K OHM	1	EA
R533	CRJ10DJ152T	RES , CHIP	1.5K OHM	1	EA
R534	CRJ10DJ152T	RES , CHIP	1.5K OHM	1	EA
R701	CRJ10DJ103T	RES , CHIP	10K OHM	1	EA
R702	CRJ10DJ103T	RES , CHIP	10K OHM	1	EA
R709	CRJ10DJ103T	RES , CHIP	10K OHM	1	EA
R710	CRJ10DJ103T	RES , CHIP	10K OHM	1	EA
R711	CRJ10DJ101T	RES , CHIP	100 OHM	1	EA
R712	CRJ10DJ820T	RES , CHIP	82 OHM	1	EA
R713	CRJ10DJ101T	RES , CHIP	100 OHM	1	EA
R714	CRJ10DJ104T	RES , CHIP	100K OHM	1	EA
R715	CRJ10DJ104T	RES , CHIP	100K OHM	1	EA
R716	CRJ10DJ472T	RES , CHIP	4.7 OHM	1	EA
R717	CRJ10DJ0R0T	RES , CHIP	0 OHM	1	EA
R718	CRJ10DJ332T	RES , CHIP	3.3K. OHM	1	EA
R719	CRJ10DJ0R0T	RES , CHIP	0 OHM	1	EA
R720	CRJ10DJ0R0T	RES , CHIP	0 OHM	1	EA
R721	CRJ10DJ330T	RES , CHIP	33 OHM	1	EA
R724	CRJ10DJ101T	RES , CHIP	100 OHM	1	EA
R725	CRJ10DJ0R0T	RES , CHIP	0 OHM	1	EA
R726	CRJ10DJ100T	RES , CHIP	10 OHM	1	EA
R727	CRJ10DJ0R0T	RES , CHIP	0 OHM	1	EA
R728	CRJ10DJ102T	RES , CHIP	1K OHM	1	EA
R729	CRJ10DJ102T	RES , CHIP	1K OHM	1	EA
R730	CRJ10DJ102T	RES , CHIP	1K OHM	1	EA
R731	CRJ10DJ102T	RES , CHIP	1K OHM	1	EA
R737	CRJ10DJ330T	RES , CHIP	33 OHM	1	EA
R738	CRJ10DJ103T	RES , CHIP	10K OHM	1	EA
R739	CRJ10DJ1R0T	RES , CHIP	1 OHM	1	EA
R740	CRJ10DJ820T	RES , CHIP	82 OHM	1	EA
R741	CRJ10DJ330T	RES , CHIP	33 OHM	1	EA
R742	CRJ10DJ330T	RES , CHIP	33 OHM	1	EA
R743	CRJ10DJ330T	RES , CHIP	33 OHM	1	EA
R744	CRJ10DJ0R0T	RES , CHIP	0 OHM	1	EA
R747	CRJ10DJ330T	RES , CHIP	33 OHM	1	EA
R748	CRJ10DJ330T	RES , CHIP	33 OHM	1	EA
R751	CRJ10DJ820T	RES , CHIP	82 OHM	1	EA
R752	CRJ10DJ330T	RES , CHIP	33 OHM	1	EA
R753	CRJ10DJ103T	RES , CHIP	10K OHM	1	EA
R754	CRJ10DJ103T	RES , CHIP	10K OHM	1	EA
R756	CRJ10DJ103T	RES , CHIP	10K OHM	1	EA
R759	CRJ10DJ101T	RES , CHIP	100 OHM	1	EA
R760	CRJ10DJ105T	RES , CHIP	1M OHM	1	EA
R761	CRJ10DJ102T	RES , CHIP	1K OHM	1	EA
R762	CRJ10DJ102T	RES , CHIP	1K OHM	1	EA
R763	CRJ10DJ472T	RES , CHIP	4.7K OHM	1	EA
R765	CRJ10DJ103T	RES , CHIP	10K OHM	1	EA
R766	CRJ10DJ103T	RES , CHIP	10K OHM	1	EA
R767	CRJ10DJ301T	RES , CHIP	300 OHM	1	EA
R768	CRJ10DJ562T	RES , CHIP	5.6K OHM	1	EA
R770	CRJ10DJ100T	RES , CHIP	10 OHM	1	EA
R771	CRJ10DJ103T	RES , CHIP	10K OHM	1	EA
R772	CRJ10DJ473T	RES , CHIP	47K OHM	1	EA
R773	CRJ10DJ332T	RES , CHIP	3.3K OHM	1	EA
R774	CRJ10DJ332T	RES , CHIP	3.3K OHM	1	EA
R775	CRJ10DJ332T	RES , CHIP	3.3K OHM	1	EA
R776	CRJ10DJ332T	RES , CHIP	3.3K OHM	1	EA

Ref. Designator	Part Number	Description		Qty	
INPUT PCB (CUP11913-1)					
R777	CRJ10DJ102T	RES , CHIP	1K OHM	1	EA
R778	CRJ10DJ103T	RES , CHIP	10K OHM	1	EA
R779	CRJ10DJ103T	RES , CHIP	10K OHM	1	EA
R780	CRJ10DJ103T	RES , CHIP	10K OHM	1	EA
R781	CRJ10DJ103T	RES , CHIP	10K OHM	1	EA
R782	CRJ10DJ272T	RES , CHIP	2.7K OHM	1	EA
R783	CRJ10DJ272T	RES , CHIP	2.7K OHM	1	EA
R784	CRJ10DJ473T	RES , CHIP	47K OHM	1	EA
R785	CRJ10DJ104T	RES , CHIP	100K OHM	1	EA
R786	CRJ10DJ471T	RES , CHIP	470 OHM	1	EA
R787	CRJ10DJ103T	RES , CHIP	10K OHM	1	EA
R788	CRJ10DJ103T	RES , CHIP	10K OHM	1	EA
R789	CRJ10DJ103T	RES , CHIP	10K OHM	1	EA
R791	CRJ10DJ103T	RES , CHIP	10K OHM	1	EA
R792	CRJ10DJ103T	RES , CHIP	10K OHM	1	EA
R794	CRJ10DJ102T	RES , CHIP	1K OHM	1	EA
R795	CRJ10DJ103T	RES , CHIP	10K OHM	1	EA
R796	CRJ10DJ101T	RES , CHIP	100 OHM	1	EA
R797	CRJ10DJ1R0T	RES , CHIP	1 OHM	1	EA
R799	CRJ10DJ103T	RES , CHIP	10K OHM	1	EA
R104	CRQ14AJ220H	RES , FUSIBLE	22 OHM	1	EA
<i>Miscellaneous</i>					
X702	HOX27000E180S	CRYSTAL , 27MHZ(SMD)	27MHz	1	EA
BN17	KJP12GB142ZP	PIN HEADER	PIN HEADER	1	EA
BN19	CJP15GA117ZY	WAFER , CARD CABLE	WAFER	1	EA
BN43	CWB1C903200BM	WIRE ASS'Y	WIRE	1	EA
BN44	CJP11GA117ZY	WAFER	WAFER	1	EA
CN10	CJP04GB46ZY	WAFER	WAFER	1	EA
CN11	CJP17GA117ZY	WAFER	WAFER	1	EA
CN12	CJP21GA115ZY	WAFER , CARD CABLE	WAFER	1	EA
CN13	CJP13GA115ZY	WAFER , CARD CABLE	WAFER	1	EA
CN14	CJP17GA117ZY	WAFER	WAFER	1	EA
CN15	CJP15GA117ZY	WAFER , CARD CABLE	WAFER	1	EA
CN16	CJP12GA115ZY	WAFER , CARD CABLE	WAFER	1	EA
CN17	KJP12GB142ZP	PIN HEADER	PIN HEADER	1	EA
CN18	CJP05GA19ZY	WAFER, STRAIGHT, 5PIN	WAFER	1	EA
CN19	CJP15GA117ZY	WAFER , CARD CABLE	WAFER	1	EA
CN20	CJP05GA01ZY	CON WAFER YMW025-05R	WAFER	1	EA
CN21	CJP07GA117ZY	TEMP ITEM	WAFER	1	EA
CN22	CJP06GA19ZY	WAFER, STRAIGHT, 6PIN	WAFER	1	EA
CN72	CJP17GA117ZY	WAFER	WAFER	1	EA
CN85	CJP02GA01ZY	WAFER, STRAIGHT, 2PIN	WAFER	1	EA
CN89	CJP02GA01ZY	WAFER, STRAIGHT, 2PIN	WAFER	1	EA
CN90	CJP02GA19ZY	WAFER, 2PIN	WAFER	1	EA
CN95	CJP03GA19ZY	WAFER, STRAIGHT, 3PIN	WAFER	1	EA
CN97	CJP03GA01ZY	WAFER	WAFER	1	EA
CN99	CJP08GA19ZY	WAFER, STRAIGHT, 8PIN	WAFER	1	EA
ET02	CMD1A570	BRACKET , PCB	BRACKET	1	EA
ET03	CMD1A569	BRACKET , PCB	BRACKET	1	EA
JK11	CJJ4R019W	TERMINAL , IN/OUT	TERMINAL	1	EA
JK12	CJJ4R019W	TERMINAL , IN/OUT	TERMINAL	1	EA
JK13	CJJ4R019W	TERMINAL , IN/OUT	TERMINAL	1	EA
JK14	CJJ4R037W	JACK , BOARD	JACK	1	EA
JW21	CWE7202070AA	WIRE ASS'Y	WIRE	1	EA
X701	HOX24576E150TF	CRYSTAL	24.576MHZ	1	EA
L701	HLZ9Z014Z	CHIP , BEAD	HU-1H4516-600JT	1	EA
L702	HLZ9Z014Z	CHIP , BEAD	HU-1H4516-600JT	1	EA
L703	HLZ9Z014Z	CHIP , BEAD	HU-1H4516-600JT	1	EA
L704	HLZ9R005Z	BEAD CHIP 60(1608 SIZE)	HH-1M1608-600	1	EA

Ref. Designator	Part Number	Description		Qty	
INPUT PCB (CUP11913-1)					
L705	HLZ9R005Z	BEAD CHIP 60(1608 SIZE)	HH-1M1608-600	1	EA
MAIN PCB (CUP11911)					
<i>Capacitors</i>					
C501	CCEA1HH100T	CAP , ELECT	10UF 50V	1	EA
C502	CCEA1HH100T	CAP , ELECT	10UF 50V	1	EA
C503	CCEA1HH100T	CAP , ELECT	10UF 50V	1	EA
C504	CCEA1HH100T	CAP , ELECT	10UF 50V	1	EA
C505	CCEA1HH100T	CAP , ELECT	10UF 50V	1	EA
C506	CCKT1H331KB	CAP , CERAMIC	330PF 50V	1	EA
C507	HCBS1H331KBT	CAP , CERAMIC	330PF 50V	1	EA
C508	HCBS1H331KBT	CAP , CERAMIC	330PF 50V	1	EA
C509	CCKT1H331KB	CAP , CERAMIC	330PF 50V	1	EA
C510	HCBS1H331KBT	CAP , CERAMIC	330PF 50V	1	EA
C561	CCEA1CH101T	CAP , ELECT	100UF 16V	1	EA
C562	CCEA1CH101T	CAP , ELECT	100UF 16V	1	EA
C563	CCEA1CH101T	CAP , ELECT	100UF 16V	1	EA
C564	CCEA1CH101T	CAP , ELECT	100UF 16V	1	EA
C565	CCEA1CH101T	CAP , ELECT	100UF 16V	1	EA
C566	CCEA1CH101T	CAP , ELECT	100UF 16V	1	EA
C567	CCEA1CH101T	CAP , ELECT	100UF 16V	1	EA
C568	CCEA1CH101T	CAP , ELECT	100UF 16V	1	EA
C569	CCEA1CH101T	CAP , ELECT	100UF 16V	1	EA
C570	CCEA1CH101T	CAP , ELECT	100UF 16V	1	EA
C571	HCBS1H681KBT	CAP , CERAMIC	680PF 50V	1	EA
C572	HCBS1H681KBT	CAP , CERAMIC	680PF 50V	1	EA
C573	HCBS1H681KBT	CAP , CERAMIC	680PF 50V	1	EA
C574	HCBS1H681KBT	CAP , CERAMIC	680PF 50V	1	EA
C575	HCBS1H681KBT	CAP , CERAMIC	680PF 50V	1	EA
C601	CCCT1H120JC	CAP , CERAMIC	12PF 50V	1	EA
C602	CCCT1H120JC	CAP , CERAMIC	12PF 50V	1	EA
C603	CCCT1H120JC	CAP , CERAMIC	12PF 50V	1	EA
C604	CCCT1H120JC	CAP , CERAMIC	12PF 50V	1	EA
C605	CCCT1H120JC	CAP , CERAMIC	12PF 50V	1	EA
C606	CCCT1H330JC	CAP , CERAMIC	33PF 50V	1	EA
C607	CCCT1H330JC	CAP , CERAMIC	33PF 50V	1	EA
C608	CCCT1H330JC	CAP , CERAMIC	33PF 50V	1	EA
C609	CCCT1H330JC	CAP , CERAMIC	33PF 50V	1	EA
C610	CCCT1H330JC	CAP , CERAMIC	33PF 50V	1	EA
C681	CCEA1HH100T	CAP , ELECT	10UF 50V	1	EA
C682	CCEA1HH100T	CAP , ELECT	10UF 50V	1	EA
C683	CCEA1HH100T	CAP , ELECT	10UF 50V	1	EA
C684	CCEA1HH100T	CAP , ELECT	10UF 50V	1	EA
C685	CCEA1HH100T	CAP , ELECT	10UF 50V	1	EA
C721	CCKT1H221KB	CAP , CERAMIC	220PF 50V	1	EA
C722	CCKT1H221KB	CAP , CERAMIC	220PF 50V	1	EA
C723	CCKT1H221KB	CAP , CERAMIC	220PF 50V	1	EA
C724	CCKT1H221KB	CAP , CERAMIC	220PF 50V	1	EA
C725	CCKT1H221KB	CAP , CERAMIC	220PF 50V	1	EA
C726	CCKT1H221KB	CAP , CERAMIC	220PF 50V	1	EA
C727	CCKT1H221KB	CAP , CERAMIC	220PF 50V	1	EA
C728	CCKT1H221KB	CAP , CERAMIC	220PF 50V	1	EA
C801	CCEA1HH100T	CAP , ELECT	10UF 50V	1	EA
C802	CCEA1HH100T	CAP , ELECT	10UF 50V	1	EA
C803	CCCT1H330JC	CAP , CERAMIC	33PF 50V	1	EA
C804	CCCT1H330JC	CAP , CERAMIC	33PF 50V	1	EA
C805	CCCT1H120JC	CAP , CERAMIC	12PF 50V	1	EA
C806	CCCT1H120JC	CAP , CERAMIC	12PF 50V	1	EA
C811	CCEA1CH101T	CAP , ELECT	100UF 16V	1	EA

Ref. Designator	Part Number	Description		Qty	
MAIN PCB (CUP11911)					
C812	CCEA1CH101T	CAP , ELECT	100UF 16V	1	EA
C813	CCEA1CH101T	CAP , ELECT	100UF 16V	1	EA
C814	CCEA1CH101T	CAP , ELECT	100UF 16V	1	EA
C815	CCKT1H331KB	CAP , CERAMIC	330PF 50V	1	EA
C816	HCBS1H331KBT	CAP , CERAMIC	330PF 50V	1	EA
C817	CCEA1HH100T	CAP , ELECT	10UF 50V	1	EA
C818	CCEA1HH100T	CAP , ELECT	10UF 50V	1	EA
C819	HCBS1H681KBT	CAP , CERAMIC	680PF 50V	1	EA
C820	HCBS1H681KBT	CAP , CERAMIC	680PF 50V	1	EA
C900	HCQ11H473JZT	CAP , MYLAR	0.047UF 50V	1	EA
C901	HCQ11H473JZT	CAP , MYLAR	0.047UF 50V	1	EA
C905	CCFT1H223ZF	CAP , CERAMIC	0.022UP 50V	1	EA
C907	CCEA1CH101T	CAP , ELECT	100UF 16V	1	EA
C908	CCFT1H223ZF	CAP , CERAMIC	0.022UP 50V	1	EA
C910	HCQ11H473JZT	CAP , MYLAR	0.047UF 50V	1	EA
C912	CCEA1CH221T	CAP , ELECT	220UF 16V	1	EA
C913	CCFT1H104ZF	CAP , SEMICONDUCTOR	0.1UF 50V ZF	1	EA
C914	HCQ11H473JZT	CAP , MYLAR	0.047UF 50V J	1	EA
C917	HCQ11H473JZT	CAP , MYLAR	0.047UF 50V J	1	EA
C918	HCQ11H473JZT	CAP , MYLAR	0.047UF 50V J	1	EA
C919	HCQ11H473JZT	CAP , MYLAR	0.047UF 50V J	1	EA
C924	CCFT1H104ZF	CAP , SEMICONDUCTOR	0.1UF 50V ZF	1	EA
C925	CCFT1H104ZF	CAP , SEMICONDUCTOR	0.1UF 50V ZF	1	EA
C932	CCEA1CH101T	CAP , ELECT	100UF 16V	1	EA
C933	CCEA1CH221T	CAP , ELECT	220UF 16V	1	EA
C934	CCFT1H223ZF	CAP , CERAMIC	0.022UP 50V	1	EA
C939	CCEA1HH4R7T	CAP , ELECT	4.7UF 50V	1	EA
C940	CCEA1AH471T	CAP , ELECT	470UF 10V	1	EA
C948	CCFT1H104ZF	CAP , SEMICONDUCTOR	0.1UF 50V ZF	1	EA
C949	CCEA1HH220T	CAP , ELECT	22UF 50V	1	EA
C950	CCEA1AH471T	CAP , ELECT	470UF 10V	1	EA
C971	HCQ11H562JZT	CAP , MYLAR	5600PF 50V	1	EA
C972	HCQ11H562JZT	CAP , MYLAR	5600PF 50V	1	EA
C973	HCQ11H562JZT	CAP , MYLAR	5600PF 50V	1	EA
C974	HCQ11H562JZT	CAP , MYLAR	5600PF 50V	1	EA
C975	HCQ11H562JZT	CAP , MYLAR	5600PF 50V	1	EA
C980	HCQ11H562JZT	CAP , MYLAR	5600PF 50V	1	EA
C981	HCQ11H562JZT	CAP , MYLAR	5600PF 50V	1	EA
C990	HCQ11H473JZT	CAP , MYLAR	0.047UF 50V J	1	EA
C991	CCEA1HH1R0T	CAP , ELECT	1UF 50V	1	EA
C992	HCQ11H473JZT	CAP , MYLAR	0.047UF 50V J	1	EA
C993	HCQ11H473JZT	CAP , MYLAR	0.047UF 50V J	1	EA
C994	HCQ11H473JZT	CAP , MYLAR	0.047UF 50V J	1	EA
C995	HCQ11H473JZT	CAP , MYLAR	0.047UF 50V J	1	EA
C996	HCQ11H473JZT	CAP , MYLAR	0.047UF 50V J	1	EA
C997	HCQ11H473JZT	CAP , MYLAR	0.047UF 50V J	1	EA
C999	CCFT1H223ZF	CAP , CERAMIC	0.022UF 50V ZF	1	EA
C631	CCEA1JH221E	CAP , ELECT	220UF 63V	1	EA
C632	CCEA1JH221E	CAP , ELECT	220UF 63V	1	EA
C633	CCEA1JH221E	CAP , ELECT	220UF 63V	1	EA
C634	CCEA1JH221E	CAP , ELECT	220UF 63V	1	EA
C635	CCEA1JH221E	CAP , ELECT	220UF 63V	1	EA
C636	CCEA1JH221E	CAP , ELECT	220UF 63V	1	EA
C637	CCEA1JH221E	CAP , ELECT	220UF 63V	1	EA
C638	CCEA1JH221E	CAP , ELECT	220UF 63V	1	EA
C639	CCEA1JH221E	CAP , ELECT	220UF 63V	1	EA
C640	CCEA1JH221E	CAP , ELECT	220UF 63V	1	EA
C807	CCEA1JH221E	CAP , ELECT	220UF 63V	1	EA
C808	CCEA1JH221E	CAP , ELECT	220UF 63V	1	EA
C809	CCEA1JH221E	CAP , ELECT	220UF 63V	1	EA
C810	CCEA1JH221E	CAP , ELECT	220UF 63V	1	EA

Ref. Designator	Part Number	Description		Qty	
MAIN PCB (CUP11911)					
C902	CCET63VKL5822NK	CAP , ELECT	8200UF 63V	1	EA
C904	KCKDKS472ME	CAP , CERAMIC(X1/Y2/SC)	0.0047UF 2.5KV	1	EA
C906	CCEA1EH102E	CAP , ELECT	1000UF 25V	1	EA
C909	CCET63VKL5822NK	CAP , ELECT	8200UF 63V	1	EA
C911	CCEA1EH471T	CAP , ELECT	470UF 25V	1	EA
C915	CCET63VKL5123NK	CAP , ELECT	12000UF 63V	1	EA
C916	CCET63VKL5123NK	CAP , ELECT	12000UF 63V	1	EA
Semiconductors					
D501	CVD1SS133MT	DIODE	1SS133	1	EA
D502	CVD1SS133MT	DIODE	1SS133	1	EA
D503	CVD1SS133MT	DIODE	1SS133	1	EA
D504	CVD1SS133MT	DIODE	1SS133	1	EA
D505	CVD1SS133MT	DIODE	1SS133	1	EA
D581	CVD1SS133MT	DIODE	1SS133	1	EA
D582	CVD1SS133MT	DIODE	1SS133	1	EA
D583	CVD1SS133MT	DIODE	1SS133	1	EA
D584	CVD1SS133MT	DIODE	1SS133	1	EA
D585	CVD1SS133MT	DIODE	1SS133	1	EA
D801	CVD1SS133MT	DIODE	1SS133	1	EA
D802	CVD1SS133MT	DIODE	1SS133	1	EA
D803	CVD1SS133MT	DIODE	1SS133	1	EA
D804	CVD1SS133MT	DIODE	1SS133	1	EA
D901	CVD1N4003SRT	RECT , DIODE	1N4003	1	EA
D902	CVD1SS133MT	DIODE	1SS133	1	EA
D911	CVD1SS133MT	DIODE	1SS133	1	EA
D912	CVD1SS133MT	DIODE	1SS133	1	EA
D914	CVD1SS133MT	DIODE	1SS133	1	EA
D917	CVD1SS133MT	DIODE	1SS133	1	EA
D953	CVD1SS133MT	DIODE	1SS133	1	EA
D954	CVD1N4003SRT	RECT , DIODE	1N4003	1	EA
D955	CVD1N4003SRT	RECT , DIODE	1N4003	1	EA
D956	CVD1N4003SRT	RECT , DIODE	1N4003	1	EA
D957	CVD1N4003SRT	RECT , DIODE	1N4003	1	EA
D961	CVD1N4003ST	RECT , DIODE	1N4003	1	EA
D962	CVD1N4003SRT	RECT , DIODE	1N4003	1	EA
D963	CVD1N4003ST	RECT , DIODE	1N4003	1	EA
D964	CVD1SS133MT	DIODE	1SS133	1	EA
D967	CVD1SS133MT	DIODE	1SS133	1	EA
D968	CVD1SS133MT	DIODE	1SS133	1	EA
D969	CVD1SS133MT	DIODE	1SS133	1	EA
D971	CVD1SS133MT	DIODE	1SS133	1	EA
D972	CVD1SS133MT	DIODE	1SS133	1	EA
D973	CVD1SS133MT	DIODE	1SS133	1	EA
D974	CVD1SS133MT	DIODE	1SS133	1	EA
D979	HVDMTZJ6.2BT	DIODE , ZENER	MTZJ6.2B	1	EA
D980	CVD1SS133MT	DIODE	1SS133	1	EA
Q501	HVTKTA1268GRT	TRANSISTOR PNP	KTA1268GR	1	EA
Q502	HVTKTA1268GRT	TRANSISTOR PNP	KTA1268GR	1	EA
Q503	HVTKTA1268GRT	TRANSISTOR PNP	KTA1268GR	1	EA
Q504	HVTKTA1268GRT	TRANSISTOR PNP	KTA1268GR	1	EA
Q505	HVTKTA1268GRT	TRANSISTOR PNP	KTA1268GR	1	EA
Q511	HVTKTC3200GRT	TRANSISTOR NPN	KTC3200GR	1	EA
Q512	HVTKTC3200GRT	TRANSISTOR NPN	KTC3200GR	1	EA
Q513	HVTKTC3200GRT	TRANSISTOR NPN	KTC3200GR	1	EA
Q514	HVTKTC3200GRT	TRANSISTOR NPN	KTC3200GR	1	EA
Q515	HVTKTC3200GRT	TRANSISTOR NPN	KTC3200GR	1	EA
Q516	HVTKTC3200GRT	TRANSISTOR NPN	KTC3200GR	1	EA
Q517	HVTKTC3200GRT	TRANSISTOR NPN	KTC3200GR	1	EA
Q518	HVTKTC3200GRT	TRANSISTOR NPN	KTC3200GR	1	EA

Ref. Designator	Part Number	Description		Qty	
MAIN PCB (CUP11911)					
Q519	HVTKTC3200GRT	TRANSISTOR NPN	KTC3200GR	1	EA
Q520	HVTKTC3200GRT	TRANSISTOR NPN	KTC3200GR	1	EA
Q541	HVTKTC3198YT	TRANSISTOR NPN	KTC3198Y	1	EA
Q542	HVTKTC3198YT	TRANSISTOR NPN	KTC3198Y	1	EA
Q543	HVTKTC3198YT	TRANSISTOR NPN	KTC3198Y	1	EA
Q544	HVTKTC3198YT	TRANSISTOR NPN	KTC3198Y	1	EA
Q545	HVTKTC3198YT	TRANSISTOR NPN	KTC3198Y	1	EA
Q556	HVTKTC3200GRT	TRANSISTOR NPN	KTC3200GR	1	EA
Q557	HVTKTC3200GRT	TRANSISTOR NPN	KTC3200GR	1	EA
Q558	HVTKTC3200GRT	TRANSISTOR NPN	KTC3200GR	1	EA
Q559	HVTKTC3200GRT	TRANSISTOR NPN	KTC3200GR	1	EA
Q560	HVTKTC3200GRT	TRANSISTOR NPN	KTC3200GR	1	EA
Q561	HVTKTC3200GRT	TRANSISTOR NPN	KTC3200GR	1	EA
Q562	HVTKTC3200GRT	TRANSISTOR NPN	KTC3200GR	1	EA
Q563	HVTKTC3200GRT	TRANSISTOR NPN	KTC3200GR	1	EA
Q564	HVTKTC3200GRT	TRANSISTOR NPN	KTC3200GR	1	EA
Q565	HVTKTC3200GRT	TRANSISTOR NPN	KTC3200GR	1	EA
Q601	HVTKTA1268GRT	TRANSISTOR PNP	KTA1268GR	1	EA
Q602	HVTKTA1268GRT	TRANSISTOR PNP	KTA1268GR	1	EA
Q603	HVTKTA1268GRT	TRANSISTOR PNP	KTA1268GR	1	EA
Q604	HVTKTA1268GRT	TRANSISTOR PNP	KTA1268GR	1	EA
Q605	HVTKTA1268GRT	TRANSISTOR PNP	KTA1268GR	1	EA
Q681	HVTKSC2785YT	TRANSISTOR NPN	KSC2785Y	1	EA
Q682	HVTKSC2785YT	TRANSISTOR NPN	KSC2785Y	1	EA
Q683	HVTKSC2785YT	TRANSISTOR NPN	KSC2785Y	1	EA
Q684	HVTKSC2785YT	TRANSISTOR NPN	KSC2785Y	1	EA
Q685	HVTKSC2785YT	TRANSISTOR NPN	KSC2785Y	1	EA
Q801	HVTKSC2785YT	TRANSISTOR NPN	KSC2785Y	1	EA
Q802	HVTKSC2785YT	TRANSISTOR NPN	KSC2785Y	1	EA
Q812	HVTKTA1268GRT	TRANSISTOR PNP	KTA1268GR	1	EA
Q813	HVTKTC3200GRT	TRANSISTOR NPN	KTC3200GR	1	EA
Q814	HVTKTA1268GRT	TRANSISTOR PNP	KTA1268GR	1	EA
Q815	HVTKTC3200GRT	TRANSISTOR NPN	KTC3200GR	1	EA
Q816	HVTKTA1268GRT	TRANSISTOR PNP	KTA1268GR	1	EA
Q817	HVTKTA1268GRT	TRANSISTOR PNP	KTA1268GR	1	EA
Q818	HVTKTC3200GRT	TRANSISTOR NPN	KTC3200GR	1	EA
Q819	HVTKTC3200GRT	TRANSISTOR NPN	KTC3200GR	1	EA
Q820	HVTKTC3200GRT	TRANSISTOR NPN	KTC3200GR	1	EA
Q821	HVTKTC3200GRT	TRANSISTOR NPN	KTC3200GR	1	EA
Q822	HVTKTC3200GRT	TRANSISTOR NPN	KTC3200GR	1	EA
Q823	HVTKTC3200GRT	TRANSISTOR NPN	KTC3200GR	1	EA
Q824	HVTKTC3198YT	TRANSISTOR NPN	KTC3198Y	1	EA
Q825	HVTKTC3198YT	TRANSISTOR NPN	KTC3198Y	1	EA
Q901	HVTKSC2785YT	TRANSISTOR NPN	KSC2785Y	1	EA
Q911	HVTKTA1271YT	TRANSISTOR PNP	KTA1271Y	1	EA
Q912	HVTKTA1271YT	TRANSISTOR PNP	KTA1271Y	1	EA
Q913	HVTKTA1271YT	TRANSISTOR PNP	KTA1271Y	1	EA
Q914	HVTKTA1271YT	TRANSISTOR PNP	KTA1271Y	1	EA
Q915	HVTKSC2785YT	TRANSISTOR NPN	KSC2785Y	1	EA
Q916	HVTKSC2785YT	TRANSISTOR NPN	KSC2785Y	1	EA
Q917	HVTKSC2785YT	TRANSISTOR NPN	KSC2785Y	1	EA
Q918	HVTKSC2785YT	TRANSISTOR NPN	KSC2785Y	1	EA
Q938	HVTKRA107MT	TRANSISTOR PNP	KRA107M	1	EA
Q939	HVTKRA107MT	TRANSISTOR PNP	KRA107M	1	EA
Q942	HVTKSC2785YT	TRANSISTOR NPN	KSC2785Y	1	EA
Q943	HVTKSC2785YT	TRANSISTOR NPN	KSC2785Y	1	EA
Q951	HVTKRC107MT	TRANSISTOR NPN	KRC107M	1	EA
Q952	HVTKRA107MT	TRANSISTOR PNP	KRA107M	1	EA
Q960	HVTKRC107MT	TRANSISTOR NPN	KRC107M	1	EA
Q961	HVTKTA1024YT	TRANSISTOR PNP	KTA1024YT	1	EA
Q991	HVTKRC107MT	TRANSISTOR NPN	KRC107M	1	EA

Ref. Designator	Part Number	Description		Qty	
MAIN PCB (CUP11911)					
Q992	HVTKRA107MT	TRANSISTOR PNP	KRA107M	1	EA
Q993	HVTKRA107MT	TRANSISTOR PNP	KRA107M	1	EA
Q994	HVTKRC107MT	TRANSISTOR NPN	KRC107M	1	EA
Q997	HVTKRA107MT	TRANSISTOR PNP	KRA107M	1	EA
Q998	HVTKRC107MT	TRANSISTOR NPN	KRC107M	1	EA
IC94	HVIMC7805C	I.C. REGULATOR(+5V)	FAIRCHILD	1	EA
IC97	HVIS-80842CNY-X	I.C. RESET	SEIKO	1	EA
Q858	HVT2SA13600	TRANSISTOR PNP POWER	2SA13600	1	EA
Q871	HVT2SA13600	TRANSISTOR PNP POWER	2SA13600	1	EA
Q872	HVT2SA13600	TRANSISTOR PNP POWER	2SA13600	1	EA
Q874	HVT2SA13600	TRANSISTOR PNP POWER	2SA13600	1	EA
Q875	HVT2SA13600	TRANSISTOR PNP POWER	2SA13600	1	EA
Q876	HVT2SA13600	TRANSISTOR PNP POWER	2SA13600	1	EA
Q877	HVT2SA13600	TRANSISTOR PNP POWER	2SA13600	1	EA
Q881	HVT2SC34230	TRANSISTOR NPN POWER	2SC34230	1	EA
Q882	HVT2SC34230	TRANSISTOR NPN POWER	2SC34230	1	EA
Q883	HVT2SC34230	TRANSISTOR NPN POWER	2SC34230	1	EA
Q884	HVT2SC34230	TRANSISTOR NPN POWER	2SC34230	1	EA
Q885	HVT2SC34230	TRANSISTOR NPN POWER	2SC34230	1	EA
Q886	HVT2SC34230	TRANSISTOR NPN POWER	2SC34230	1	EA
Q887	HVT2SC34230	TRANSISTOR NPN POWER	2SC34230	1	EA
<i>Resistors</i>					
R501	CRD20TJ433T	RES , CARBON	43K OHM 1/5W J	1	EA
R502	CRD20TJ433T	RES , CARBON	43K OHM 1/5W J	1	EA
R503	CRD20TJ433T	RES , CARBON	43K OHM 1/5W J	1	EA
R504	CRD20TJ433T	RES , CARBON	43K OHM 1/5W J	1	EA
R505	CRD20TJ433T	RES , CARBON	43K OHM 1/5W J	1	EA
R506	CRD20TJ333T	RES , CARBON	33K OHM 1/5W J	1	EA
R507	CRD20TJ333T	RES , CARBON	33K OHM 1/5W J	1	EA
R508	CRD20TJ333T	RES , CARBON	33K OHM 1/5W J	1	EA
R509	CRD20TJ333T	RES , CARBON	33K OHM 1/5W J	1	EA
R510	CRD20TJ333T	RES , CARBON	33K OHM 1/5W J	1	EA
R511	CRD20TJ152T	RES , CARBON	1.5K OHM 1/5W J	1	EA
R512	CRD20TJ152T	RES , CARBON	1.5K OHM 1/5W J	1	EA
R513	CRD20TJ152T	RES , CARBON	1.5K OHM 1/5W J	1	EA
R514	CRD20TJ152T	RES , CARBON	1.5K OHM 1/5W J	1	EA
R515	CRD20TJ152T	RES , CARBON	1.5K OHM 1/5W J	1	EA
R516	CRD20TJ152T	RES , CARBON	1.5K OHM 1/5W J	1	EA
R517	CRD20TJ152T	RES , CARBON	1.5K OHM 1/5W J	1	EA
R518	CRD20TJ152T	RES , CARBON	1.5K OHM 1/5W J	1	EA
R519	CRD20TJ152T	RES , CARBON	1.5K OHM 1/5W J	1	EA
R520	CRD20TJ152T	RES , CARBON	1.5K OHM 1/5W J	1	EA
R521	CRD20TJ471T	RES , CARBON	470 OHM 1/5W J	1	EA
R522	CRD20TJ471T	RES , CARBON	470 OHM 1/5W J	1	EA
R523	CRD20TJ471T	RES , CARBON	470 OHM 1/5W J	1	EA
R524	CRD20TJ471T	RES , CARBON	470 OHM 1/5W J	1	EA
R525	CRD20TJ471T	RES , CARBON	470 OHM 1/5W J	1	EA
R531	CRD20TJ221T	RES , CARBON	220 OHM 1/5W J	1	EA
R532	CRD20TJ221T	RES , CARBON	220 OHM 1/5W J	1	EA
R533	CRD20TJ221T	RES , CARBON	220 OHM 1/5W J	1	EA
R534	CRD20TJ221T	RES , CARBON	220 OHM 1/5W J	1	EA
R535	CRD20TJ221T	RES , CARBON	220 OHM 1/5W J	1	EA
R536	CRD20TJ221T	RES , CARBON	220 OHM 1/5W J	1	EA
R537	CRD20TJ221T	RES , CARBON	220 OHM 1/5W J	1	EA
R538	CRD20TJ221T	RES , CARBON	220 OHM 1/5W J	1	EA
R539	CRD20TJ221T	RES , CARBON	220 OHM 1/5W J	1	EA
R540	CRD20TJ221T	RES , CARBON	220 OHM 1/5W J	1	EA
R541	CRD20TJ271T	RES , CARBON	270 OHM 1/5W J	1	EA
R542	CRD20TJ271T	RES , CARBON	270 OHM 1/5W J	1	EA

Ref. Designator	Part Number	Description		Qty	
MAIN PCB (CUP11911)					
R543	CRD20TJ271T	RES , CARBON	270 OHM 1/5W J	1	EA
R544	CRD20TJ271T	RES , CARBON	270 OHM 1/5W J	1	EA
R545	CRD20TJ271T	RES , CARBON	270 OHM 1/5W J	1	EA
R556	CRD20TJ273T	RES , CARBON	27K OHM 1/5W J	1	EA
R557	CRD20TJ273T	RES , CARBON	27K OHM 1/5W J	1	EA
R558	CRD20TJ273T	RES , CARBON	27K OHM 1/5W J	1	EA
R559	CRD20TJ273T	RES , CARBON	27K OHM 1/5W J	1	EA
R560	CRD20TJ273T	RES , CARBON	27K OHM 1/5W J	1	EA
R561	CRD20TJ162T	RES , CARBON	1.6K OHM 1/5W J	1	EA
R562	CRD20TJ162T	RES , CARBON	1.6K OHM 1/5W J	1	EA
R563	CRD20TJ162T	RES , CARBON	1.6K OHM 1/5W J	1	EA
R564	CRD20TJ162T	RES , CARBON	1.6K OHM 1/5W J	1	EA
R565	CRD20TJ162T	RES , CARBON	1.6K OHM 1/5W J	1	EA
R566	CRD20TJ561T	RES , CARBON	560 OHM 1/5W J	1	EA
R567	CRD20TJ561T	RES , CARBON	560 OHM 1/5W J	1	EA
R568	CRD20TJ561T	RES , CARBON	560 OHM 1/5W J	1	EA
R569	CRD20TJ561T	RES , CARBON	560 OHM 1/5W J	1	EA
R570	CRD20TJ561T	RES , CARBON	560 OHM 1/5W J	1	EA
R571	CRD20TJ561T	RES , CARBON	560 OHM 1/5W J	1	EA
R572	CRD20TJ561T	RES , CARBON	560 OHM 1/5W J	1	EA
R573	CRD20TJ561T	RES , CARBON	560 OHM 1/5W J	1	EA
R574	CRD20TJ561T	RES , CARBON	560 OHM 1/5W J	1	EA
R575	CRD20TJ561T	RES , CARBON	560 OHM 1/5W J	1	EA
R576	CRD20TJ100T	RES , CARBON	10 OHM 1/5W J	1	EA
R577	CRD20TJ100T	RES , CARBON	10 OHM 1/5W J	1	EA
R578	CRD20TJ100T	RES , CARBON	10 OHM 1/5W J	1	EA
R579	CRD20TJ100T	RES , CARBON	10 OHM 1/5W J	1	EA
R580	CRD20TJ100T	RES , CARBON	10 OHM 1/5W J	1	EA
R581	CRD20TJ561T	RES , CARBON	560 OHM 1/5W J	1	EA
R582	CRD20TJ561T	RES , CARBON	560 OHM 1/5W J	1	EA
R583	CRD20TJ561T	RES , CARBON	560 OHM 1/5W J	1	EA
R584	CRD20TJ561T	RES , CARBON	560 OHM 1/5W J	1	EA
R585	CRD20TJ561T	RES , CARBON	560 OHM 1/5W J	1	EA
R586	CRD20TJ561T	RES , CARBON	560 OHM 1/5W J	1	EA
R587	CRD20TJ561T	RES , CARBON	560 OHM 1/5W J	1	EA
R588	CRD20TJ561T	RES , CARBON	560 OHM 1/5W J	1	EA
R589	CRD20TJ561T	RES , CARBON	560 OHM 1/5W J	1	EA
R590	CRD20TJ561T	RES , CARBON	560 OHM 1/5W J	1	EA
R591	CRD20TJ561T	RES , CARBON	560 OHM 1/5W J	1	EA
R592	CRD20TJ561T	RES , CARBON	560 OHM 1/5W J	1	EA
R593	CRD20TJ561T	RES , CARBON	560 OHM 1/5W J	1	EA
R594	CRD20TJ561T	RES , CARBON	560 OHM 1/5W J	1	EA
R595	CRD20TJ561T	RES , CARBON	560 OHM 1/5W J	1	EA
R596	CRD20TJ561T	RES , CARBON	560 OHM 1/5W J	1	EA
R597	CRD20TJ561T	RES , CARBON	560 OHM 1/5W J	1	EA
R598	CRD20TJ561T	RES , CARBON	560 OHM 1/5W J	1	EA
R599	CRD20TJ561T	RES , CARBON	560 OHM 1/5W J	1	EA
R600	CRD20TJ561T	RES , CARBON	560 OHM 1/5W J	1	EA
R601	CRD20TJ223T	RES , CARBON	22K OHM 1/5W J	1	EA
R602	CRD20TJ223T	RES , CARBON	22K OHM 1/5W J	1	EA
R603	CRD20TJ223T	RES , CARBON	22K OHM 1/5W J	1	EA
R604	CRD20TJ223T	RES , CARBON	22K OHM 1/5W J	1	EA
R605	CRD20TJ223T	RES , CARBON	22K OHM 1/5W J	1	EA
R606	CRD20TJ223T	RES , CARBON	22K OHM 1/5W J	1	EA
R607	CRD20TJ223T	RES , CARBON	22K OHM 1/5W J	1	EA
R608	CRD20TJ223T	RES , CARBON	22K OHM 1/5W J	1	EA
R609	CRD20TJ223T	RES , CARBON	22K OHM 1/5W J	1	EA
R610	CRD20TJ223T	RES , CARBON	22K OHM 1/5W J	1	EA
R611	CRD20TJ100T	RES , CARBON	10 OHM 1/5W J	1	EA
R612	CRD20TJ100T	RES , CARBON	10 OHM 1/5W J	1	EA
R631	CRD25FJ180T	RES , CARBON	18 OHM 1/4W	1	EA

Ref. Designator	Part Number	Description		Qty	
MAIN PCB (CUP11911)					
R632	CRD25FJ180T	RES , CARBON	18 OHM 1/4W	1	EA
R633	CRD25FJ180T	RES , CARBON	18 OHM 1/4W	1	EA
R634	CRD25FJ180T	RES , CARBON	18 OHM 1/4W	1	EA
R635	CRD25FJ180T	RES , CARBON	18 OHM 1/4W	1	EA
R636	CRD25FJ180T	RES , CARBON	18 OHM 1/4W	1	EA
R637	CRD25FJ180T	RES , CARBON	18 OHM 1/4W	1	EA
R638	CRD25FJ180T	RES , CARBON	18 OHM 1/4W	1	EA
R639	CRD25FJ180T	RES , CARBON	18 OHM 1/4W	1	EA
R640	CRD25FJ180T	RES , CARBON	18 OHM 1/4W	1	EA
R646	CRD25FJ3R3T	RES , CARBON	3.3 OHM 1/4W J	1	EA
R647	CRD25FJ3R3T	RES , CARBON	3.3 OHM 1/4W J	1	EA
R648	CRD25FJ3R3T	RES , CARBON	3.3 OHM 1/4W J	1	EA
R649	CRD25FJ3R3T	RES , CARBON	3.3 OHM 1/4W J	1	EA
R650	CRD25FJ3R3T	RES , CARBON	3.3 OHM 1/4W J	1	EA
R651	CRD25FJ3R3T	RES , CARBON	3.3 OHM 1/4W J	1	EA
R652	CRD25FJ3R3T	RES , CARBON	3.3 OHM 1/4W J	1	EA
R653	CRD25FJ3R3T	RES , CARBON	3.3 OHM 1/4W J	1	EA
R654	CRD25FJ3R3T	RES , CARBON	3.3 OHM 1/4W J	1	EA
R655	CRD25FJ3R3T	RES , CARBON	3.3 OHM 1/4W J	1	EA
R666	CRD25TJ470T	RES , CARBON	47 OHM 1/4W	1	EA
R667	CRD25TJ470T	RES , CARBON	47 OHM 1/4W	1	EA
R668	CRD25TJ470T	RES , CARBON	47 OHM 1/4W	1	EA
R669	CRD25TJ470T	RES , CARBON	47 OHM 1/4W	1	EA
R670	CRD25TJ470T	RES , CARBON	47 OHM 1/4W	1	EA
R671	CRD20TJ911T	RES , CARBON	910 OHM 1/5W J	1	EA
R672	CRD20TJ911T	RES , CARBON	910 OHM 1/5W J	1	EA
R673	CRD20TJ911T	RES , CARBON	910 OHM 1/5W J	1	EA
R674	CRD20TJ911T	RES , CARBON	910 OHM 1/5W J	1	EA
R675	CRD20TJ911T	RES , CARBON	910 OHM 1/5W J	1	EA
R676	CRD20TJ182T	RES , CARBON	1.8K OHM 1/5W J	1	EA
R677	CRD20TJ182T	RES , CARBON	1.8K OHM 1/5W J	1	EA
R678	CRD20TJ182T	RES , CARBON	1.8K OHM 1/5W J	1	EA
R679	CRD20TJ182T	RES , CARBON	1.8K OHM 1/5W J	1	EA
R680	CRD20TJ182T	RES , CARBON	1.8K OHM 1/5W J	1	EA
R681	CRD20TJ562T	RES , CARBON	5.6K OHM 1/5W J	1	EA
R682	CRD20TJ562T	RES , CARBON	5.6K OHM 1/5W J	1	EA
R683	CRD20TJ562T	RES , CARBON	5.6K OHM 1/5W J	1	EA
R684	CRD20TJ562T	RES , CARBON	5.6K OHM 1/5W J	1	EA
R685	CRD20TJ562T	RES , CARBON	5.6K OHM 1/5W J	1	EA
R686	CRD20TJ103T	RES , CARBON	10K OHM 1/5W J	1	EA
R687	CRD20TJ103T	RES , CARBON	10K OHM 1/5W J	1	EA
R688	CRD20TJ103T	RES , CARBON	10K OHM 1/5W J	1	EA
R689	CRD20TJ103T	RES , CARBON	10K OHM 1/5W J	1	EA
R690	CRD20TJ103T	RES , CARBON	10K OHM 1/5W J	1	EA
R696	CRD25TJ470T	RES , CARBON	47 OHM 1/4W	1	EA
R697	CRD25TJ470T	RES , CARBON	47 OHM 1/4W	1	EA
R698	CRD25TJ470T	RES , CARBON	47 OHM 1/4W	1	EA
R699	CRD25TJ470T	RES , CARBON	47 OHM 1/4W	1	EA
R700	CRD25TJ470T	RES , CARBON	47 OHM 1/4W	1	EA
R701	C3A206	WIRE , COPPER	SN95/PB5 , 0.6		
R702	C3A206	WIRE , COPPER	SN95/PB5 , 0.6		
R703	C3A206	WIRE , COPPER	SN95/PB5 , 0.6		
R704	C3A206	WIRE , COPPER	SN95/PB5 , 0.6		
R705	C3A206	WIRE , COPPER	SN95/PB5 , 0.6		
R706	C3A206	WIRE , COPPER	SN95/PB5 , 0.6		
R707	C3A206	WIRE , COPPER	SN95/PB5 , 0.6		
R708	C3A206	WIRE , COPPER	SN95/PB5 , 0.6		
R771	CRD20TJ750T	RES , CARBON	75 OHM 1/5W J	1	EA
R772	CRD20TJ750T	RES , CARBON	75 OHM 1/5W J	1	EA
R773	CRD20TJ750T	RES , CARBON	75 OHM 1/5W J	1	EA
R774	CRD20TJ750T	RES , CARBON	75 OHM 1/5W J	1	EA

Ref. Designator	Part Number	Description		Qty	
MAIN PCB (CUP11911)					
R775	CRD20TJ750T	RES , CARBON	75 OHM 1/5W J	1	EA
R776	CRD20TJ750T	RES , CARBON	75 OHM 1/5W J	1	EA
R777	CRD20TJ750T	RES , CARBON	75 OHM 1/5W J	1	EA
R781	CRD20TJ750T	RES , CARBON	75 OHM 1/5W J	1	EA
R782	CRD20TJ750T	RES , CARBON	75 OHM 1/5W J	1	EA
R783	CRD20TJ750T	RES , CARBON	75 OHM 1/5W J	1	EA
R784	CRD20TJ750T	RES , CARBON	75 OHM 1/5W J	1	EA
R785	CRD20TJ750T	RES , CARBON	75 OHM 1/5W J	1	EA
R786	CRD20TJ750T	RES , CARBON	75 OHM 1/5W J	1	EA
R787	CRD20TJ750T	RES , CARBON	75 OHM 1/5W J	1	EA
R801	CRD20TJ103T	RES , CARBON	10K OHM 1/5W J	1	EA
R802	CRD20TJ103T	RES , CARBON	10K OHM 1/5W J	1	EA
R803	CRD20TJ562T	RES , CARBON	5.6K OHM 1/5W J	1	EA
R804	CRD20TJ562T	RES , CARBON	5.6K OHM 1/5W J	1	EA
R805	CRD20TJ911T	RES , CARBON	910 OHM 1/5W J	1	EA
R807	CRD20TJ911T	RES , CARBON	910 OHM 1/5W J	1	EA
R808	CRD20TJ182T	RES , CARBON	1.8K OHM 1/5W J	1	EA
R809	CRD20TJ182T	RES , CARBON	1.8K OHM 1/5W J	1	EA
R812	CRD25TJ470T	RES , CARBON	47 OHM 1/4W	1	EA
R813	CRD25TJ470T	RES , CARBON	47 OHM 1/4W	1	EA
R814	CRD25TJ470T	RES , CARBON	47 OHM 1/4W	1	EA
R815	CRD25TJ470T	RES , CARBON	47 OHM 1/4W	1	EA
R817	CRD25FJ3R3T	RES , CARBON	3.3 OHM 1/4W J	1	EA
R818	CRD25FJ3R3T	RES , CARBON	3.3 OHM 1/4W J	1	EA
R819	CRD25FJ3R3T	RES , CARBON	3.3 OHM 1/4W J	1	EA
R820	CRD25FJ3R3T	RES , CARBON	3.3 OHM 1/4W J	1	EA
R821	CRD25FJ180T	RES , CARBON	18 OHM 1/4W	1	EA
R822	CRD25FJ180T	RES , CARBON	18 OHM 1/4W	1	EA
R823	CRD25FJ180T	RES , CARBON	18 OHM 1/4W	1	EA
R824	CRD25FJ180T	RES , CARBON	18 OHM 1/4W	1	EA
R830	CRD20TJ223T	RES , CARBON	22K OHM 1/5W J	1	EA
R831	CRD20TJ223T	RES , CARBON	22K OHM 1/5W J	1	EA
R832	CRD20TJ223T	RES , CARBON	22K OHM 1/5W J	1	EA
R833	CRD20TJ223T	RES , CARBON	22K OHM 1/5W J	1	EA
R834	CRD20TJ561T	RES , CARBON	560 OHM 1/5W J	1	EA
R835	CRD20TJ561T	RES , CARBON	560 OHM 1/5W J	1	EA
R836	CRD20TJ561T	RES , CARBON	560 OHM 1/5W J	1	EA
R837	CRD20TJ561T	RES , CARBON	560 OHM 1/5W J	1	EA
R838	CRD20TJ561T	RES , CARBON	560 OHM 1/5W J	1	EA
R839	CRD20TJ561T	RES , CARBON	560 OHM 1/5W J	1	EA
R840	CRD20TJ561T	RES , CARBON	560 OHM 1/5W J	1	EA
R841	CRD20TJ561T	RES , CARBON	560 OHM 1/5W J	1	EA
R842	CRD20TJ561T	RES , CARBON	560 OHM 1/5W J	1	EA
R843	CRD20TJ561T	RES , CARBON	560 OHM 1/5W J	1	EA
R844	CRD20TJ561T	RES , CARBON	560 OHM 1/5W J	1	EA
R845	CRD20TJ561T	RES , CARBON	560 OHM 1/5W J	1	EA
R848	CRD20TJ273T	RES , CARBON	27K OHM 1/5W J	1	EA
R849	CRD20TJ273T	RES , CARBON	27K OHM 1/5W J	1	EA
R850	CRD20TJ162T	RES , CARBON	1.6K OHM 1/5W J	1	EA
R851	CRD20TJ162T	RES , CARBON	1.6K OHM 1/5W J	1	EA
R852	CRD20TJ152T	RES , CARBON	1.5K OHM 1/5W J	1	EA
R853	CRD20TJ152T	RES , CARBON	1.5K OHM 1/5W J	1	EA
R854	CRD20TJ152T	RES , CARBON	1.5K OHM 1/5W J	1	EA
R855	CRD20TJ152T	RES , CARBON	1.5K OHM 1/5W J	1	EA
R856	CRD20TJ221T	RES , CARBON	220 OHM 1/5W J	1	EA
R857	CRD20TJ221T	RES , CARBON	220 OHM 1/5W J	1	EA
R858	CRD20TJ221T	RES , CARBON	220 OHM 1/5W J	1	EA
R859	CRD20TJ221T	RES , CARBON	220 OHM 1/5W J	1	EA
R860	CRD20TJ271T	RES , CARBON	270 OHM 1/5W J	1	EA
R861	CRD20TJ271T	RES , CARBON	270 OHM 1/5W J	1	EA
R862	CRD20TJ333T	RES , CARBON	33K OHM 1/5W J	1	EA

Ref. Designator	Part Number	Description		Qty	
MAIN PCB (CUP11911)					
R863	CRD20TJ333T	RES , CARBON	33K OHM 1/5W J	1	EA
R870	CRD20TJ433T	RES , CARBON	43K OHM 1/5W J	1	EA
R871	CRD20TJ433T	RES , CARBON	43K OHM 1/5W J	1	EA
R872	CRD20TJ471T	RES , CARBON	470 OHM 1/5W J	1	EA
R873	CRD20TJ471T	RES , CARBON	470 OHM 1/5W J	1	EA
R900	CRD20TJ103T	RES , CARBON	10K OHM 1/5W J	1	EA
R901	CRD25TJ393T	RES , CARBON	39K OHM 1/4W	1	EA
R902	CRD25TJ393T	RES , CARBON	39K OHM 1/4W	1	EA
R903	CRD25TJ393T	RES , CARBON	39K OHM 1/4W	1	EA
R906	CRD25TJ393T	RES , CARBON	39K OHM 1/4W	1	EA
R907	CRD20TJ103T	RES , CARBON	10K OHM 1/5W J	1	EA
R908	CRD20TJ105T	RES , CARBON	1M OHM 1/5W J	1	EA
R909	CRD20TJ682T	RES , CARBON	6.8K OHM 1/5W J	1	EA
R910	CRD20TJ105T	RES , CARBON	1M OHM 1/5W J	1	EA
R911	CRD25TJ680T	RES , CARBON	68 OHM 1/4W J	1	EA
R912	CRD20TJ332T	RES , CARBON	3.3K OHM 1/5W J	1	EA
R917	CRD25TJ393T	RES , CARBON	39K OHM 1/4W	1	EA
R918	CRD25TJ393T	RES , CARBON	39K OHM 1/4W	1	EA
R919	CRD25TJ393T	RES , CARBON	39K OHM 1/4W	1	EA
R920	CRD25TJ393T	RES , CARBON	39K OHM 1/4W	1	EA
R921	CRD25FJ180T	RES , CARBON	18 OHM 1/4W J	1	EA
R922	CRD25TJ470T	RES , CARBON	47 OHM 1/4W J	1	EA
R923	CRD20TJ220T	RES , CARBON	22 OHM 1/5W J	1	EA
R924	CRD20TJ473T	RES , CARBON	47K OHM 1/5W J	1	EA
R925	CRD20TJ473T	RES , CARBON	47K OHM 1/5W J	1	EA
R926	CRD20TJ473T	RES , CARBON	47K OHM 1/5W J	1	EA
R927	CRD20TJ473T	RES , CARBON	47K OHM 1/5W J	1	EA
R928	CRD20TJ222T	RES , CARBON	2.2K OHM 1/5W J	1	EA
R929	CRD20TJ222T	RES , CARBON	2.2K OHM 1/5W J	1	EA
R930	CRD20TJ222T	RES , CARBON	2.2K OHM 1/5W J	1	EA
R931	CRD20TJ222T	RES , CARBON	2.2K OHM 1/5W J	1	EA
R932	CRD20TJ103T	RES , CARBON	10K OHM 1/5W J	1	EA
R933	CRD20TJ472T	RES , CARBON	4.7K OHM 1/5W J	1	EA
R934	CRD20TJ104T	RES , CARBON	100K OHM 1/5W J	1	EA
R935	CRD20TJ154T	RES , CARBON	100K OHM 1/5W J	1	EA
R936	CRD20TJ184T	RES , CARBON	150K OHM 1/5W J	1	EA
R939	CRD20TJ472T	RES , CARBON	4.7K OHM 1/5W J	1	EA
R940	CRD20TJ152T	RES , CARBON	1.5K OHM 1/5W J	1	EA
R941	CRD20TJ223T	RES , CARBON	22K OHM 1/5W J	1	EA
R942	CRD20TJ223T	RES , CARBON	22K OHM 1/5W J	1	EA
R943	CRD20TJ223T	RES , CARBON	22K OHM 1/5W J	1	EA
R944	CRD25TJ223T	RES , CARBON	22K OHM 1/4W J	1	EA
R945	CRD20TJ223T	RES , CARBON	22K OHM 1/5W J	1	EA
R946	CRD25TJ223T	RES , CARBON	22K OHM 1/4W J	1	EA
R947	CRD20TJ223T	RES , CARBON	22K OHM 1/5W J	1	EA
R948	CRD25TJ222T	RES , CARBON	2.2K OHM 1/4W J	1	EA
R949	CRD20TJ822T	RES , CARBON	8.2K OHM 1/5W J	1	EA
R952	CRD25TJ223T	RES , CARBON	22K OHM 1/4W J	1	EA
R953	CRD20TJ223T	RES , CARBON	22K OHM 1/5W J	1	EA
R954	CRD20TJ223T	RES , CARBON	22K OHM 1/5W J	1	EA
R955	CRD20TJ203T	RES , CARBON	20K OHM 1/5W J	1	EA
R956	CRD20TJ394T	RES , CARBON	390K OHM 1/5W J	1	EA
R957	CRD20TJ153T	RES , CARBON	15K OHM 1/5W J	1	EA
R958	CRD20TJ563T	RES , CARBON	56K OHM 1/5W J	1	EA
R959	CRD20TJ104T	RES , CARBON	100K OHM 1/5W J	1	EA
R960	CRD20TJ332T	RES , CARBON	3.3K OHM 1/5W J	1	EA
R961	CRD20TJ331T	RES , CARBON	330 OHM 1/5W J	1	EA
R962	CRD20TJ273T	RES , CARBON	27K OHM 1/5W J	1	EA
R963	CRD20TJ105T	RES , CARBON	1M OHM 1/5W J	1	EA
R966	CRD20TJ472T	RES , CARBON	4.7K OHM 1/5W J	1	EA
R967	CRD20TJ562T	RES , CARBON	5.6K OHM 1/5W J	1	EA

Ref. Designator	Part Number	Description		Qty	
MAIN PCB (CUP11911)					
R968	CRD20TJ105T	RES , CARBON	1M OHM 1/5W J	1	EA
R969	CRD20TJ103T	RES , CARBON	10K OHM 1/5W J	1	EA
R980	CRD20TJ473T	RES , CARBON	47K OHM 1/5W J	1	EA
R986	CRD20TJ102T	RES , CARBON	1K OHM 1/5W J	1	EA
R987	CRD20TJ561T	RES , CARBON	560 OHM 1/5W J	1	EA
R988	CRD20TJ562T	RES , CARBON	5.6K OHM 1/5W J	1	EA
R989	CRD20TJ302T	RES , CARBON	3K OHM 1/5W J	1	EA
R991	CRD20TJ822T	RES , CARBON	8.2K OHM 1/5W J	1	EA
R992	CRD20TJ562T	RES , CARBON	5.6K OHM 1/5W J	1	EA
R998	CRD20TJ103T	RES , CARBON	10K OHM 1/5W J	1	EA
R656	CRF5EKR27HX2K	RES , CEMENT	0.27ohm X 2	1	EA
R657	CRF5EKR27HX2K	RES , CEMENT	0.27ohm X 2	1	EA
R658	CRF5EKR27HX2K	RES , CEMENT	0.27ohm X 2	1	EA
R659	CRF5EKR27HX2K	RES , CEMENT	0.27ohm X 2	1	EA
R660	CRF5EKR27HX2K	RES , CEMENT	0.27ohm X 2	1	EA
R810	CRF5EKR27HX2K	RES , CEMENT	0.27ohm X 2	1	EA
R811	CRF5EKR27HX2K	RES , CEMENT	0.27ohm X 2	1	EA
R904	HRDERC12UGK335T	RES , CARBON	ERC12UGK 3.3M OHM	1	EA
R905	CRG1ANJ100H	RES , METAL OXIDE FILM	10 OHM 1W J	1	EA
R990	CRG1ANJ100H	RES , METAL OXIDE FILM	10 OHM 1W J	1	EA
R993	CRG1ANJ100H	RES , METAL OXIDE FILM	10 OHM 1W J	1	EA
R994	CRG1ANJ100H	RES , METAL OXIDE FILM	10 OHM 1W J	1	EA
R995	CRG1ANJ100H	RES , METAL OXIDE FILM	10 OHM 1W J	1	EA
R996	CRG1ANJ100H	RES , METAL OXIDE FILM	10 OHM 1W J	1	EA
R997	CRG1ANJ100H	RES , METAL OXIDE FILM	10 OHM 1W J	1	EA
R999	CRG1ANJ100H	RES , METAL OXIDE FILM	10 OHM 1W J	1	EA
<i>Miscellaneous</i>					
BN19	CWB3FE03250UP	WIRE ASS'Y	WIRE	1	EA
BN20	CWB3FC04280UP	WIRE ASS'Y	WIRE	1	EA
BN81	CWB1C902050EN	WIRE ASS'Y	WIRE	1	EA
BN82	CWB1C902050EN	WIRE ASS'Y	WIRE	1	EA
BN83	CWB1C902050EN	WIRE ASS'Y	WIRE	1	EA
BN84	CWB1C902050EN	WIRE ASS'Y	WIRE	1	EA
BN85	CWB1C902050EN	WIRE ASS'Y	WIRE	1	EA
BN86	CWB1C902050EN	WIRE ASS'Y	WIRE	1	EA
BN87	CWB1C902050EN	WIRE ASS'Y	WIRE	1	EA
BN88	CWB2B906070EN	WIRE ASS'Y	WIRE	1	EA
BN89	CWB1C902250BM	WIRE ASS'Y	WIRE	1	EA
BN90	CWB4F232550PU	WIRE ASS'Y	WIRE	1	EA
BN97	CWZAVR340BN97	WIRE ASS'Y	WIRE	1	EA
BN98	HJP08GA130ZK	WAFER	WAFER	1	EA
CN11	CJP17GA117ZY	WAFER	WAFER	1	EA
CN12	CJP21GA115ZY	WAFER , CARD CABLE	WAFER	1	EA
CN61	CJP02GA01ZY	WAFER, STRAIGHT, 2PIN	WAFER	1	EA
CN62	CJP02GA01ZY	WAFER, STRAIGHT, 2PIN	WAFER	1	EA
CN63	CJP02GA01ZY	WAFER, STRAIGHT, 2PIN	WAFER	1	EA
CN64	CJP02GA01ZY	WAFER, STRAIGHT, 2PIN	WAFER	1	EA
CN65	CJP02GA01ZY	WAFER, STRAIGHT, 2PIN	WAFER	1	EA
CN66	CJP02GA01ZY	WAFER, STRAIGHT, 2PIN	WAFER	1	EA
CN67	CJP02GA01ZY	WAFER, STRAIGHT, 2PIN	WAFER	1	EA
CN89	CJP02GA01ZY	WAFER, STRAIGHT, 2PIN	WAFER	1	EA
CN91	CJP02GA89ZY	WAFER	WAFER	1	EA
CN92	KJP02KA060ZY	WAFER	WAFER	1	EA
CN93	CJP02GA01ZY	WAFER, STRAIGHT, 2PIN	WAFER	1	EA
ET90	HJT1A025	PLATE , EARTH	MET37-0002	1	EA
ET91	HJT1A025	PLATE , EARTH	MET37-0002	1	EA
F901	KJCF5S	HOLDER , FUSE	HOLDER	2	EA
F902	KBA2D2500TLET	FUSE (SR-5,2.5A,250V)	SAVE FUSETECH	1	EA
ET01	CMD1A387	BRACKET , PCB	BRACKET	1	EA

Ref. Designator	Part Number	Description		Qty	
MAIN PCB (CUP11911)					
JK91	CJJ5R006Z	TERMINAL , SPEAKER	TERMINAL	1	EA
JK92	CJJ5Q012Z	TERMINAL , SPEAKER	TERMINAL	1	EA
JK97	CJJ4P041W	JACK IN/OUT	JACK	1	EA
JK98	CJJ4P042W	JACK IN/OUT	JACK	1	EA
JW90	CWE8212120VV	WIRE , RED	WIRE	1	EA
JW91	CWE8212180VV	WIRE ASS'Y	WIRE	1	EA
JW93	CWEP202110VV	WIRE	WIRE	1	EA
L501	CLEY0R5KAK	COIL , SPEAKER	0.5UH K	1	EA
L502	CLEY0R5KAK	COIL , SPEAKER	0.5UH K	1	EA
L503	CLEY0R5KAK	COIL , SPEAKER	0.5UH K	1	EA
L504	CLEY0R5KAK	COIL , SPEAKER	0.5UH K	1	EA
L505	CLEY0R5KAK	COIL , SPEAKER	0.5UH K	1	EA
L506	CLEY0R5KAK	COIL , SPEAKER	0.5UH K	1	EA
L507	CLEY0R5KAK	COIL , SPEAKER	0.5UH K	1	EA
OL91	KJJ7A013Z	AC OUTLET , 1PIN USA	A202D0031P(1P)	1	EA
RY94	HSL1A008ZE	RELAY(+12VDC)	SDT-S-112DMR(OEG)	1	EA
TH91	KRTP42T7D330B	THERMAL SENSOR , POSISTOR	P42T7D330BW20	1	EA
T902	CLT5J038ZU	TRANS , SUB	TRANS	1	EA
HEAT SINK ASS'Y					
	CFNCF12825MS	MOTOR, FAN(80*80*25MM)	FAN	1	EA
	CHD1A012R	SCREW , SPECIAL	SCREW	21	EA
	CHD1A036R	SCREW , SPECIAL	SCREW	4	EA
	CHD3A012R	SCREW , SPECIAL	SCREW	5	EA
	CMD1A398	BRACKET , PCB	BRACKET	2	EA
	CMD1A417	BRACKET , PCB	BRACKET	2	EA
	CMD1A600	BRACKET , FAN	BRACKET	1	EA
	CMY1A270	HEAT SINK	HEAT SINK	1	EA
	CMY2A249	HEAT SINK	HEAT SINK	1	EA
	CTB3+10JR	SCREW	SCREW	3	EA
	CTB3+8JR	SCREW	SCREW	6	EA
Q652	HVT2SB1647-OKM	TRANSISTOR, PNP, POWER	2SB1647	1	EA
Q653	HVT2SB1647-OKM	TRANSISTOR, PNP, POWER	2SB1647	1	EA
Q654	HVT2SB1647-OKM	TRANSISTOR, PNP, POWER	2SB1647	1	EA
Q655	HVT2SB1647-OKM	TRANSISTOR, PNP, POWER	2SB1647	1	EA
Q657	HVT2SD2560-OKM	TRANSISTOR, NPN, POWER	2SD2560	1	EA
Q658	HVT2SD2560-OKM	TRANSISTOR, NPN, POWER	2SD2560	1	EA
Q659	HVT2SD2560-OKM	TRANSISTOR, NPN, POWER	2SD2560	1	EA
Q660	HVT2SD2560-OKM	TRANSISTOR, NPN, POWER	2SD2560	1	EA
Q661	HVT2SB1647-OKM	TRANSISTOR, PNP, POWER	2SB1647	1	EA
Q670	HVT2SD2560-OKM	TRANSISTOR, NPN, POWER	2SD2560	1	EA
Q803	HVT2SD2560-OKM	TRANSISTOR, NPN, POWER	2SD2560	1	EA
Q804	HVT2SB1647-OKM	TRANSISTOR, PNP, POWER	2SB1647	1	EA
Q805	HVT2SD2560-OKM	TRANSISTOR, NPN, POWER	2SD2560	1	EA
Q807	HVT2SB1647-OKM	TRANSISTOR, PNP, POWER	2SB1647	1	EA
	CFNCF12825MS	MOTOR, FAN(80*80*25MM)	FAN	1	EA
	CHD1A036R	SCREW , SPECIAL	SCREW	2	EA
	CHD3A012R	SCREW , SPECIAL	SCREW	3	EA
	CMD1A615	BRACKET , FAN	BRACKET	1	EA
	CTW3+8JR	SCREW	SCREW	2	EA
BIAS PCB (CUP11916-2)					
<i>Capacitors</i>					
C851	CCEA1HH100T	CAP , ELECT	10UF 50V	1	EA
C852	CCEA1HH100T	CAP , ELECT	10UF 50V	1	EA
C853	CCEA1HH100T	CAP , ELECT	10UF 50V	1	EA
C854	CCEA1HH100T	CAP , ELECT	10UF 50V	1	EA
C855	CCEA1HH100T	CAP , ELECT	10UF 50V	1	EA

Ref. Designator	Part Number	Description		Qty	
BIAS PCB (CUP11916-2)					
C856	CCEA1HH100T	CAP , ELECT	10UF 50V	1	EA
C857	CCEA1HH100T	CAP , ELECT	10UF 50V	1	EA
<i>Semiconductors</i>					
Q851	HVTKTD600KGR	TRANSISTOR , BIAS NPN	KTD600KGR	1	EA
Q852	HVTKTD600KGR	TRANSISTOR , BIAS NPN	KTD600KGR	1	EA
Q853	HVTKTD600KGR	TRANSISTOR , BIAS NPN	KTD600KGR	1	EA
Q854	HVTKTD600KGR	TRANSISTOR , BIAS NPN	KTD600KGR	1	EA
Q855	HVTKTD600KGR	TRANSISTOR , BIAS NPN	KTD600KGR	1	EA
Q856	HVTKTD600KGR	TRANSISTOR , BIAS NPN	KTD600KGR	1	EA
Q857	HVTKTD600KGR	TRANSISTOR , BIAS NPN	KTD600KGR	1	EA
<i>Resistors</i>					
R874	CRD20TJ331T	RES , CARBON	330 OHM 1/5W J	1	EA
R875	CRD20TJ331T	RES , CARBON	330 OHM 1/5W J	1	EA
R876	CRD20TJ331T	RES , CARBON	330 OHM 1/5W J	1	EA
R877	CRD20TJ331T	RES , CARBON	330 OHM 1/5W J	1	EA
R878	CRD20TJ331T	RES , CARBON	330 OHM 1/5W J	1	EA
R879	CRD20TJ331T	RES , CARBON	330 OHM 1/5W J	1	EA
R880	CRD20TJ331T	RES , CARBON	330 OHM 1/5W J	1	EA
R882	CRD20TJ122T	RES , CARBON	1.2K OHM 1/5W J	1	EA
R883	CRD20TJ122T	RES , CARBON	1.2K OHM 1/5W J	1	EA
R884	CRD20TJ122T	RES , CARBON	1.2K OHM 1/5W J	1	EA
R885	CRD20TJ122T	RES , CARBON	1.2K OHM 1/5W J	1	EA
R886	CRD20TJ122T	RES , CARBON	1.2K OHM 1/5W J	1	EA
R887	CRD20TJ122T	RES , CARBON	1.2K OHM 1/5W J	1	EA
R888	CRD20TJ122T	RES , CARBON	1.2K OHM 1/5W J	1	EA
VR81	HVN1RA221B01T	RES , SEMI FIXED(220 OHM)	RH0615C100221	1	EA
VR82	HVN1RA221B01T	RES , SEMI FIXED(220 OHM)	RH0615C100221	1	EA
VR83	HVN1RA221B01T	RES , SEMI FIXED(220 OHM)	RH0615C100221	1	EA
VR84	HVN1RA221B01T	RES , SEMI FIXED(220 OHM)	RH0615C100221	1	EA
VR85	HVN1RA221B01T	RES , SEMI FIXED(220 OHM)	RH0615C100221	1	EA
VR86	HVN1RA221B01T	RES , SEMI FIXED(220 OHM)	RH0615C100221	1	EA
VR87	HVN1RA221B01T	RES , SEMI FIXED(220 OHM)	RH0615C100221	1	EA
<i>Miscellaneous</i>					
CN31	CJP02GA19ZY	WAFER, 2PIN	WAFER	1	EA
CN32	CJP02GA19ZY	WAFER, 2PIN	WAFER	1	EA
CN33	CJP02GA19ZY	WAFER, 2PIN	WAFER	1	EA
CN34	CJP02GA19ZY	WAFER, 2PIN	WAFER	1	EA
CN35	CJP02GA19ZY	WAFER, 2PIN	WAFER	1	EA
CN36	CJP02GA19ZY	WAFER, 2PIN	WAFER	1	EA
CN37	CJP02GA19ZY	WAFER, 2PIN	WAFER	1	EA
REGULATOR PCB (CUP11916-5)					
C935	HCBS1H223ZFT	CAP , CERAMIC	0.022UF 50V	1	EA
C936	HCBS1H223ZFT	CAP , CERAMIC	0.022UF 50V	1	EA
C937	HCBS1H223ZFT	CAP , CERAMIC	0.022UF 50V	1	EA
C938	CCEA1CH101T	CAP , ELECT	100UF 16V	1	EA
C939	CCEA1EH101T	CAP , ELECT	100UF 25V	1	EA
C940	CCEA1EH101T	CAP , ELECT	100UF 25V	1	EA
CN96	CJP09GA01ZY	CON WAFER YMW025-09R	WAFER	1	EA
CN98	HJP08GB131ZK	WAFER	WAFER	1	EA
BN20	CWB1C905220BM	WIRE ASS'Y	WIRE	1	EA
BN95	CWB1C903080EN	WIRE ASS'Y	WIRE	1	EA
C912	CCEA0JKR3222E	CAP , ELECT	2200UF 6.3V	1	EA

Ref. Designator	Part Number	Description		Qty	
REGULATOR PCB (CUP11916-5)					
C929	CCEA1VH102E	CAP , ELECT	1000UF 35V	1	EA
C930	CCEA1VH102E	CAP , ELECT	1000UF 35V	1	EA
IC89	HVIL7805CP	I.C, REGULATOR(+5V)	ST	1	EA
IC90	HVIL7815CP	I.C, REGULATOR(+15V)	ST	1	EA
IC91	HVIL7915CP	I.C, REGULATOR(-15V)	ST	1	EA
POWER TRANS PCB(CUP11916-3,4)					
<i>Capacitors</i>					
C104	HCBS1H103ZFT	CAP , CERAMIC	0.01UF 50V	1	EA
C105	HCBS1H103ZFT	CAP , CERAMIC	0.01UF 50V	1	EA
C106	CCFT1H104ZF	CAP , SEMICONDUCTOR	0.1UF 50V ZF	1	EA
C107	HCBS1H103ZFT	CAP , CERAMIC	0.01UF 50V	1	EA
C108	HCBS1H103ZFT	CAP , CERAMIC	0.01UF 50V	1	EA
C109	CCFT1H104ZF	CAP , SEMICONDUCTOR	0.1UF 50V ZF	1	EA
C117	CCEA1HH4R7T	CAP , ELECT	4.7UF 50V	1	EA
C118	HCBS1H103ZFT	CAP , CERAMIC	0.01UF 50V	1	EA
C119	CCEA1JH470TS	CAP , ELECT	47UF 63V	1	EA
C120	CCEA1JH470TS	CAP , ELECT	47UF 63V	1	EA
C121	HCBS1H103ZFT	CAP , CERAMIC	0.01UF 50V	1	EA
C123	CCFT1H473ZF	CAP , CERAMIC	0.047UF 50V ZF	1	EA
C125	CCFT1H473ZF	CAP , CERAMIC	0.047UF 50V ZF	1	EA
C126	CCFT1H473ZF	CAP , CERAMIC	0.047UF 50V ZF	1	EA
C127	CCFT1H473ZF	CAP , CERAMIC	0.047UF 50V ZF	1	EA
C131	CCEA1HH4R7T	CAP , ELECT	4.7UF 50V	1	EA
C919	CCKT1H102KB	CAP , CERAMIC	1000PF 50V	1	EA
C920	CCEA1HH470T	CAP , ELECT	47UF 50V	1	EA
C921	HCQI1H104JZT	CAP , MYLAR	0.1UF 50V J	1	EA
C922	HCQI1H104JZT	CAP , MYLAR	0.1UF 50V J	1	EA
C923	HCQI1H104JZT	CAP , MYLAR	0.1UF 50V J	1	EA
C924	HCQI1H104JZT	CAP , MYLAR	0.1UF 50V J	1	EA
C925	HCQI1H103JZT	CAP , MYLAR	0.01UF 50V J	1	EA
C926	HCQI1H103JZT	CAP , MYLAR	0.01UF 50V J	1	EA
C927	HCQI1H103JZT	CAP , MYLAR	0.01UF 50V J	1	EA
C928	HCQI1H103JZT	CAP , MYLAR	0.01UF 50V J	1	EA
C931	HCQI1H473JZT	CAP , MYLAR	0.047UF 50V J	1	EA
C932	HCQI1H473JZT	CAP , MYLAR	0.047UF 50V J	1	EA
C933	HCQI1H473JZT	CAP , MYLAR	0.047UF 50V J	1	EA
C934	HCQI1H473JZT	CAP , MYLAR	0.047UF 50V J	1	EA
C947	CCFT1H104ZF	CAP , SEMICONDUCTOR	0.1UF 50V ZF	1	EA
C948	CCFT1H103ZF	CAP , CERAMIC	0.01UF 50V	1	EA
C949	CCFT1H103ZF	CAP , CERAMIC	0.01UF 50V	1	EA
C122	CCEA1JH101E	CAP , ELECT	100UF 63V	1	EA
C124	CCEA1VH102E	CAP , ELECT	1000UF 35V	1	EA
C128	CCEA1EH102E	CAP , ELECT	1000UF 25V	1	EA
C129	CCEA1EH222E	CAP , ELECT	2200UF 25V	1	EA
C130	CCEA1EH102E	CAP , ELECT	1000UF 25V	1	EA
C132	CCEA1VH472F	CAP , ELECT	4700UF 35V	1	EA
C941	CCEA1CH682E	CAP , ELECT	6800UF 16V	1	EA
C951	CCEA1HH102E	CAP , ELECT	1000UF/50V	1	EA
<i>Semiconductors</i>					
D101	HVDMTZJ15BT	DIODE , ZENER	MTZJ15B 1/2W	1	EA
D102	HVDMTZJ27BT	DIODE , ZENER	MTZJ27B 1/2W	1	EA
D104	CVD1N4003ST	RECT , DIODE	1N4003	1	EA
D105	CVD1N4003ST	RECT , DIODE	1N4003	1	EA
D108	CVD1N4003ST	RECT , DIODE	1N4003	1	EA
D109	HVDMTZJ12BT	DIODE , ZENER	MTZJ12B 1/2W	1	EA
D111	HVDMTZJ12BT	DIODE , ZENER	MTZJ12B 1/2W	1	EA

Ref. Designator	Part Number	Description		Qty	
POWER TRANS PCB(CUP11916-3,4)					
D112	CVD1N4003ST	RECT , DIODE	1N4003	1	EA
D113	CVD1N4003ST	RECT , DIODE	1N4003	1	EA
D114	CVD1N4003ST	RECT , DIODE	1N4003	1	EA
D115	CVD1N4003ST	RECT , DIODE	1N4003	1	EA
D116	CVD1N4003ST	RECT , DIODE	1N4003	1	EA
D117	CVD1N4003ST	RECT , DIODE	1N4003	1	EA
D118	CVD1N4003ST	RECT , DIODE	1N4003	1	EA
D119	CVD1N4003ST	RECT , DIODE	1N4003	1	EA
D120	CVD1N4003ST	RECT , DIODE	1N4003	1	EA
D121	CVD1N4003ST	RECT , DIODE	1N4003	1	EA
D122	CVD1N4003ST	RECT , DIODE	1N4003	1	EA
D123	CVD1N4003ST	RECT , DIODE	1N4003	1	EA
D124	CVD1N4003ST	RECT , DIODE	1N4003	1	EA
D125	CVD1N4003ST	RECT , DIODE	1N4003	1	EA
D922	HVDMTZJ3.3BT	DIODE , ZENER	MTZJ3.3B 1/2W	1	EA
D950	CVD1N4003ST	RECT , DIODE	1N4003	1	EA
D951	CVD1N4003ST	RECT , DIODE	1N4003	1	EA
Q104	HVTKSC2316YT	TRANSISTOR NPN	KSC2316Y	1	EA
Q911	HVTKTA1267YT	TRANSISTOR PNP	KTA1267Y	1	EA
Q912	HVTKTC3198YT	TRANSISTOR NPN	KTC3198Y	1	EA
Q913	HVTKTC3198YT	TRANSISTOR NPN	KTC3198Y	1	EA
D992	CVDKBU804FMA	BRIDGE DIODE ASS'Y	ASS'Y	1	EA
D991	CVDKBU804FMA	BRIDGE DIODE ASS'Y	ASS'Y	1	EA
IC99	HVI74LCX32TTR	I.C , OR-GATE	ST	1	EA
	HVDKBU804F	DIODE , BRIDGE	KBU804F	1	EA
<i>Resistors</i>					
R101	CRD25FJ3R3T	RES , CARBON	3.3 OHM 1/4W J	1	EA
R108	CRD20TJ4R7T	RES , CARBON	4.7 OHM 1/5W J	1	EA
R109	CRD20TJ100T	RES , CARBON	10 OHM 1/5W J	1	EA
R110	CRD20TJ4R7T	RES , CARBON	4.7 OHM 1/5W J	1	EA
R112	CRD20TJ122T	RES , CARBON	1.2K OHM 1/5W J	1	EA
R113	CRD20TJ473T	RES , CARBON	47K OHM 1/5W J	1	EA
R120	CRD20TJ103T	RES , CARBON	10K OHM 1/5W J	1	EA
R912	CRD20TJ153T	RES , CARBON	15K OHM 1/5W J	1	EA
R913	CRD20TJ153T	RES , CARBON	15K OHM 1/5W J	1	EA
R917	CRD20TJ153T	RES , CARBON	15K OHM 1/5W J	1	EA
R918	CRD20TJ153T	RES , CARBON	15K OHM 1/5W J	1	EA
R919	CRD20TJ153T	RES , CARBON	15K OHM 1/5W J	1	EA
R920	CRD20TJ153T	RES , CARBON	15K OHM 1/5W J	1	EA
R921	CRD20TJ153T	RES , CARBON	15K OHM 1/5W J	1	EA
R922	CRD20TJ153T	RES , CARBON	15K OHM 1/5W J	1	EA
R923	CRD25TJ153T	RES , CARBON	15K OHM 1/4W J	1	EA
R924	CRD20TJ153T	RES , CARBON	15K OHM 1/5W J	1	EA
R925	CRD20TJ103T	RES , CARBON	10K OHM 1/5W J	1	EA
R926	CRD25TJ103T	RES , CARBON	10K OHM 1/4W J	1	EA
R927	CRD20TJ104T	RES , CARBON	100K OHM 1/5W J	1	EA
R928	CRD20TJ333T	RES , CARBON	33K OHM 1/5W J	1	EA
R104	KRQ1AJR47H	RES , FUSE	0.47 OHM 1W J	1	EA
R105	KRQ1AJR47H	RES , FUSE	0.47 OHM 1W J	1	EA
R106	CRQ1AJR33H	RES , FUSE	0.33 OHM 1W J	1	EA
R107	CRQ1AJR33H	RES , FUSE	0.33 OHM 1W J	1	EA
R114	KRQ1AJR47H	RES , FUSE	0.47 OHM 1W J	1	EA
R115	KRQ1AJR47H	RES , FUSE	0.47 OHM 1W J	1	EA
R116	CRQ1AJR33H	RES , FUSE	0.33 OHM 1W J	1	EA
R117	CRQ1AJR33H	RES , FUSE	0.33 OHM 1W J	1	EA
R118	CRQ1AJR33H	RES , FUSE	0.33 OHM 1W J	1	EA
R119	CRQ1AJR33H	RES , FUSE	0.33 OHM 1W J	1	EA
R949	CRQ1AJR33H	RES , FUSE	0.33 OHM 1W J	1	EA
R950	CRQ1AJR33H	RES , FUSE	0.33 OHM 1W J	1	EA

Ref. Designator	Part Number	Description		Qty	
POWER TRANS PCB (CUP11916-3,4)					
<i>Miscellaneous</i>					
BN22	CWB1C902280NN	WIRE ASS'Y	WIRE	1	EA
BN96	CWB1C909150BM	WIRE ASS'Y	WIRE	1	EA
BN99	CWB1B908270EN	WIRE ASS'Y	WIRE	1	EA
CN13	CJP05GA01ZY	CON WAFER YMW025-05R	WAFER	1	EA
CN19	CJP03GA90ZY	WAFER	WAFER	1	EA
CN20	CJP04GA90ZM	WAFER	WAFER	1	EA
CN81	CJP08GA01ZY	WAFER, STRAIGHT, 8PIN	WAFER	1	EA
	CMY1A219	HEAT SINK (BRIDGE DIODE)	HEAT SINK	1	EA
	CTB3+12JR	SCREW	SCREW	1	EA
	CMY1A219	HEAT SINK (BRIDGE DIODE)	HEAT SINK	1	EA
	CTB3+12JR	SCREW	SCREW	1	EA
ET04	CMD1A569	BRACKET , PCB	BRACKET	1	EA
ET05	CMD1A569	BRACKET , PCB	BRACKET	1	EA
VIDEO PCB (CUP11918)					
<i>Capacitors</i>					
C401	CCUS1H101JA	CAP , CHIP	100PF	1	EA
C402	CCUS1H101JA	CAP , CHIP	100PF	1	EA
C403	CCUS1H101JA	CAP , CHIP	100PF	1	EA
C461	CCUS1H223KC	CAP , CHIP	0.022UF	1	EA
C463	CCUS1H223KC	CAP , CHIP	0.022UF	1	EA
C465	CCUS1H470JA	CAP , CHIP	47PF	1	EA
C466	CCUS1H223KC	CAP , CHIP	0.022UF	1	EA
C468	CCUS1H223KC	CAP , CHIP	0.022UF	1	EA
C470	CCUS1H470JA	CAP , CHIP	47PF	1	EA
C471	CCUS1H223KC	CAP , CHIP	0.022UF	1	EA
C473	CCUS1H223KC	CAP , CHIP	0.022UF	1	EA
C475	CCUS1H470JA	CAP , CHIP	47PF	1	EA
C485	CCUS1H223KC	CAP , CHIP	0.022UF	1	EA
C487	CCUS1H223KC	CAP , CHIP	0.022UF	1	EA
C491	CCUS1H101JA	CAP , CHIP	100PF	1	EA
C492	CCUS1H101JA	CAP , CHIP	100PF	1	EA
C493	CCUS1H101JA	CAP , CHIP	100PF	1	EA
C601	CCUS1H220JA	CAP , CHIP	22PF	1	EA
C603	CCUS1H220JA	CAP , CHIP	22PF	1	EA
C605	CCUS1H220JA	CAP , CHIP	22PF	1	EA
C611	CCUS1H220JA	CAP , CHIP	22PF	1	EA
C613	CCUS1H220JA	CAP , CHIP	22PF	1	EA
C615	CCUS1H220JA	CAP , CHIP	22PF	1	EA
C621	CCUS1H220JA	CAP , CHIP	22PF	1	EA
C623	CCUS1H220JA	CAP , CHIP	22PF	1	EA
C625	CCUS1H220JA	CAP , CHIP	22PF	1	EA
C631	CCUS1H220JA	CAP , CHIP	22PF	1	EA
C633	CCUS1H220JA	CAP , CHIP	22PF	1	EA
C635	CCUS1H220JA	CAP , CHIP	22PF	1	EA
C672	CCUS1H104KC	CAP , CHIP	0.1UF	1	EA
C677	CCUS1H473KC	CAP , CHIP	0.047UF	1	EA
C404	CCEA0JH102T	CAP , ELECT	1000UF 6.3V	1	EA
C405	CCEA1HH100T	CAP , ELECT	10UF 50V	1	EA
C406	CCEA0JH102T	CAP , ELECT	1000UF 6.3V	1	EA
C411	CCEA1HH100T	CAP , ELECT	10UF 50V	1	EA
C412	CCEA1HH100T	CAP , ELECT	10UF 50V	1	EA
C413	CCEA1HH100T	CAP , ELECT	10UF 50V	1	EA
C421	CCEA1HH100T	CAP , ELECT	10UF 50V	1	EA
C422	CCEA1HH100T	CAP , ELECT	10UF 50V	1	EA
C423	CCEA1HH100T	CAP , ELECT	10UF 50V	1	EA
C431	CCEA1HH100T	CAP , ELECT	10UF 50V	1	EA

Ref. Designator	Part Number	Description		Qty	
VIDEO PCB (CUP11918)					
C432	CCEA1HH100T	CAP , ELECT	10UF 50V	1	EA
C433	CCEA1HH100T	CAP , ELECT	10UF 50V	1	EA
C451	CCEA1HH100T	CAP , ELECT	10UF 50V	1	EA
C452	CCEA1HH100T	CAP , ELECT	10UF 50V	1	EA
C453	CCEA1HH100T	CAP , ELECT	10UF 50V	1	EA
C462	CCEA1CH101T	CAP , ELECT	100UF 16V	1	EA
C464	CCEA1CH101T	CAP , ELECT	100UF 16V	1	EA
C467	CCEA1CH101T	CAP , ELECT	100UF 16V	1	EA
C469	CCEA1CH101T	CAP , ELECT	100UF 16V	1	EA
C472	CCEA1CH101T	CAP , ELECT	100UF 16V	1	EA
C474	CCEA1CH101T	CAP , ELECT	100UF 16V	1	EA
C486	CCEA1CH101T	CAP , ELECT	100UF 16V	1	EA
C488	CCEA1CH101T	CAP , ELECT	100UF 16V	1	EA
C602	CCEA0JH102T	CAP , ELECT	1000UF 6.3V	1	EA
C604	CCEA0JH102T	CAP , ELECT	1000UF 6.3V	1	EA
C606	CCEA0JH102T	CAP , ELECT	1000UF 6.3V	1	EA
C612	CCEA1HH100T	CAP , ELECT	10UF 50V	1	EA
C614	CCEA1HH100T	CAP , ELECT	10UF 50V	1	EA
C616	CCEA1HH100T	CAP , ELECT	10UF 50V	1	EA
C622	CCEA1HH100T	CAP , ELECT	10UF 50V	1	EA
C624	CCEA1HH100T	CAP , ELECT	10UF 50V	1	EA
C626	CCEA1HH100T	CAP , ELECT	10UF 50V	1	EA
C632	CCEA1HH100T	CAP , ELECT	10UF 50V	1	EA
C634	CCEA1HH100T	CAP , ELECT	10UF 50V	1	EA
C636	CCEA1HH100T	CAP , ELECT	10UF 50V	1	EA
C641	CCEA1HH100T	CAP , ELECT	10UF 50V	1	EA
C643	CCEA1HH100T	CAP , ELECT	10UF 50V	1	EA
C645	CCEA1HH100T	CAP , ELECT	10UF 50V	1	EA
C671	CCEA1CH101T	CAP , ELECT	100UF 16V	1	EA
C673	CCEA1HH100T	CAP , ELECT	10UF 50V	1	EA
C676	CCEA1CH101T	CAP , ELECT	100UF 16V	1	EA
C678	CCEA1CH101T	CAP , ELECT	100UF 16V	1	EA
<i>Semiconductors</i>					
IC62	HVIMC7809C	I.C , REGULATOR (+9V)	FAIRCHILD	1	EA
IC41	CVINJM2595MTE1	I.C , VIDEO S/W	JRC	1	EA
IC42	CVINJM2595MTE1	I.C , VIDEO S/W	JRC	1	EA
IC43	CVINJM2595MTE1	I.C , VIDEO S/W	JRC	1	EA
IC48	HVIHCF4053M013T	I.C, ANALOG MULTIPLEXER	ST	1	EA
IC61	CVINJW1321FP1	I.C , VIDEO S/W	JRC	1	EA
<i>Resistors</i>					
R401	CRJ10DJ750T	RES , CHIP	75 OHM	1	EA
R402	CRJ10DJ750T	RES , CHIP	75 OHM	1	EA
R403	CRJ10DJ750T	RES , CHIP	75 OHM	1	EA
R411	CRJ10DJ750T	RES , CHIP	75 OHM	1	EA
R412	CRJ10DJ750T	RES , CHIP	75 OHM	1	EA
R413	CRJ10DJ750T	RES , CHIP	75 OHM	1	EA
R421	CRJ10DJ750T	RES , CHIP	75 OHM	1	EA
R422	CRJ10DJ750T	RES , CHIP	75 OHM	1	EA
R423	CRJ10DJ750T	RES , CHIP	75 OHM	1	EA
R431	CRJ10DJ750T	RES , CHIP	75 OHM	1	EA
R432	CRJ10DJ750T	RES , CHIP	75 OHM	1	EA
R433	CRJ10DJ750T	RES , CHIP	75 OHM	1	EA
R451	CRJ10DJ750T	RES , CHIP	75 OHM	1	EA
R452	CRJ10DJ750T	RES , CHIP	75 OHM	1	EA
R453	CRJ10DJ750T	RES , CHIP	75 OHM	1	EA
R461	CRJ10DJ102T	RES , CHIP	1K OHM	1	EA
R462	CRJ10DJ820T	RES , CHIP	82 OHM	1	EA

Ref. Designator	Part Number	Description		Qty	
VIDEO PCB (CUP11918)					
R463	CRJ10DJ910T	RES , CHIP	91 OHM	1	EA
R466	CRJ10DJ102T	RES , CHIP	1K OHM	1	EA
R467	CRJ10DJ750T	RES , CHIP	75 OHM	1	EA
R468	CRJ10DJ910T	RES , CHIP	91 OHM	1	EA
R471	CRJ10DJ102T	RES , CHIP	1K OHM	1	EA
R472	CRJ10DJ820T	RES , CHIP	82 OHM	1	EA
R473	CRJ10DJ910T	RES , CHIP	91 OHM	1	EA
R485	CRJ10DJ100T	RES , CHIP	10 OHM	1	EA
R487	CRJ10DJ100T	RES , CHIP	10 OHM	1	EA
R491	CRJ10DJ750T	RES , CHIP	75 OHM	1	EA
R492	CRJ10DJ750T	RES , CHIP	75 OHM	1	EA
R493	CRJ10DJ750T	RES , CHIP	75 OHM	1	EA
R494	CRJ10DJ102T	RES , CHIP	1K OHM	1	EA
R601	CRJ10DJ820T	RES , CHIP	82 OHM	1	EA
R603	CRJ10DJ680T	RES , CHIP	68 OHM	1	EA
R604	CRJ10DJ0R0T	RES , CHIP	0 OHM	1	EA
R605	CRJ10DJ680T	RES , CHIP	68 OHM	1	EA
R611	CRJ10DJ750T	RES , CHIP	75 OHM	1	EA
R612	CRJ10DJ750T	RES , CHIP	75 OHM	1	EA
R613	CRJ10DJ750T	RES , CHIP	75 OHM	1	EA
R614	CRJ10DJ0R0T	RES , CHIP	0 OHM	1	EA
R615	CRJ10DJ0R0T	RES , CHIP	0 OHM	1	EA
R616	CRJ10DJ0R0T	RES , CHIP	0 OHM	1	EA
R621	CRJ10DJ750T	RES , CHIP	75 OHM	1	EA
R622	CRJ10DJ750T	RES , CHIP	75 OHM	1	EA
R623	CRJ10DJ750T	RES , CHIP	75 OHM	1	EA
R624	CRJ10DJ0R0T	RES , CHIP	0 OHM	1	EA
R625	CRJ10DJ0R0T	RES , CHIP	0 OHM	1	EA
R626	CRJ10DJ0R0T	RES , CHIP	0 OHM	1	EA
R631	CRJ10DJ750T	RES , CHIP	75 OHM	1	EA
R633	CRJ10DJ750T	RES , CHIP	75 OHM	1	EA
R635	CRJ10DJ750T	RES , CHIP	75 OHM	1	EA
<i>Miscellaneous</i>					
BN14	CJP17GA117ZY	WAFER	WAFER	1	EA
BN15	CJP15GB113ZY	WAFER	WAFER	1	EA
BN81	CJP44TT153ZY	PIN , HEADER (2.00MM, 44PIN)	PIN HEADER	1	EA
CN41	CJP06GA19ZY	WAFER, STRAIGHT, 6PIN	WAFER	1	EA
CN42	CJP11GB113ZY	WAFER , CARDCABLE	WAFER	1	EA
CN43	CJP03GB03ZY	WAFER	WAFER	1	EA
JK40	CJJ9R001Z	JACK , (S-VIDEO + CVBS)	JACK	1	EA
JK41	CJJ9R001Z	JACK , (S-VIDEO + CVBS)	JACK	1	EA
JK62	CJJ4R045Z	JACK , BOARD	JACK	1	EA
JK69	CJJ4R045Z	JACK , BOARD	JACK	1	EA
REMOTE IN/OUT PCB (CUP11849-12)					
C970	CCKT1H561KB	CAP , CERAMIC	560PF 50V	1	EA
C971	CCFT1H104ZF	CAP , SEMICONDUCTOR	0.1UF 50V ZF	1	EA
R970	CRD20TJ103T	RES , CARBON	10K OHM 1/5W J	1	EA
R971	CRD20TJ103T	RES , CARBON	10K OHM 1/5W J	1	EA
R972	CRD20TJ473T	RES , CARBON	47K OHM 1/5W J	1	EA
R973	CRD20TJ473T	RES , CARBON	47K OHM 1/5W J	1	EA
R974	CRD20TJ271T	RES , CARBON	270 OHM 1/5W J	1	EA
R975	CRD20TJ271T	RES , CARBON	270 OHM 1/5W J	1	EA
R976	CRD20TJ470T	RES , CARBON	47 OHM 1/5W J	1	EA
R977	CRD20TJ103T	RES , CARBON	10K OHM 1/5W J	1	EA
D921	CVD1SS133MT	DIODE	1SS133	1	EA
Q995	HVTKRA107MT	TRANSISTOR PNP	KRA107M	1	EA
Q996	HVTKRC107MT	TRANSISTOR NPN	KRC107M	1	EA

Ref. Designator	Part Number	Description		Qty	
REMOTE IN/OUT PCB (CUP11849-12)					
Q997	HVTKRC107MT	TRANSISTOR PNP	KRC107M	1	EA
IC97	BVIKP1010B	IC, PHOTO COUPLER	COSMO	1	EA
IC98	BVIKP1010B	IC, PHOTO COUPLER	COSMO	1	EA
JK94	CJJ2D008Z	JACK , STEREO	JACK	1	EA
JK95	CJJ2D008Z	JACK , STEREO	JACK	1	EA
JK96	CJJ2D008Z	JACK , STEREO	JACK	1	EA
JK99	CJJ2D008Z	JACK , STEREO	JACK	1	EA
CN88	CJP06GA19ZY	WAFER, STRAIGHT, 6PIN	WAFER	1	EA
IPOD PCB (CUP11913-2)					
<i>Capacitors</i>					
C400	CCUS1H104KC	CAP , CHIP	0.1UF	1	EA
C401	CCUS1H104KC	CAP , CHIP	0.1UF	1	EA
C405	CCUC1C225ZF	CAP , CHIP	2.2UF	1	EA
C406	CCUC1C225ZF	CAP , CHIP	2.2UF	1	EA
C410	CCUS1A105KC	CAP , CHIP	1UF	1	EA
C411	CCUS1A105KC	CAP , CHIP	1UF	1	EA
C416	CCUS1H473KC	CAP , CHIP	0.047UF	1	EA
C417	CCEA1CH471T	CAP , ELECT	470UF 16V	1	EA
C420	CCUS1A105KC	CAP , CHIP	1UF	1	EA
C421	CCUS1A105KC	CAP , CHIP	1UF	1	EA
C422	CCUS1A105KC	CAP , CHIP	1UF	1	EA
C423	CCUS1H220JA	CAP , CHIP	22PF	1	EA
C424	CCUS1H220JA	CAP , CHIP	22PF	1	EA
C425	CCUS1H223KC	CAP , CHIP	0.022UF	1	EA
C426	CCUS1H223KC	CAP , CHIP	0.022UF	1	EA
C427	CCUS1H223KC	CAP , CHIP	0.022UF	1	EA
C430	CCEA1AH331T	CAP , ELECT	330UF 10V	1	EA
C431	CCEA1CH221T	CAP , ELECT	220UF 16V	1	EA
C432	HCEC1CRV2220T	CAP , ELEC (SMD)	22UF/16V	1	EA
C433	CCEA1CH101T	CAP , ELECT	100UF 16V	1	EA
C435	CCUS1H070DA	CAP , CHIP	7PF	1	EA
C436	CCUS1H120JA	CAP , CHIP	12PF	1	EA
C440	CCUS1H223KC	CAP , CHIP	0.022UF	1	EA
C445	HCEC1CRV2220T	CAP , ELEC (SMD)	22UF/16V	1	EA
C459	CCUS1H151JA	CAP , CHIP	150PF	1	EA
<i>Semiconductors</i>					
D400	CVD1SS355T	CHIP , DIODE	1SS355T	1	EA
D401	CVD1SS355T	CHIP , DIODE	1SS355T	1	EA
D402	CVD1N4003SRT	RECT , DIODE	1N4003	1	EA
IC41	HVINJM2068MDTE1	I.C , DUAL OP AMP	JRC	1	EA
IC42	HVINJM2068MDTE1	I.C , DUAL OP AMP	JRC	1	EA
IC43	HVINJM2137MTE1	I.C , DUAL OP AMP	JRC	1	EA
Q402	HVTKRC102S	TRANSISTOR , CHIP NPN	KRC102S	1	EA
<i>Resistors</i>					
R400	CRJ10DJ4R7T	RES , CHIP	4.7 OHM	1	EA
R401	CRJ10DJ4R7T	RES , CHIP	4.7 OHM	1	EA
R402	CRJ10DF5493T	RES , CHIP	549K OHM	1	EA
R403	CRJ10DJ0R0T	RES , CHIP	0 OHM	1	EA
R404	CRJ10DJ103T	RES , CHIP	10K OHM	1	EA
R405	CRJ10DJ103T	RES , CHIP	10K OHM	1	EA
R406	CRJ10DJ474T	RES , CHIP	470K OHM	1	EA
R407	CRJ10DJ474T	RES , CHIP	470K OHM	1	EA
R421	CRJ10DJ222T	RES , CHIP	2.2K OHM	1	EA
R422	CRJ10DJ474T	RES , CHIP	470K OHM	1	EA

Ref. Designator	Part Number	Description		Qty	
IPOD PCB (CUP11913-2)					
R430	CRJ10DJ473T	RES , CHIP	47K OHM	1	EA
R431	CRJ10DJ473T	RES , CHIP	47K OHM	1	EA
R432	CRJ18AJ221T	RES , CHIP	220 OHM	1	EA
R433	CRJ18AJ221T	RES , CHIP	220 OHM	1	EA
R434	CRJ10DJ103T	RES , CHIP	10K OHM	1	EA
R435	CRJ10DJ103T	RES , CHIP	10K OHM	1	EA
R436	CRJ10DJ222T	RES , CHIP	2.2K OHM	1	EA
R437	CRJ10DJ222T	RES , CHIP	2.2K OHM	1	EA
R438	CRJ10DJ222T	RES , CHIP	2.2K OHM	1	EA
R439	CRJ10DJ222T	RES , CHIP	2.2K OHM	1	EA
R440	CRJ10DJ220T	RES , CHIP	22 OHM	1	EA
R441	CRJ10DJ472T	RES , CHIP	4.7K OHM	1	EA
R442	CRJ10DJ472T	RES , CHIP	4.7K OHM	1	EA
R443	CRJ10DJ202T	RES , CHIP	2K OHM	1	EA
R445	CRJ10DJ202T	RES , CHIP	2K OHM	1	EA
R446	CRJ10DJ431T	RES , CHIP	430 OHM	1	EA
R447	CRJ10DJ821T	RES , CHIP	820 OHM	1	EA
R448	CRJ10DJ184T	RES , CHIP	180K OHM	1	EA
R449	CRJ10DJ0R0T	RES , CHIP	0 OHM	1	EA
R453	CRJ10DJ220T	RES , CHIP	22 OHM	1	EA
<i>Miscellaneous</i>					
CN47	CJP07GA117ZY	TEMP ITEM	WAFER	1	EA
JK40	HJJ9L003Z	JACK , IPOD	IPOD JACK	1	EA
A-BUS PCB (CUP11913-3)					
<i>Capacitors</i>					
C412	CCUS1H223KC	CAP , CHIP	0.022UF	1	EA
C413	CCUS1H223KC	CAP , CHIP	0.022UF	1	EA
C414	CCEA1HH100T	CAP , ELECT	10UF 50V	1	EA
C415	CCEA1HH100T	CAP , ELECT	10UF 50V	1	EA
C428	CCUS1H151JA	CAP , CHIP	150PF	1	EA
C441	CCEA1CH101T	CAP , ELECT	100UF 16V	1	EA
C442	CCUS1H151JA	CAP , CHIP	150PF	1	EA
C443	CCEA1HH100T	CAP , ELECT	10UF 50V	1	EA
C444	CCEA1HH100T	CAP , ELECT	10UF 50V	1	EA
C446	CCEA1CH101T	CAP , ELECT	100UF 16V	1	EA
C449	CCEA1CH101T	CAP , ELECT	100UF 16V	1	EA
C450	CCEA1VH471E	CAP , ELECT	470UF/ 35V	1	EA
C452	CCEA1HH100T	CAP , ELECT	10UF 50V	1	EA
C453	CCEA1HH100T	CAP , ELECT	10UF 50V	1	EA
C454	CCEA1CH101T	CAP , ELECT	100UF 16V	1	EA
C467	CCUS1A105KC	CAP , CHIP	1UF	1	EA
C468	CCUS1A105KC	CAP , CHIP	1UF	1	EA
C469	CCUS1A105KC	CAP , CHIP	1UF	1	EA
C470	CCUS1A105KC	CAP , CHIP	1UF	1	EA
C475	CCUS1H104KC	CAP , CHIP	0.1UF	1	EA
C476	CCUS1H101JA	CAP , CHIP	100PF	1	EA
C477	CCUS1H101JA	CAP , CHIP	100PF	1	EA
C478	CCUS1A105KC	CAP , CHIP	1UF	1	EA
C479	CCUS1A105KC	CAP , CHIP	1UF	1	EA
<i>Semiconductors</i>					
D443	CVDZJ6.8BT	DIODE , ZENER	ZJ6.8B 1/2W	1	EA
D444	CVDZJ6.8BT	DIODE , ZENER	ZJ6.8B 1/2W	1	EA
D445	CVDZJ6.8BT	DIODE , ZENER	ZJ6.8B 1/2W	1	EA
D446	CVDZJ6.8BT	DIODE , ZENER	ZJ6.8B 1/2W	1	EA

Ref. Designator	Part Number	Description		Qty	
A-BUS PCB (CUP11913-3)					
D447	HVDMTZJ12BT	DIODE , ZENER	MTZJ12B 1/2W	1	EA
D475	HVD1SS355T	DIODE , CHIP	1SS355T	1	EA
IC44	HVINJW1159M	I.C , VOLUME (2-CH)	JRC	1	EA
IC45	HVINJM2068MDTE1	I.C , DUAL OP AMP	JRC	1	EA
Q451	HVTKTC2874BT	TRANSISTOR , MUTE NPN	KTC2874B	1	EA
Q452	HVTKTC2874BT	TRANSISTOR , MUTE NPN	KTC2874B	1	EA
Q453	HVTKTC2874BT	TRANSISTOR , MUTE NPN	KTC2874B	1	EA
Q454	HVTKTC2874BT	TRANSISTOR , MUTE NPN	KTC2874B	1	EA
<i>Resistors</i>					
R452	CRJ10DJ184T	RES , CHIP	180K OHM	1	EA
R454	CRJ10DJ562T	RES , CHIP	5.6K OHM	1	EA
R455	CRJ10DJ122T	RES , CHIP	1.2K OHM	1	EA
R456	CRJ10DJ562T	RES , CHIP	5.6K OHM	1	EA
R457	CRJ10DJ821T	RES , CHIP	820 OHM	1	EA
R458	CRJ10DJ821T	RES , CHIP	820 OHM	1	EA
R459	CRD20TJ472T	RES , CARBON	4.7K OHM 1/5W J	1	EA
R460	CRJ10DJ184T	RES , CHIP	180K OHM	1	EA
R461	CRJ10DJ104T	RES , CHIP	100K OHM	1	EA
R462	CRJ10DJ104T	RES , CHIP	100K OHM	1	EA
R463	CRJ10DJ821T	RES , CHIP	820 OHM	1	EA
R464	CRJ10DJ821T	RES , CHIP	820 OHM	1	EA
R465	CRJ10DJ472T	RES , CHIP	4.7K OHM	1	EA
R466	CRJ10DJ472T	RES , CHIP	4.7K OHM	1	EA
R467	CRJ10DJ472T	RES , CHIP	4.7K OHM	1	EA
R468	CRJ10DJ472T	RES , CHIP	4.7K OHM	1	EA
R469	CRJ10DJ184T	RES , CHIP	180K OHM	1	EA
R470	CRJ10DJ184T	RES , CHIP	180K OHM	1	EA
R471	CRJ10DJ101T	RES , CHIP	100 OHM	1	EA
R472	CRJ10DJ101T	RES , CHIP	100 OHM	1	EA
R473	CRJ10DJ184T	RES , CHIP	180K OHM	1	EA
R474	CRJ10DJ122T	RES , CHIP	1.2K OHM	1	EA
R475	CRJ10DJ4R7T	RES , CHIP	4.7 OHM	1	EA
R476	CRJ10DJ101T	RES , CHIP	100 OHM	1	EA
R477	CRJ10DJ101T	RES , CHIP	100 OHM	1	EA
R478	CRJ10DJ562T	RES , CHIP	5.6K OHM	1	EA
R479	CRJ10DJ562T	RES , CHIP	5.6K OHM	1	EA
R480	CRJ10DJ102T	RES , CHIP	1K OHM	1	EA
R489	CRJ10DJ332T	RES , CHIP	3.3K OHM	1	EA
R490	CRJ10DJ332T	RES , CHIP	3.3K OHM	1	EA
R499	CRJ10DJ102T	RES , CHIP	1K OHM	1	EA
<i>Miscellaneous</i>					
BN16	CJP12GA115ZY	WAFER , CARD CABLE	WAFER	1	EA
BN90	CWB1C902370EN	WIRE ASS'Y	WIRE	1	EA
JK16	CJJ4N076Z	JACK , IN/OUT	JACK	1	EA
JK17	CJJ9L004Z	JACK , RJ-45	JACK	1	EA
HUDSON (HDMI) PCB (CUP11915)					
<i>Capacitors</i>					
C701	CCUS1H104KC	CAP , CHIP	0.1UF	1	EA
C702	CCUS1H104KC	CAP , CHIP	0.1UF	1	EA
C803	CCUS1H104KC	CAP , CHIP	0.1UF	1	EA
C804	CCUS1H104KC	CAP , CHIP	0.1UF	1	EA
C805	CCUS1H101JA	CAP , CHIP	100PF	1	EA
C806	CCUS1H470JA	CAP , CHIP	47UF	1	EA
C807	CCUS1H470JA	CAP , CHIP	47UF	1	EA

Ref. Designator	Part Number	Description		Qty	
HUDSON (HDMI) PCB (CUP11915)					
C808	CCUS1H104KC	CAP , CHIP	0.1UF	1	EA
C809	CCUS1H104KC	CAP , CHIP	0.1UF	1	EA
C810	CCUS1H104KC	CAP , CHIP	0.1UF	1	EA
C811	CCUS1H104KC	CAP , CHIP	0.1UF	1	EA
C812	CCUS1H104KC	CAP , CHIP	0.1UF	1	EA
C813	CCUS1H104KC	CAP , CHIP	0.1UF	1	EA
C814	CCUS1H104KC	CAP , CHIP	0.1UF	1	EA
C815	CCUS1H104KC	CAP , CHIP	0.1UF	1	EA
C816	CCUS1H104KC	CAP , CHIP	0.1UF	1	EA
C817	CCUS1H104KC	CAP , CHIP	0.1UF	1	EA
C818	CCUS1H104KC	CAP , CHIP	0.1UF	1	EA
C819	CCUS1H104KC	CAP , CHIP	0.1UF	1	EA
C820	CCUS1H104KC	CAP , CHIP	0.1UF	1	EA
C821	CCUS1H104KC	CAP , CHIP	0.1UF	1	EA
C822	CCUS1H104KC	CAP , CHIP	0.1UF	1	EA
C823	CCUS1H104KC	CAP , CHIP	0.1UF	1	EA
C824	CCUS1H104KC	CAP , CHIP	0.1UF	1	EA
C825	CCUS1H104KC	CAP , CHIP	0.1UF	1	EA
C826	CCUS1H104KC	CAP , CHIP	0.1UF	1	EA
C827	CCUS1H104KC	CAP , CHIP	0.1UF	1	EA
C828	CCUS1H104KC	CAP , CHIP	0.1UF	1	EA
C829	CCUS1H104KC	CAP , CHIP	0.1UF	1	EA
C830	CCUS1H104KC	CAP , CHIP	0.1UF	1	EA
C831	CCUS1H104KC	CAP , CHIP	0.1UF	1	EA
C832	CCUS1H104KC	CAP , CHIP	0.1UF	1	EA
C833	CCUS1H104KC	CAP , CHIP	0.1UF	1	EA
C834	CCUS1H104KC	CAP , CHIP	0.1UF	1	EA
C835	CCUS1H104KC	CAP , CHIP	0.1UF	1	EA
C836	CCUS1H104KC	CAP , CHIP	0.1UF	1	EA
C837	CCUS1H104KC	CAP , CHIP	0.1UF	1	EA
C838	CCUS1H104KC	CAP , CHIP	0.1UF	1	EA
C839	CCUS1H104KC	CAP , CHIP	0.1UF	1	EA
C840	CCUS1H104KC	CAP , CHIP	0.1UF	1	EA
C841	CCUS1H104KC	CAP , CHIP	0.1UF	1	EA
C842	CCUS1H104KC	CAP , CHIP	0.1UF	1	EA
C843	CCUS1H104KC	CAP , CHIP	0.1UF	1	EA
C844	CCUS1H104KC	CAP , CHIP	0.1UF	1	EA
C845	CCUS1H104KC	CAP , CHIP	0.1UF	1	EA
C846	CCUS1H104KC	CAP , CHIP	0.1UF	1	EA
C847	CCUS1H392KC	CAP , CHIP	3900PF	1	EA
C848	CCUS1H821JA	CAP , CHIP	820PF	1	EA
C849	CCUS1H104KC	CAP , CHIP	0.1UF	1	EA
C850	CCUS1H104KC	CAP , CHIP	0.1UF	1	EA
C851	CCUS1H104KC	CAP , CHIP	0.1UF	1	EA
C852	CCUS1H104KC	CAP , CHIP	0.1UF	1	EA
C853	CCUS1H104KC	CAP , CHIP	0.1UF	1	EA
C854	CCUS1H104KC	CAP , CHIP	0.1UF	1	EA
C855	CCUS1H104KC	CAP , CHIP	0.1UF	1	EA
C856	CCUS1A105KC	CAP , CHIP	1UF	1	EA
C857	CCUS1A105KC	CAP , CHIP	1UF	1	EA
C858	HCEC1CRV2220T	CAP , ELEC (SMD)	22UF/16V	1	EA
C859	CCUS1H104KC	CAP , CHIP	0.1UF	1	EA
C860	CCUS1H104KC	CAP , CHIP	0.1UF	1	EA
C861	CCUS1H104KC	CAP , CHIP	0.1UF	1	EA
C862	CCUS1H104KC	CAP , CHIP	0.1UF	1	EA
C863	CCUS1H104KC	CAP , CHIP	0.1UF	1	EA
C864	CCUS1H104KC	CAP , CHIP	0.1UF	1	EA
C865	CCUS1H104KC	CAP , CHIP	0.1UF	1	EA
C866	HCEC0JRV2220T	CAP , CHIP ELECT	22UF/6.3V	1	EA
C867	HCEC0JRV2220T	CAP , CHIP ELECT	22UF/6.3V	1	EA
C868	HCEC0JRV2220T	CAP , CHIP ELECT	22UF/6.3V	1	EA

Ref. Designator	Part Number	Description		Qty	
HUDSON (HDMI) PCB (CUP11915)					
C869	HCEC0JRV2220T	CAP , CHIP ELECT	22UF/6.3V	1	EA
C870	HCEC0JRV2220T	CAP , CHIP ELECT	22UF/6.3V	1	EA
C871	HCEC0JRV2220T	CAP , CHIP ELECT	22UF/6.3V	1	EA
C872	HCEC0JRV2220T	CAP , CHIP ELECT	22UF/6.3V	1	EA
C873	HCEC0JRV2220T	CAP , CHIP ELECT	22UF/6.3V	1	EA
C874	HCEC0JRV2220T	CAP , CHIP ELECT	22UF/6.3V	1	EA
C875	HCEC0JRV2220T	CAP , CHIP ELECT	22UF/6.3V	1	EA
C876	HCEC0JRV2220T	CAP , CHIP ELECT	22UF/6.3V	1	EA
C877	HCEC0JRV2220T	CAP , CHIP ELECT	22UF/6.3V	1	EA
C878	HCEC0JRV2220T	CAP , CHIP ELECT	22UF/6.3V	1	EA
C879	HCEC0JRV2220T	CAP , CHIP ELECT	22UF/6.3V	1	EA
C880	HCEC0JRV2220T	CAP , CHIP ELECT	22UF/6.3V	1	EA
C881	HCEC0JRV2220T	CAP , CHIP ELECT	22UF/6.3V	1	EA
C882	HCEC0JRV2220T	CAP , CHIP ELECT	22UF/6.3V	1	EA
C883	HCEC0JRV2220T	CAP , CHIP ELECT	22UF/6.3V	1	EA
C884	HCEC0JRV2220T	CAP , CHIP ELECT	22UF/6.3V	1	EA
C885	CCUS1H104KC	CAP , CHIP	0.1UF	1	EA
C886	HCEC0JRV2220T	CAP , CHIP ELECT	22UF/6.3V	1	EA
C887	CCUS1H104KC	CAP , CHIP	0.1UF	1	EA
C888	CCUS1H104KC	CAP , CHIP	0.1UF	1	EA
C889	CCUS1H104KC	CAP , CHIP	0.1UF	1	EA
C891	HCEC0JRV2220T	CAP , CHIP ELECT	22UF/6.3V	1	EA
C892	HCEC0JRV2220T	CAP , CHIP ELECT	22UF/6.3V	1	EA
C893	HCEC0JRV2220T	CAP , CHIP ELECT	22UF/6.3V	1	EA
C894	HCEC0JRV2220T	CAP , CHIP ELECT	22UF/6.3V	1	EA
C895	HCEC0JRV2101T	CAP , CHIP ELECT	100UF/6.3V	1	EA
C896	HCEC0JRV2220T	CAP , CHIP ELECT	22UF/6.3V	1	EA
C897	HCEC0JRV2220T	CAP , CHIP ELECT	22UF/6.3V	1	EA
C898	CCUS1H104KC	CAP , CHIP	0.1UF	1	EA
C899	CCUS1H104KC	CAP , CHIP	0.1UF	1	EA
C900	CCUS1H104KC	CAP , CHIP	0.1UF	1	EA
C901	CCUS1H104KC	CAP , CHIP	0.1UF	1	EA
C902	CCUS1H104KC	CAP , CHIP	0.1UF	1	EA
C903	CCUS1H104KC	CAP , CHIP	0.1UF	1	EA
C904	CCUS1H104KC	CAP , CHIP	0.1UF	1	EA
C905	CCUS1H104KC	CAP , CHIP	0.1UF	1	EA
C906	CCUS1H104KC	CAP , CHIP	0.1UF	1	EA
C907	CCUS1H104KC	CAP , CHIP	0.1UF	1	EA
C908	CCUS1H104KC	CAP , CHIP	0.1UF	1	EA
C909	CCUS1H104KC	CAP , CHIP	0.1UF	1	EA
C910	CCUS1H103KC	CAP , CHIP	0.01UF	1	EA
C911	CCUS1H103KC	CAP , CHIP	0.01UF	1	EA
C912	CCUS1H104KC	CAP , CHIP	0.1UF	1	EA
C913	CCUS1H104KC	CAP , CHIP	0.1UF	1	EA
C914	CCUS1H104KC	CAP , CHIP	0.1UF	1	EA
C915	CCUS1H104KC	CAP , CHIP	0.1UF	1	EA
C916	CCUS1H104KC	CAP , CHIP	0.1UF	1	EA
C917	CCUS1H104KC	CAP , CHIP	0.1UF	1	EA
C918	CCUS1H104KC	CAP , CHIP	0.1UF	1	EA
C919	CCUS1H104KC	CAP , CHIP	0.1UF	1	EA
C920	CCUS1H104KC	CAP , CHIP	0.1UF	1	EA
C921	CCUS1H104KC	CAP , CHIP	0.1UF	1	EA
C922	CCUS1H180JA	CAP , CHIP	18PF	1	EA
C923	CCUS1H180JA	CAP , CHIP	18PF	1	EA
C924	CCUS1H104KC	CAP , CHIP	0.1UF	1	EA
C925	CCUS1H104KC	CAP , CHIP	0.1UF	1	EA
C926	CCUS1H104KC	CAP , CHIP	0.1UF	1	EA
C927	CCUS1H104KC	CAP , CHIP	0.1UF	1	EA
C928	CCUS1H104KC	CAP , CHIP	0.1UF	1	EA
C929	CCUS1H104KC	CAP , CHIP	0.1UF	1	EA
C930	CCUS1H104KC	CAP , CHIP	0.1UF	1	EA

Ref. Designator	Part Number	Description		Qty	
HUDSON (HDMI) PCB (CUP11915)					
C931	CCUS1H104KC	CAP , CHIP	0.1UF	1	EA
C932	CCUS1H104KC	CAP , CHIP	0.1UF	1	EA
C933	CCUS1H104KC	CAP , CHIP	0.1UF	1	EA
C934	CCUS1H104KC	CAP , CHIP	0.1UF	1	EA
C935	CCUS1H104KC	CAP , CHIP	0.1UF	1	EA
C936	CCUS1H103KC	CAP , CHIP	0.01UF	1	EA
C937	CCUS1H104KC	CAP , CHIP	0.1UF	1	EA
C938	CCUS1H104KC	CAP , CHIP	0.1UF	1	EA
C939	CCUS1H104KC	CAP , CHIP	0.1UF	1	EA
C941	CCUS1H104KC	CAP , CHIP	0.1UF	1	EA
C942	CCUS1H104KC	CAP , CHIP	0.1UF	1	EA
C944	CCUS1H104KC	CAP , CHIP	0.1UF	1	EA
C945	CCUS1H104KC	CAP , CHIP	0.1UF	1	EA
C946	CCUS1H104KC	CAP , CHIP	0.1UF	1	EA
C947	CCUS1H104KC	CAP , CHIP	0.1UF	1	EA
C948	CCUS1H104KC	CAP , CHIP	0.1UF	1	EA
C949	CCUS1H104KC	CAP , CHIP	0.1UF	1	EA
C950	CCUS1H104KC	CAP , CHIP	0.1UF	1	EA
C951	CCUS1H104KC	CAP , CHIP	0.1UF	1	EA
C952	CCUS1H104KC	CAP , CHIP	0.1UF	1	EA
C953	CCUS1H104KC	CAP , CHIP	0.1UF	1	EA
C954	CCUS1H104KC	CAP , CHIP	0.1UF	1	EA
C955	CCUS1H104KC	CAP , CHIP	0.1UF	1	EA
C956	HCEC0JRV2220T	CAP , CHIP ELECT	22UF/6.3V	1	EA
C957	HCEC0JRV2220T	CAP , CHIP ELECT	22UF/6.3V	1	EA
C958	HCEC0JRV2220T	CAP , CHIP ELECT	22UF/6.3V	1	EA
C959	HCEC0JRV2220T	CAP , CHIP ELECT	22UF/6.3V	1	EA
C960	HCEC0JRV2220T	CAP , CHIP ELECT	22UF/6.3V	1	EA
C961	HCEC0JRV2220T	CAP , CHIP ELECT	22UF/6.3V	1	EA
C962	HCEC1CRV2100T	CAP , ELEC (SMD)	10UF / 16V	1	EA
C963	CCUS1H104KC	CAP , CHIP	0.1UF	1	EA
C964	CCUS1H104KC	CAP , CHIP	0.1UF	1	EA
C965	CCUS1A105KC	CAP , CHIP	1UF	1	EA
C966	HCEC0JRV2220T	CAP , CHIP ELECT	22UF/6.3V	1	EA
C967	HCEC0JRV2101T	CAP , CHIP ELECT	100UF/6.3V	1	EA
C975	HCEC0JRV2220T	CAP , CHIP ELECT	22UF/6.3V	1	EA
C976	HCEC0JRV2101T	CAP , CHIP ELECT	100UF/6.3V	1	EA
C978	HCEC0JRV2101T	CAP , CHIP ELECT	100UF/6.3V	1	EA
C979	HCEC0JRV2101T	CAP , CHIP ELECT	100UF/6.3V	1	EA
C980	HCEC0JRV2220T	CAP , CHIP ELECT	22UF/6.3V	1	EA
C991	CCUS1H104KC	CAP , CHIP	0.1UF	1	EA
C992	CCUS1H104KC	CAP , CHIP	0.1UF	1	EA
C993	CCUS1H104KC	CAP , CHIP	0.1UF	1	EA
C994	CCUS1H104KC	CAP , CHIP	0.1UF	1	EA
<i>Semiconductors</i>					
D801	HVD1SR159-200	DIODE , SCHOTTKY BARRIER	DIODE	1	EA
D811	CVDAD1580BRT	I.C, 1.2V MICROPOWER,PRECISION	MICROPOWER	1	EA
D926	CVD1SS378	DIODE , SCHOTTKY BARRIER	DIODE	1	EA
D927	CVD1SS378	DIODE , SCHOTTKY BARRIER	DIODE	1	EA
IC71	HVIKIC7SZ08FU	I.C ,INPUT AND GATE	KEC	1	EA
IC72	CVI74LCX74TTR	I.C, D-FLIP FLOP	ST	1	EA
IC78	CVIST232CDR	I.C , RS232C TRANSCEIVER	ST	1	EA
IC79	HVIKIC7SZ08FU	I.C ,INPUT AND GATE	KEC	1	EA
IC80	CVIST25VF080B504CS2	I.C , 8 Mbit SPI Serial Flash	SST	1	EA
IC81	CVIM24C32WMN6TP	I.C , EEPROM (32 Kbit)	ST	1	EA
IC82	CVIFLI8125LFBC	I.C , HUDSON FAMILY	GENESIS	1	EA
IC83	CVIADV7322KSTZ	I.C , VIDEO ENCODER	ANALOG DEVICES	1	EA
IC84	CVINJM2566V	I.C , NJM2566AV(TE1)	JRC	1	EA
IC85	HVINJM2391DL133	I.C , CHIP REGULATOR (+3.3V)	JRC	1	EA

Ref. Designator	Part Number	Description		Qty	
HUDSON (HDMI) PCB (CUP11915)					
IC86	HVINJM2391DL125	I.C , CHIP REGULATOR (+2.5V)	JRC	1	EA
IC87	CVINJM2845DL118	I.C , CHIP REGULATOR (+1.8V)	JRC	1	EA
IC88	CVIIDTQS3VH16233PA	I.C , 32:16 BUS SWITCH	IDT	1	EA
IC89	CVIIDTQS3VH16233PA	I.C , 32:16 BUS SWITCH	IDT	1	EA
IC90	HVINJM2391DL133	I.C , CHIP REGULATOR (+3.3V)	JRC	1	EA
IC91	CVISII9031CTU7	I.C , HDMI RX	SILICON IMAGE	1	EA
IC92	CVISII9030CTU7	I.C , HDMI TX	SILICON IMAGE	1	EA
IC93	HVI74VHC08TTR	I.C , AND-GATE	ST	1	EA
IC94	CVITC7MZ4052FK	I.C , 4CH MUX	TOSHIBA	1	EA
IC95	CVIAT24C02NSU18	I.C, EEPROM (2K)	ATMEL	1	EA
IC96	CVITC7MZ4052FK	I.C , 4CH MUX	TOSHIBA	1	EA
IC97	CVIAT24C02NSU18	I.C, EEPROM (2K)	ATMEL	1	EA
IC98	HVIRN5RZ50BA	REGULATOR 5V (SOT-23-5)	RICOH	1	EA
IC99	CVINJM2845DL118	IC, CHIP REGULATOR(1.8V)	JRC	1	EA
Q902	CVTKRC103S	TRANSISTOR , PNP, CHIP	KRC103S	1	EA
Q903	HVTKRA102S	TRANSISTOR , PNP, CHIP	KRA102S	1	EA
Q904	CVTKRC103S	TRANSISTOR , PNP, CHIP	KRC103S	1	EA
Q905	HVTKRA102S	TRANSISTOR , PNP, CHIP	KRA102S	1	EA
Q906	CVTKRC103S	TRANSISTOR , PNP, CHIP	KRC103S	1	EA
Q907	CVTKRC103S	TRANSISTOR , PNP, CHIP	KRC103S	1	EA
Q908	CVTUPA672T	N-CHANNEL MOS FET ARRAY	UPA672T	1	EA
Q909	CVTUPA672T	N-CHANNEL MOS FET ARRAY	UPA672T	1	EA
Q910	CVTUPA672T	N-CHANNEL MOS FET ARRAY	UPA672T	1	EA
<i>Resistors</i>					
RN80	CRJ104DJ220T	RES , 4ARRAY (1608*4)	22 OHM/1608*4	1	EA
RN81	CRJ104DJ220T	RES , 4ARRAY (1608*4)	22 OHM/1608*4	1	EA
RN82	CRJ104DJ220T	RES , 4ARRAY (1608*4)	22 OHM/1608*4	1	EA
RN83	CRJ104DJ220T	RES , 4ARRAY (1608*4)	22 OHM/1608*4	1	EA
RN84	CRJ104DJ220T	RES , 4ARRAY (1608*4)	22 OHM/1608*4	1	EA
RN85	CRJ104DJ220T	RES , 4ARRAY (1608*4)	22 OHM/1608*4	1	EA
RN86	CRJ104DJ220T	RES , 4ARRAY (1608*4)	22 OHM/1608*4	1	EA
RN87	CRJ104DJ220T	RES , 4ARRAY (1608*4)	22 OHM/1608*4	1	EA
RN88	CRJ104DJ220T	RES , 4ARRAY (1608*4)	22 OHM/1608*4	1	EA
RN89	CRJ104DJ220T	RES , 4ARRAY (1608*4)	22 OHM/1608*4	1	EA
RN91	CRJ104DJ220T	RES , 4ARRAY (1608*4)	22 OHM/1608*4	1	EA
RN92	CRJ104DJ220T	RES , 4ARRAY (1608*4)	22 OHM/1608*4	1	EA
RN93	CRJ104DJ220T	RES , 4ARRAY (1608*4)	22 OHM/1608*4	1	EA
RN94	CRJ104DJ220T	RES , 4ARRAY (1608*4)	22 OHM/1608*4	1	EA
RN95	CRJ104DJ220T	RES , 4ARRAY (1608*4)	22 OHM/1608*4	1	EA
RN96	CRJ104DJ220T	RES , 4ARRAY (1608*4)	22 OHM/1608*4	1	EA
RN97	CRJ104DJ100T	RES , 4ARRAY (1608*4)	10 OHM/1608*4	1	EA
R522	CRJ10DJ301T	RES , CHIP	300 OHM	1	EA
R801	CRJ10DJ272T	RES , CHIP	2.7K OHM	1	EA
R802	CRJ10DJ272T	RES , CHIP	2.7K OHM	1	EA
R803	CRJ10DJ473T	RES , CHIP	47K OHM	1	EA
R804	CRJ10DJ103T	RES , CHIP	10K OHM	1	EA
R805	CRJ10DJ102T	RES , CHIP	1K OHM	1	EA
R806	CRJ10DJ103T	RES , CHIP	10K OHM	1	EA
R807	CRJ10DJ103T	RES , CHIP	10K OHM	1	EA
R809	CRJ10DJ103T	RES , CHIP	10K OHM	1	EA
R810	CRJ10DJ222T	RES , CHIP	10K OHM	1	EA
R811	CRJ10DJ103T	RES , CHIP	10K OHM	1	EA
R812	CRJ10DJ103T	RES , CHIP	10K OHM	1	EA
R813	CRJ10DJ103T	RES , CHIP	10K OHM	1	EA
R814	CRJ10DJ103T	RES , CHIP	10K OHM	1	EA
R815	CRJ10DJ220T	RES , CHIP	22 OHM	1	EA
R816	CRJ10DJ560T	RES , CHIP	56 OHM	1	EA
R817	CRJ10DJ220T	RES , CHIP	22 OHM	1	EA
R818	CRJ10DJ220T	RES , CHIP	22 OHM	1	EA

Ref. Designator	Part Number	Description		Qty	
HUDSON (HDMI) PCB (CUP11915)					
R819	CRJ10DJ220T	RES , CHIP	22 OHM	1	EA
R820	CRJ10DJ560T	RES , CHIP	56 OHM	1	EA
R821	CRJ10DJ560T	RES , CHIP	56 OHM	1	EA
R822	CRJ10DJ220T	RES , CHIP	22 OHM	1	EA
R823	CRJ10DJ220T	RES , CHIP	22 OHM	1	EA
R824	CRJ10DJ560T	RES , CHIP	56 OHM	1	EA
R825	CRJ10DJ103T	RES , CHIP	10K OHM	1	EA
R826	CRJ10DJ112T	RES , CHIP	1.1K OHM	1	EA
R827	CRJ10DJ302T	RES , CHIP	3K OHM	1	EA
R828	CRJ10DJ302T	RES , CHIP	3K OHM	1	EA
R829	CRJ10DJ681T	RES , CHIP	680 OHM	1	EA
R830	CRJ10DJ681T	RES , CHIP	680 OHM	1	EA
R831	CRJ10DJ100T	RES , CHIP	10 OHM	1	EA
R832	CRJ10DJ100T	RES , CHIP	10 OHM	1	EA
R833	CRJ10DJ100T	RES , CHIP	10 OHM	1	EA
R834	CRJ10DJ472T	RES , CHIP	4.7K OHM	1	EA
R835	CRJ10DJ472T	RES , CHIP	4.7K OHM	1	EA
R836	CRJ10DJ103T	RES , CHIP	10K OHM	1	EA
R837	CRJ10DJ103T	RES , CHIP	10K OHM	1	EA
R838	CRJ10DJ103T	RES , CHIP	10K OHM	1	EA
R839	CRJ10DJ1R0T	RES , CHIP	1 OHM	1	EA
R841	CRJ10DJ272T	RES , CHIP	2.7K OHM	1	EA
R842	CRJ10DJ272T	RES , CHIP	2.7K OHM	1	EA
R843	CRJ10DJ272T	RES , CHIP	2.7K OHM	1	EA
R844	CRJ10DJ272T	RES , CHIP	2.7K OHM	1	EA
R851	CRJ10DJ301T	RES , CHIP	300 OHM	1	EA
R853	CRJ10DJ301T	RES , CHIP	300 OHM	1	EA
R854	CRJ10DJ301T	RES , CHIP	300 OHM	1	EA
R855	CRJ10DJ272T	RES , CHIP	2.7K OHM	1	EA
R856	CRJ10DJ301T	RES , CHIP	300 OHM	1	EA
R857	CRJ10DJ301T	RES , CHIP	300 OHM	1	EA
R858	CRJ10DJ103T	RES , CHIP	10K OHM	1	EA
R859	CRJ10DJ103T	RES , CHIP	10K OHM	1	EA
R871	CRJ10DJ5R6T	RES , CHIP	5.6 OHM	1	EA
R872	CRJ10DJ100T	RES , CHIP	10 OHM	1	EA
R873	CRJ10DJ9R1T	RES , CHIP	9.1 OHM	1	EA
R874	CRJ10DJ750T	RES , CHIP	75 OHM	1	EA
R875	CRJ10DJ750T	RES , CHIP	75 OHM	1	EA
R876	CRJ10DJ750T	RES , CHIP	75 OHM	1	EA
R880	CRJ10DJ680T	RES , CHIP	68 OHM	1	EA
R881	CRJ10DJ820T	RES , CHIP	82 OHM	1	EA
R882	CRJ10DJ820T	RES , CHIP	82 OHM	1	EA
R907	CRJ10DJ102T	RES , CHIP	1K OHM	1	EA
R908	CRJ10DJ223T	RES , CHIP	22K OHM	1	EA
R909	CRJ10DJ101T	RES , CHIP	100 OHM	1	EA
R910	CRJ10DJ101T	RES , CHIP	100 OHM	1	EA
R911	CRJ10DJ101T	RES , CHIP	100 OHM	1	EA
R912	CRJ10DJ101T	RES , CHIP	100 OHM	1	EA
R913	CRJ10DJ102T	RES , CHIP	1K OHM	1	EA
R914	CRJ10DJ223T	RES , CHIP	22K OHM	1	EA
R915	CRJ10DJ103T	RES , CHIP	10K OHM	1	EA
R916	CRJ10DJ473T	RES , CHIP	47K OHM	1	EA
R917	CRJ10DJ103T	RES , CHIP	10K OHM	1	EA
R918	CRJ10DJ103T	RES , CHIP	10K OHM	1	EA
R919	CRJ10DJ103T	RES , CHIP	10K OHM	1	EA
R920	CRJ10DJ473T	RES , CHIP	47K OHM	1	EA
R921	CRJ10DJ103T	RES , CHIP	10K OHM	1	EA
R922	CRJ10DJ103T	RES , CHIP	10K OHM	1	EA
R923	CRJ10DJ181T	RES , CHIP	180 OHM	1	EA
R928	CRJ10DJ101T	RES , CHIP	100 OHM	1	EA
R929	CRJ10DJ101T	RES , CHIP	100 OHM	1	EA

Ref. Designator	Part Number	Description		Qty	
HUDSON (HDMI) PCB (CUP11915)					
R933	CRJ10DJ332T	RES , CHIP	3.3K OHM	1	EA
R934	CRJ10DJ332T	RES , CHIP	3.3K OHM	1	EA
R935	CRJ10DJ332T	RES , CHIP	3.3K OHM	1	EA
R936	CRJ10DJ473T	RES , CHIP	47K OHM	1	EA
R937	CRJ10DJ101T	RES , CHIP	100 OHM	1	EA
R938	CRJ10DJ101T	RES , CHIP	100 OHM	1	EA
R939	CRJ10DJ473T	RES , CHIP	47K OHM	1	EA
R940	CRJ10DJ473T	RES , CHIP	47K OHM	1	EA
R941	CRJ10DJ101T	RES , CHIP	100 OHM	1	EA
R942	CRJ10DJ220T	RES , CHIP	22 OHM	1	EA
R943	CRJ10DJ220T	RES , CHIP	22 OHM	1	EA
R944	CRJ10DJ220T	RES , CHIP	22 OHM	1	EA
R945	CRJ10DJ330T	RES , CHIP	33 OHM	1	EA
R946	CRJ10DJ105T	RES , CHIP	1M OHM	1	EA
R947	CRJ10DJ103T	RES , CHIP	10K OHM	1	EA
R948	CRJ10DJ103T	RES , CHIP	10K OHM	1	EA
R949	CRJ10DJ182T	RES , CHIP	1.8K OHM	1	EA
R950	CRJ10DJ103T	RES , CHIP	10K OHM	1	EA
R951	CRJ10DJ182T	RES , CHIP	1.8K OHM	1	EA
R952	CRJ10DJ182T	RES , CHIP	1.8K OHM	1	EA
R953	CRJ10DJ471T	RES , CHIP	470 OHM	1	EA
R962	CRJ10DJ101T	RES , CHIP	100 OHM	1	EA
R963	CRJ10DJ103T	RES , CHIP	10K OHM	1	EA
R964	CRJ10DJ101T	RES , CHIP	100 OHM	1	EA
R966	CRJ10DJ222T	RES , CHIP	2.2K OHM	1	EA
R967	CRJ10DJ222T	RES , CHIP	2.2K OHM	1	EA
R975	CRJ10DJ473T	RES , CHIP	47K OHM	1	EA
R976	CRJ10DJ473T	RES , CHIP	47K OHM	1	EA
J801	CRD25TJ100T	RES , CARBON	10 OHM/ 1/4W	1	EA
J802	CRD25TJ100T	RES , CARBON	10 OHM/ 1/4W	1	EA
<i>Miscellaneous</i>					
X801	COX19660E330S	CRYSTAL , CHIP(SMD)	19.6608 MHz	1	EA
X901	HOX27000E180S	CRYSTAL , CHIP(SMD)	27MHz	1	EA
CN80	CJP03GA19ZY	WAFER, STRAIGHT, 3PIN	WAFER	1	EA
	CHG1A306	CUSHION	CUSHION	2	EA
CN81	CJP44HA187ZY	WAFER, HOUSING 44PIN	WAFER	1	EA
JK91	HJJ9H003Z	JACK,HDMI (JALCO)	JACK	1	EA
JK92	HJJ9H003Z	JACK,HDMI (JALCO)	JACK	1	EA
JK93	HJJ9H003Z	JACK,HDMI (JALCO)	JACK	1	EA
L801	HLZ9R006Z	CHIP , BEAD	HH-1H2012-221JT	1	EA
L802	HLZ9Z014Z	CHIP , BEAD	HU-1H4516-600JT	1	EA
L803	HLZ9R006Z	CHIP , BEAD	HH-1H2012-221JT	1	EA
L804	HLZ9Z014Z	CHIP , BEAD	HU-1H4516-600JT	1	EA
L805	HLZ9Z014Z	CHIP , BEAD	HU-1H4516-600JT	1	EA
L806	HLZ9R006Z	CHIP , BEAD	HH-1H2012-221JT	1	EA
L807	HLZ9R006Z	CHIP , BEAD	HH-1H2012-221JT	1	EA
L808	HLZ9R006Z	CHIP , BEAD	HH-1H2012-221JT	1	EA
L809	HLZ9R006Z	CHIP , BEAD	HH-1H2012-221JT	1	EA
L810	HLZ9Z014Z	CHIP , BEAD	HU-1H4516-600JT	1	EA
L811	HLZ9R006Z	CHIP , BEAD	HH-1H2012-221JT	1	EA
L812	HLZ9Z014Z	CHIP , BEAD	HU-1H4516-600JT	1	EA
L813	HLZ9Z014Z	CHIP , BEAD	HU-1H4516-600JT	1	EA
L814	HLZ9Z014Z	CHIP , BEAD	HU-1H4516-600JT	1	EA
L816	HLZ9Z014Z	CHIP , BEAD	HU-1H4516-600JT	1	EA
L817	HLZ9Z014Z	CHIP , BEAD	HU-1H4516-600JT	1	EA
L901	HLZ9Z014Z	CHIP , BEAD	HU-1H4516-600JT	1	EA
L902	HLZ9Z014Z	CHIP , BEAD	HU-1H4516-600JT	1	EA
L903	HLZ9Z014Z	CHIP , BEAD	HU-1H4516-600JT	1	EA
L904	HLZ9Z014Z	CHIP , BEAD	HU-1H4516-600JT	1	EA

Ref. Designator	Part Number	Description		Qty	
HUDSON (HDMI) PCB (CUP11915)					
L921	CLZ9R009Z	CHOKE COIL, CHIP (FOR HDMI)	TDK	1	EA
L922	CLZ9R009Z	CHOKE COIL, CHIP (FOR HDMI)	TDK	1	EA
L923	CLZ9R009Z	CHOKE COIL, CHIP (FOR HDMI)	TDK	1	EA
L924	CLZ9R009Z	CHOKE COIL, CHIP (FOR HDMI)	TDK	1	EA
XM PCB (CUP11913-4)					
<i>Capacitors</i>					
C408	HCEC1CRV2101T	CAP , ELEC (SMD)	100UF/16V	1	EA
C409	CCUS1H104KC	CAP , CHIP	0.1UF	1	EA
C418	HCEC1CRV2101T	CAP , ELEC (SMD)	100UF/16V	1	EA
C419	CCUS1H104KC	CAP , CHIP	0.1UF	1	EA
C455	CCUS1H104KC	CAP , CHIP	0.1UF	1	EA
C456	CCUS1H104KC	CAP , CHIP	0.1UF	1	EA
C457	HCEC1CRV2100T	CAP , ELEC (SMD)	10UF / 16V	1	EA
C458	HCEC1CRV2100T	CAP , ELEC (SMD)	10UF / 16V	1	EA
C460	CCUS1H102KC	CAP , CHIP	1000PF	1	EA
C461	CCUS1H102KC	CAP , CHIP	1000PF	1	EA
C462	CCUS1H271JA	CAP , CHIP	270PF	1	EA
C463	CCUS1H271JA	CAP , CHIP	270PF	1	EA
C464	CCUS1H223KC	CAP , CHIP	0.022UF	1	EA
C466	HCEC1CRV2100T	CAP , ELEC (SMD)	10UF / 16V	1	EA
C481	CCUS1H102KC	CAP , CHIP	1000PF	1	EA
C482	CCUS1H102KC	CAP , CHIP	1000PF	1	EA
C483	CCUS1H102KC	CAP , CHIP	1000PF	1	EA
C484	CCUS1H104KC	CAP , CHIP	0.1UF	1	EA
C485	CCUS1H102KC	CAP , CHIP	1000PF	1	EA
C486	CCUS1H104KC	CAP , CHIP	0.1UF	1	EA
C487	CCUS1H180JA	CAP , CHIP	18PF	1	EA
C488	CCUS1H180JA	CAP , CHIP	18PF	1	EA
C489	CCUS1H104KC	CAP , CHIP	0.1UF	1	EA
C490	HCEC1CRV2100T	CAP , ELEC (SMD)	10UF / 16V	1	EA
C491	HCEC1CRV2220T	CAP , ELEC (SMD)	22UF/16V	1	EA
C492	HCEC1CRV2100T	CAP , ELEC (SMD)	10UF / 16V	1	EA
C493	HCEC1CRV2100T	CAP , ELEC (SMD)	10UF / 16V	1	EA
C494	CCUS1H331JA	CAP , CHIP	330PF	1	EA
C495	CCUS1H331JA	CAP , CHIP	330PF	1	EA
C496	CCUS1H223KC	CAP , CHIP	0.022UF	1	EA
C497	CCUS1H122KC	CAP , CHIP	1200PF	1	EA
C498	CCUS1H122KC	CAP , CHIP	1200PF	1	EA
C499	HCEC1CRV2100T	CAP , ELEC (SMD)	10UF / 16V	1	EA
C502	CCUS1H104KC	CAP , CHIP	0.1UF	1	EA
C503	CCUS1H104KC	CAP , CHIP	0.1UF	1	EA
C504	CCUS1H181JA	CAP , CHIP	180PF	1	EA
C505	CCUS1H104KC	CAP , CHIP	0.1UF	1	EA
C506	CCUS1H104KC	CAP , CHIP	0.1UF	1	EA
C507	CCUS1H104KC	CAP , CHIP	0.1UF	1	EA
C508	CCUS1H104KC	CAP , CHIP	0.1UF	1	EA
C509	CCUS1H104KC	CAP , CHIP	0.1UF	1	EA
C510	CCUS1H104KC	CAP , CHIP	0.1UF	1	EA
C511	CCUS1H104KC	CAP , CHIP	0.1UF	1	EA
C512	HCEC1CRV2220T	CAP , ELEC (SMD)	22UF/16V	1	EA
C517	CCUS1H104KC	CAP , CHIP	0.1UF	1	EA
C518	CCUS1H104KC	CAP , CHIP	0.1UF	1	EA
C526	CCEA1CKS101T	CAP , ELECT	100UF 16V	1	EA
<i>Semiconductors</i>					
D404	HVDRB160L60TE25	DIODE , SCHOTTKEY BARRIER	RB160L-60TE25	1	EA
IC51	CVIXMDTIC	I.C , XM	XM	1	EA

Ref. Designator	Part Number	Description		Qty	
XM PCB (CUP11913-4)					
IC52	CVIAK4384ET	I.C , ADC	ASAHI KASEI	1	EA
IC53	HVINJM2068MDTE1	I.C , DUAL OP AMP	JRC	1	EA
IC54	HVILM1117S-3V3	I.C , REGULATOR (3.3V)	HTC	1	EA
<i>Resistors</i>					
RN50	CRJ104DJ220T	RES , 4ARRAY (1608*4)	22 OHM/1608*4	1	EA
RN51	CRJ104DJ101T	RES , 4ARRAY (1608*4)	100 OHM/1608*4	1	EA
R408	CRJ10DJ102T	RES , CHIP	1K OHM	1	EA
R409	CRJ10DJ102T	RES , CHIP	1K OHM	1	EA
R410	CRJ10DJ332T	RES , CHIP	3.3K OHM	1	EA
R411	CRJ10DJ332T	RES , CHIP	3.3K OHM	1	EA
R412	CRJ10DJ104T	RES , CHIP	100K OHM	1	EA
R413	CRJ10DJ104T	RES , CHIP	100K OHM	1	EA
R414	CRJ10DJ101T	RES , CHIP	100 OHM	1	EA
R481	CRJ10DJ103T	RES , CHIP	10K OHM	1	EA
R482	CRJ10DJ103T	RES , CHIP	10K OHM	1	EA
R483	CRJ10DJ152T	RES , CHIP	1.5K OHM	1	EA
R484	CRJ10DJ152T	RES , CHIP	1.5K OHM	1	EA
R485	CRJ10DJ101T	RES , CHIP	100 OHM	1	EA
R486	CRJ10DJ103T	RES , CHIP	10K OHM	1	EA
R487	CRJ10DJ332T	RES , CHIP	3.3K OHM	1	EA
R488	CRJ10DJ332T	RES , CHIP	3.3K OHM	1	EA
R491	CRJ10DJ0R0T	RES , CHIP	0 OHM	1	EA
R494	CRJ10DJ0R0T	RES , CHIP	0 OHM	1	EA
R503	CRJ10CJ0R0T	RES. CHIP (1/10W)	0 OHM	1	EA
R505	CRJ10DJ223T	RES , CHIP	22K OHM	1	EA
R506	CRJ10DJ102T	RES , CHIP	1K OHM	1	EA
R507	CRJ10DJ102T	RES , CHIP	1K OHM	1	EA
R508	CRJ10DJ101T	RES , CHIP	100 OHM	1	EA
R509	CRJ10DJ101T	RES , CHIP	100 OHM	1	EA
R510	CRJ10DJ104T	RES , CHIP	100K OHM	1	EA
R511	CRJ10DJ104T	RES , CHIP	100K OHM	1	EA
R512	CRJ10DJ104T	RES , CHIP	100K OHM	1	EA
R513	CRJ10DJ104T	RES , CHIP	100K OHM	1	EA
R514	CRJ10DJ223T	RES , CHIP	22K OHM	1	EA
R515	CRJ10DJ223T	RES , CHIP	22K OHM	1	EA
R516	CRJ10DJ223T	RES , CHIP	22K OHM	1	EA
R521	CRJ10DJ223T	RES , CHIP	22K OHM	1	EA
R522	CRJ10DJ223T	RES , CHIP	22K OHM	1	EA
R523	CRJ10DJ223T	RES , CHIP	22K OHM	1	EA
R524	CRJ10DJ0R0T	RES , CHIP	0 OHM	1	EA
R525	CRJ10DJ105T	RES , CHIP	1M OHM	1	EA
R526	CRJ10DJ103T	RES , CHIP	10K OHM	1	EA
R528	CRJ10DJ223T	RES , CHIP	220K OHM	1	EA
R529	CRJ10DJ223T	RES , CHIP	220K OHM	1	EA
R530	CRJ10DJ223T	RES , CHIP	220K OHM	1	EA
<i>Miscellaneous</i>					
X501	COX45158E180S	CRYSTAL, 45.1584MHz (SMD)	45.1584MHz	1	EA
BK51	CMD1A569	BRACKET , PCB	BRACKET	1	EA
BN85	CWB1C902250BM	WIRE ASS'Y	WIRE	1	EA
CN23	KJP12GB143ZP	DIP SOCKET	DIP SOCKET	1	EA
JK51	CJJ9L006Z	JACK , XM	JACK	1	EA
BN21	CJP07GA193ZY	WAFER , CARD CABLE (SMD)	WAFER	1	EA
L403	HLZ9Z014Z	CHIP , BEAD	HU-1H4516-600JT	1	EA
L502	CLQ06E2R7KRZ	INDUCTOR, CHIP	2.7UH	1	EA
L503	HLZ9Z014Z	CHIP , BEAD	HU-1H4516-600JT	1	EA
L504	HLZ9Z014Z	CHIP , BEAD	HU-1H4516-600JT	1	EA

Ref. Designator	Part Number	Description	Qty	
	CNVM9001MS0J72L	AVR 347 TUNER MODULE		

247.0mm

168.0mm

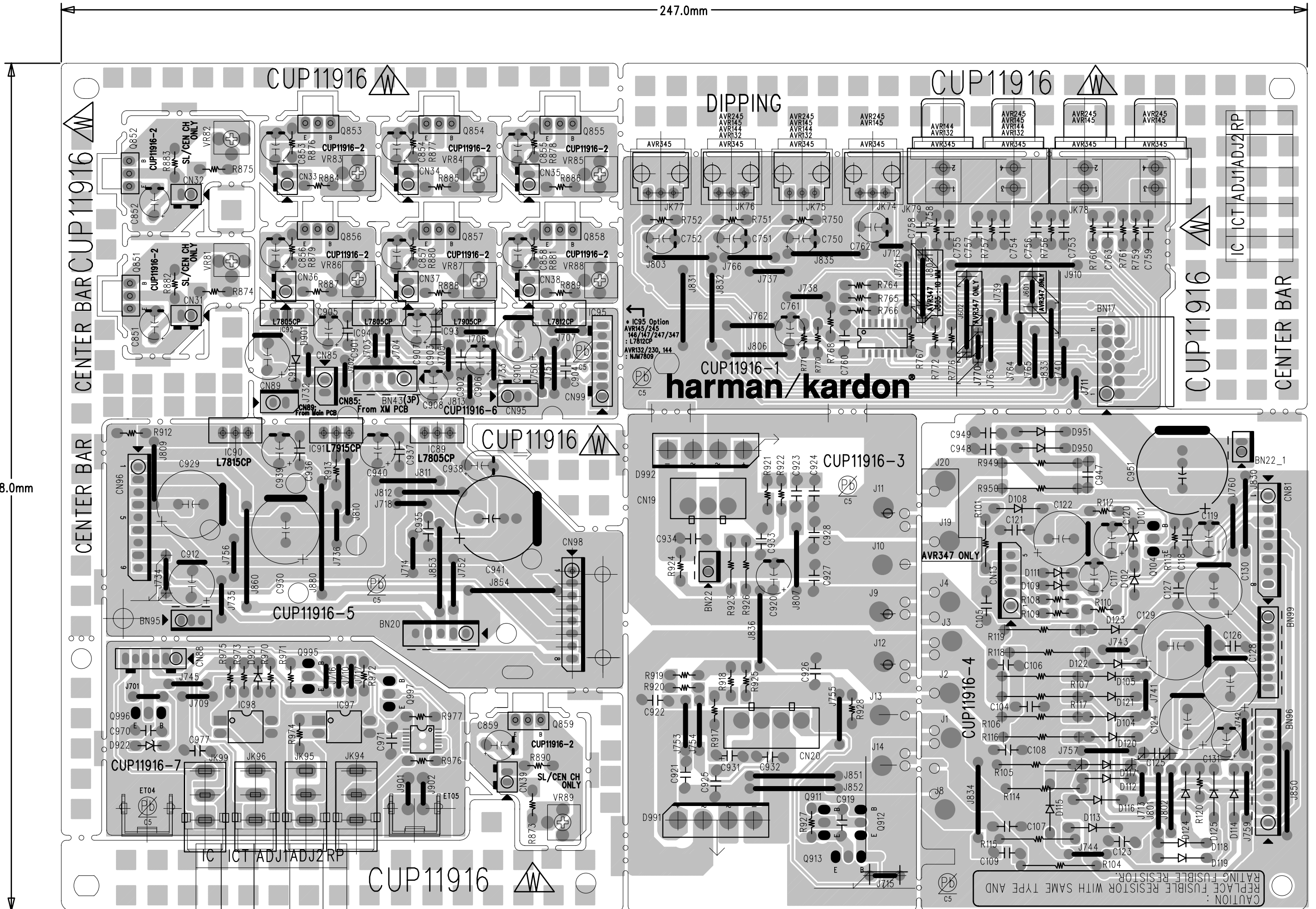

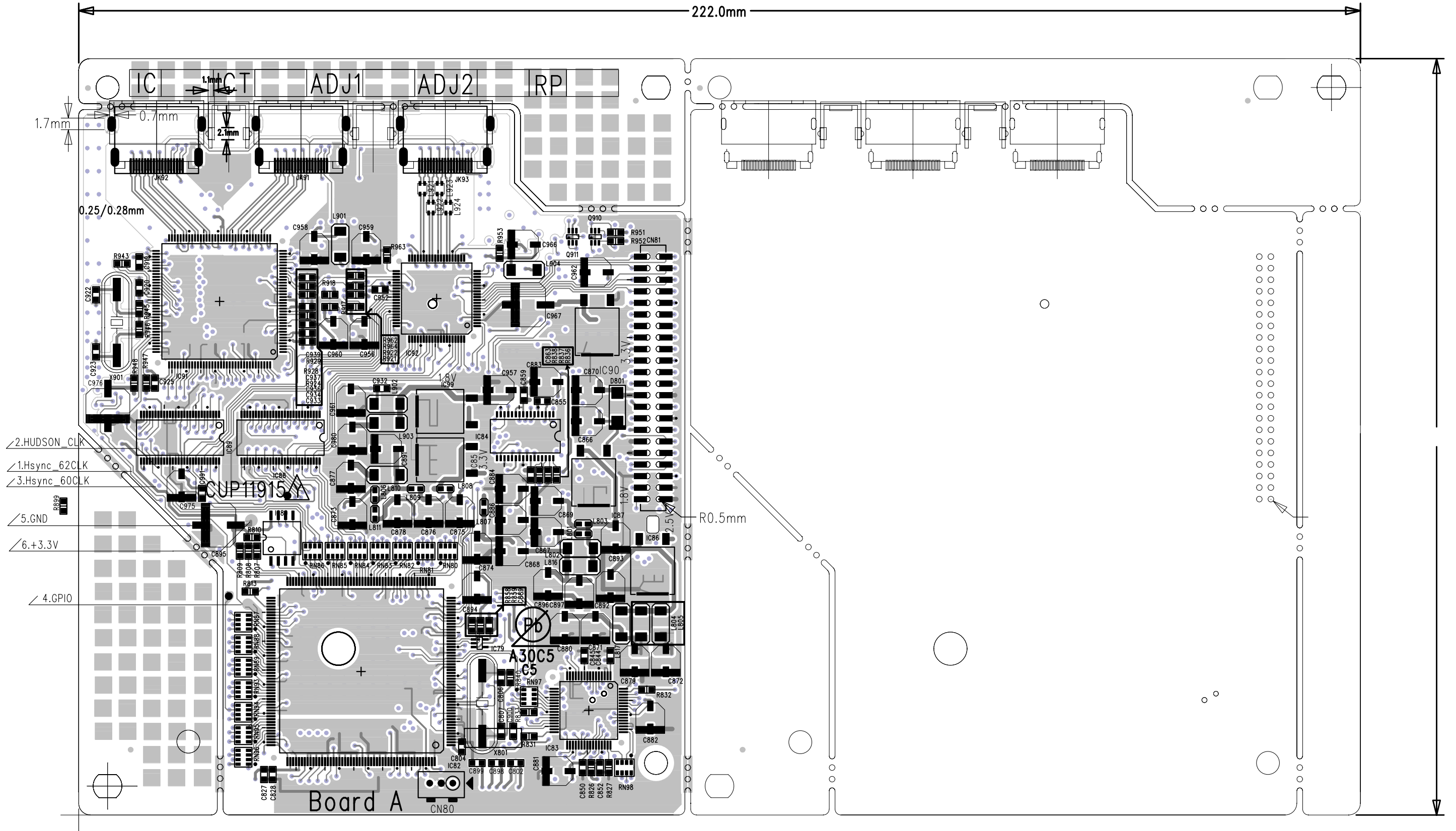

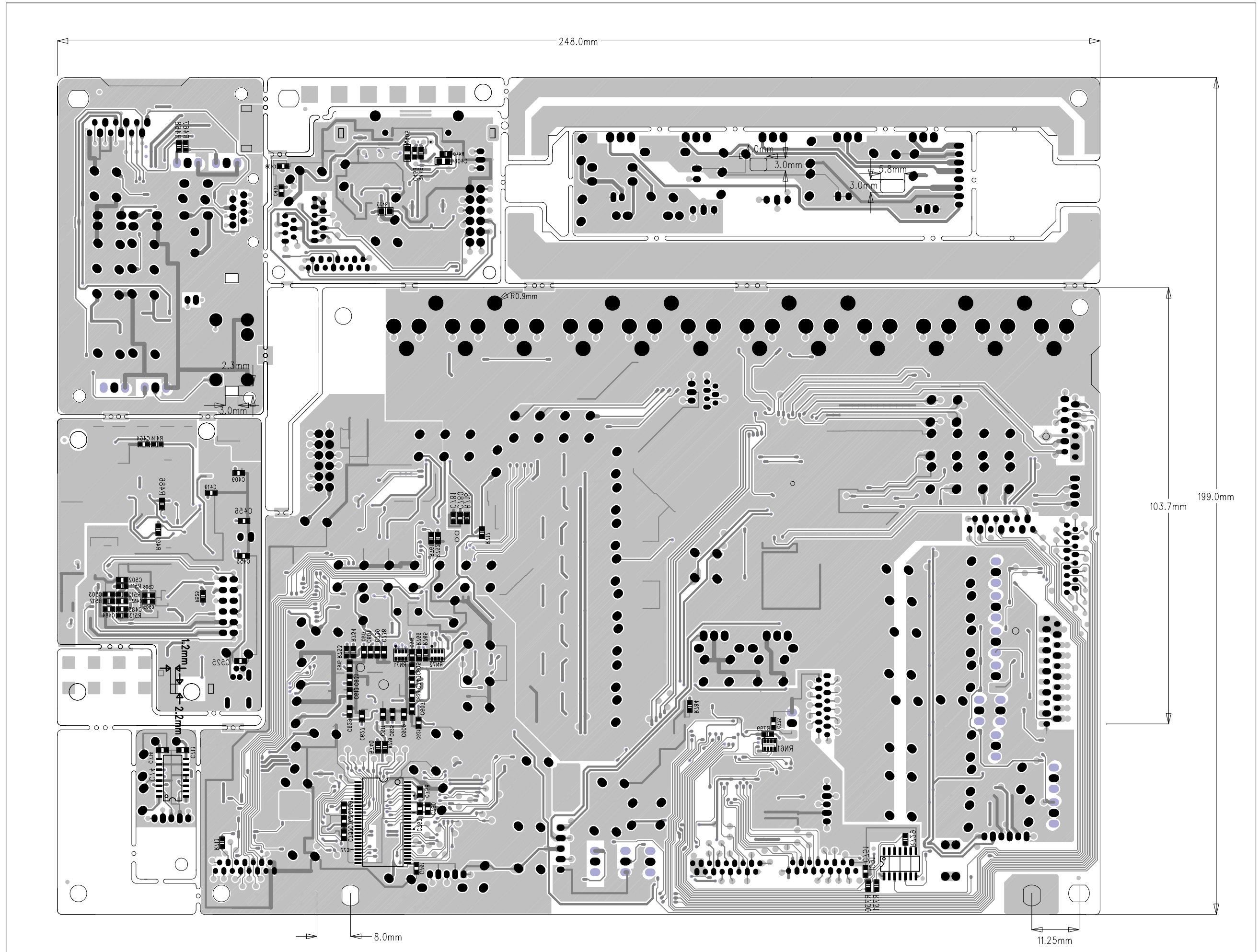

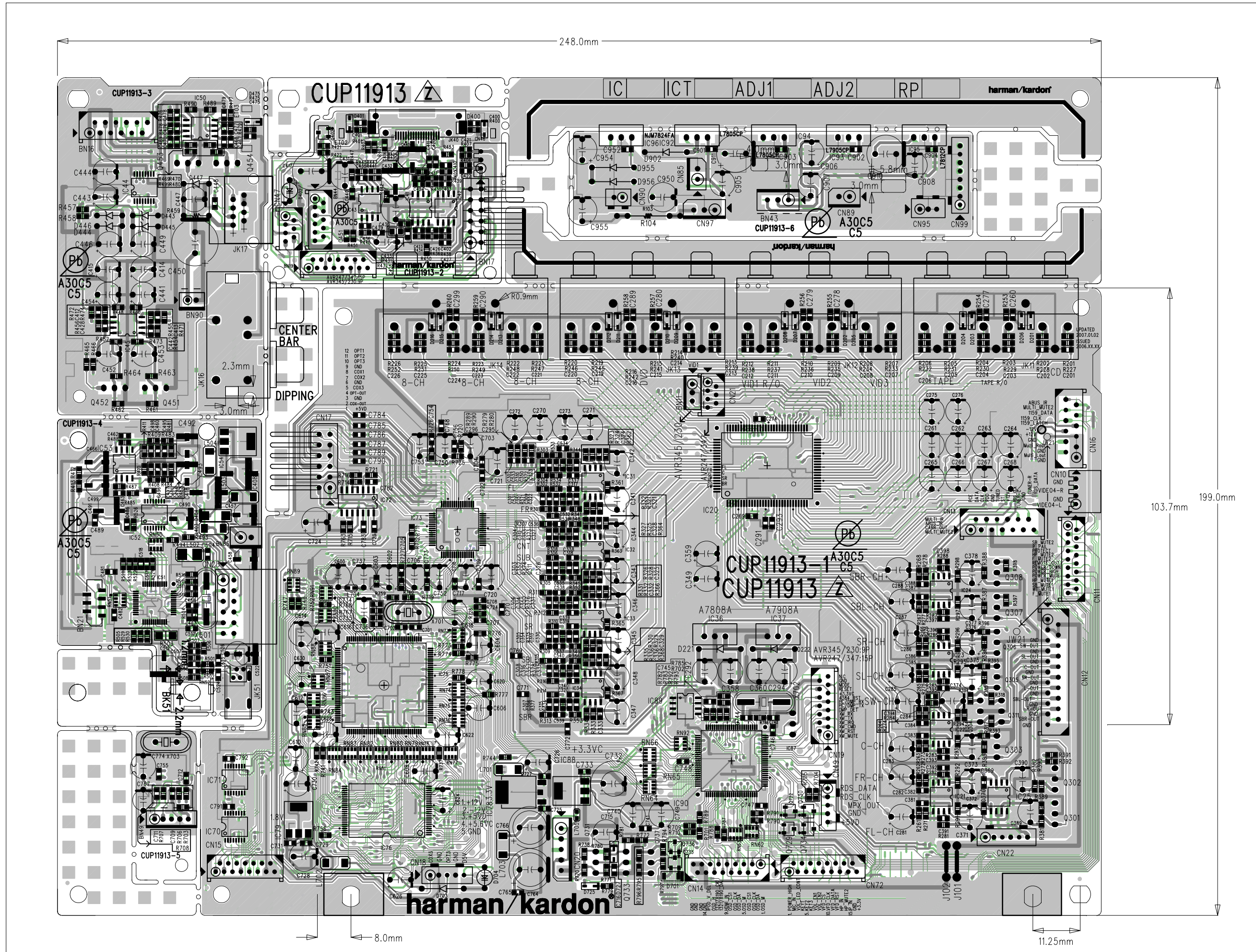

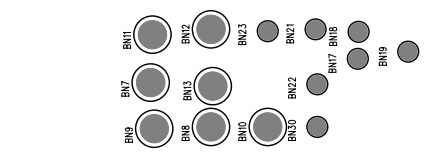
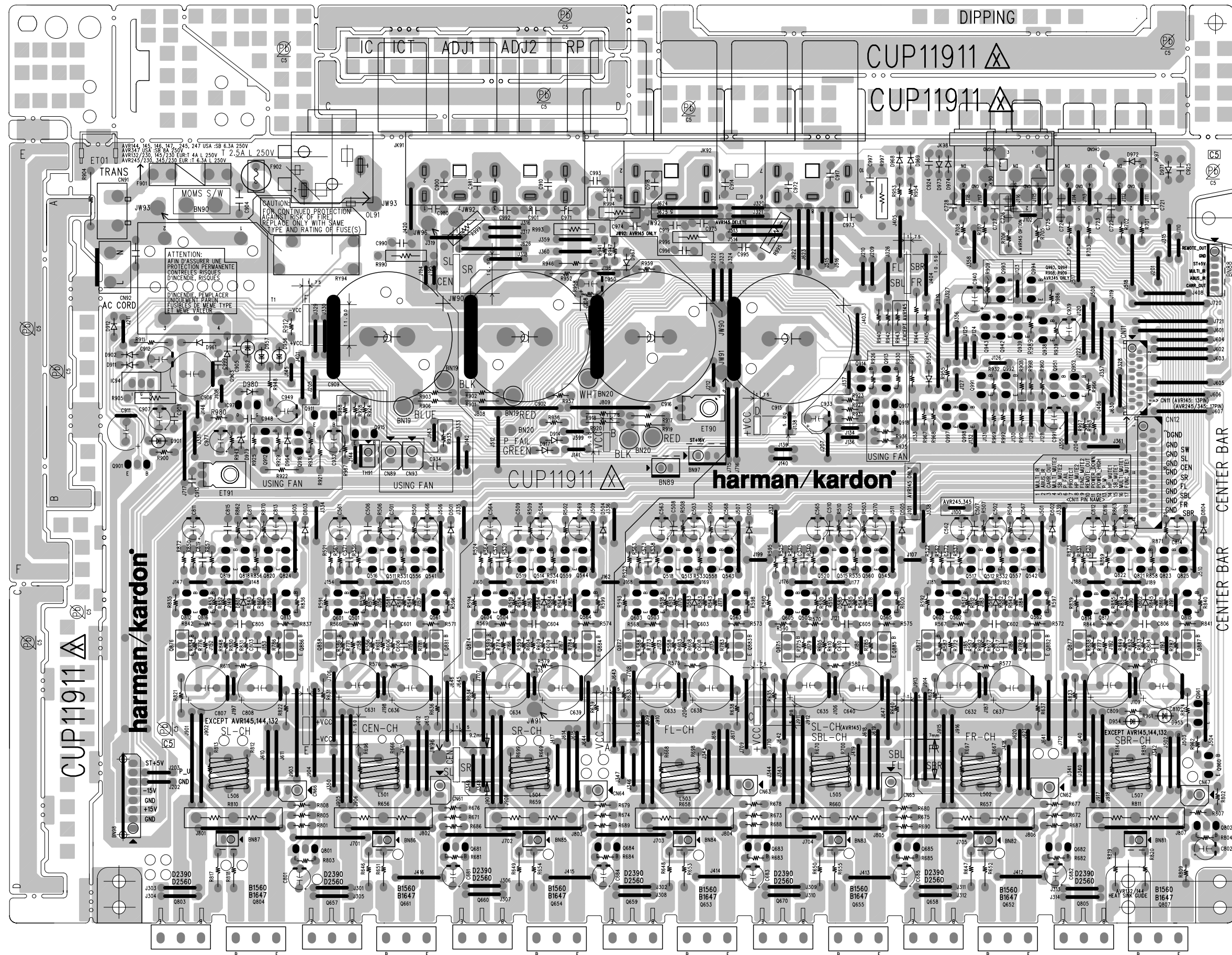

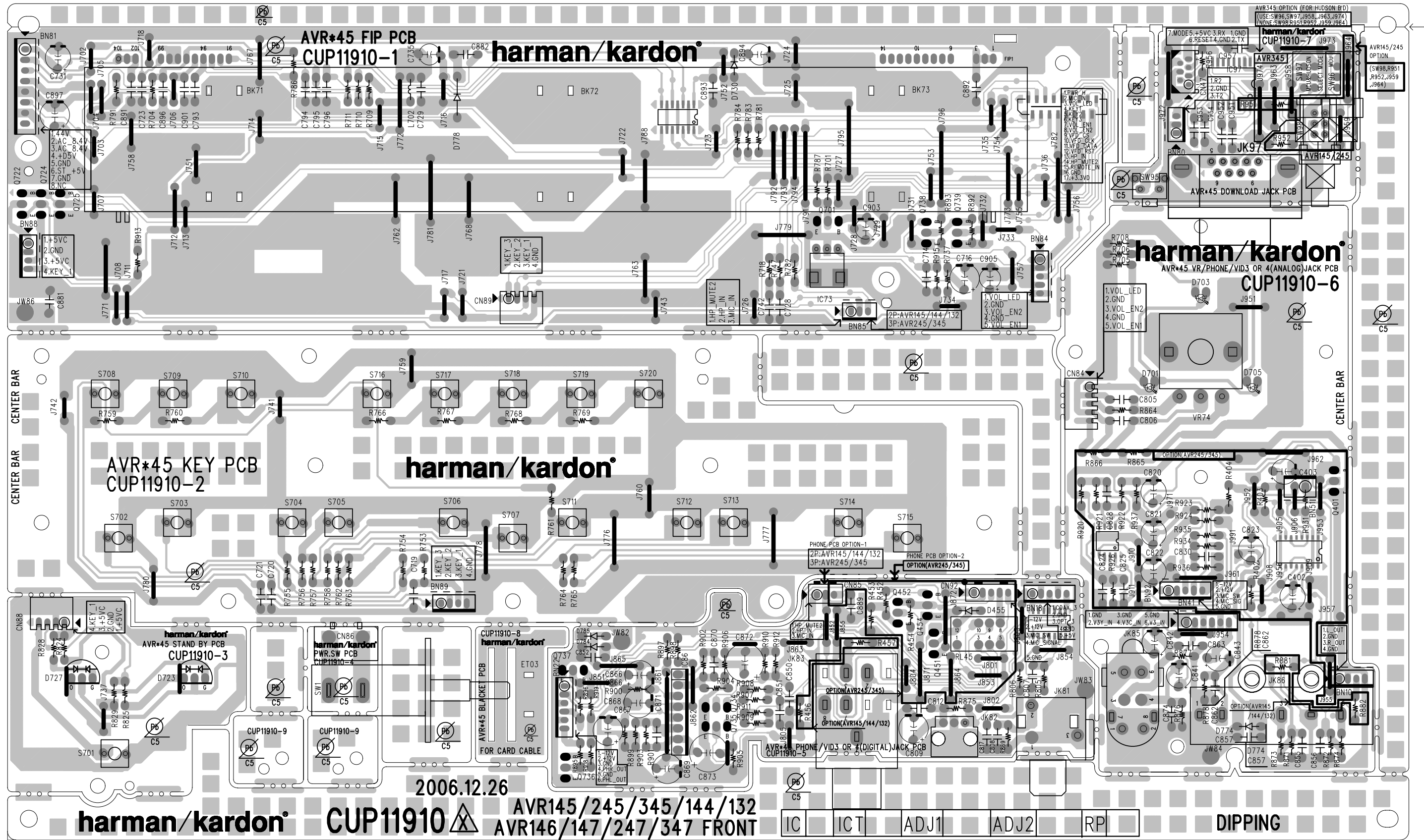

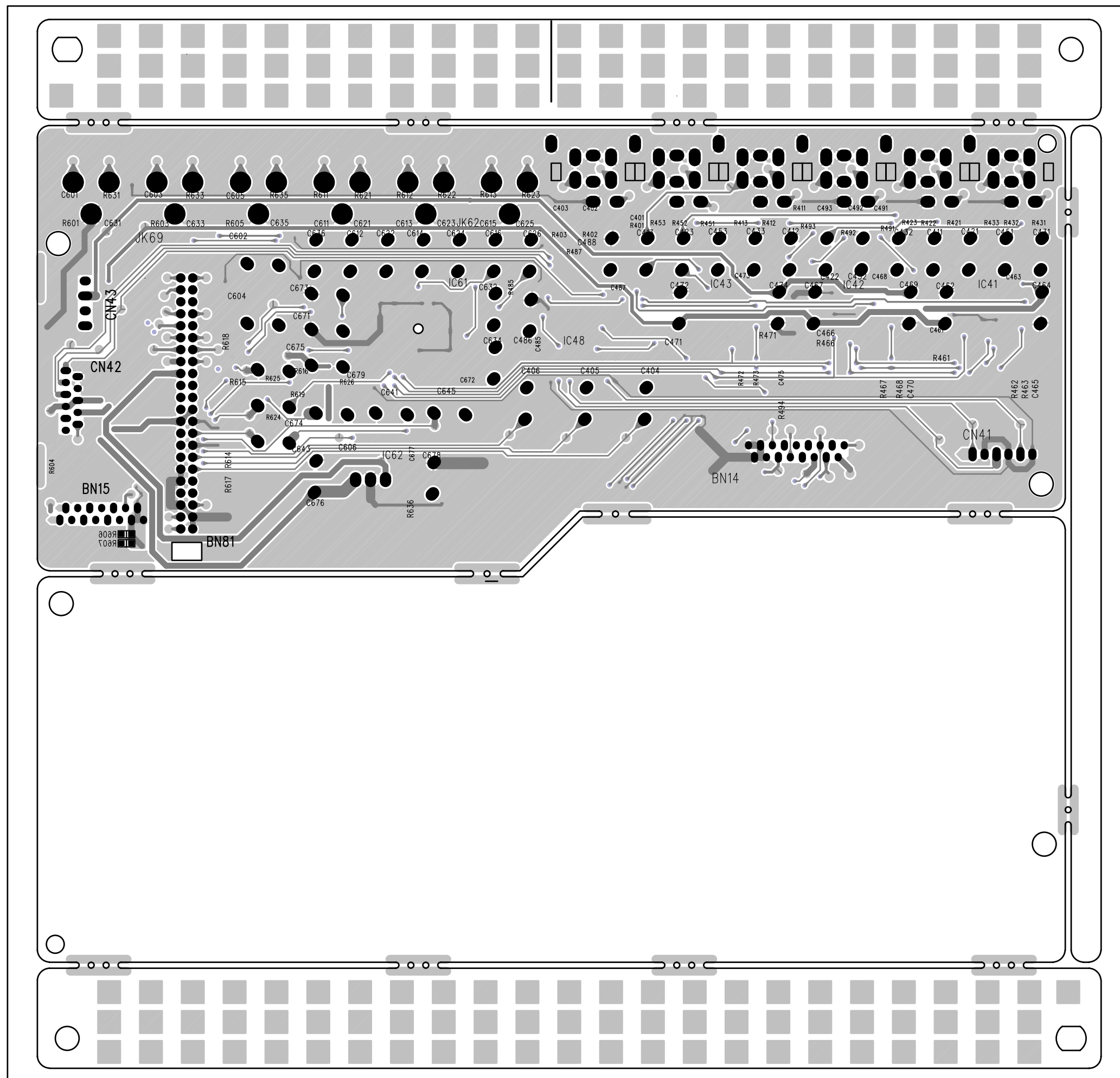

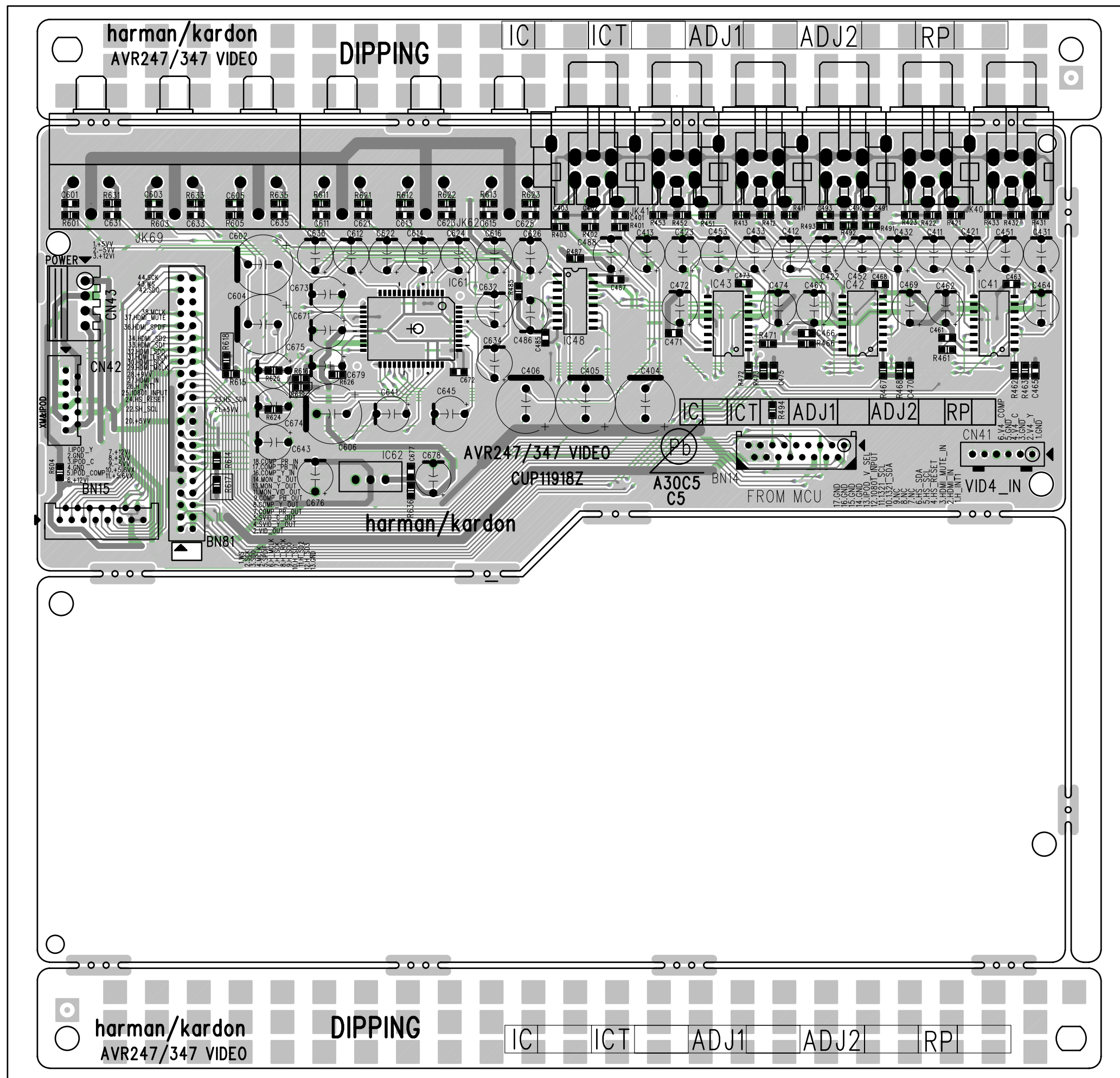

IC51 XM IC

PRELIMINARY (14 Aug 04)

User Spec - XM Digital Transceiver Integrated Circuit - Rev 3

1. Overview

The XM Digital Transceiver Integrated Circuit (XM/DT IC) provides a cost effective means for an electronics equipment manufacturer to be XM Satellite Radio compatible by multiplexing data and audio streams between the XM Receiver and User Interface Controller into a 2 wire time division duplex (TDD) high frequency serial link.

In a typical application, two XM/DT IC devices connect to each other via a differential link as depicted on Figure 1.1 below. In the 'Slave' unit ("XM/DT Digital Transceiver" (antenna)), the XM/DT IC interfaces directly to the XM Radio receiver chipset taking in a real-time PCM (I2S) audio stream along with data information. The XM/DT IC stores this data in internal RAM and then time division multiplexes the data on a 2-wire serial communication link. This link provides for the physical decoupling of the Slave and Master side of up 100 meters with software transparency

between the Master side processor and audio circuitry and the Slave side XM Satellite Radio receiver chip set.

In the Master unit ("XM/DT Ready Radio"), the XM/DT IC demultiplexes the received data, buffers it internally and reproduces it for consumption. The XM/DT IC is capable of simultaneously sending and receiving serial frames while multiplexing and de-multiplexing them in real time, formatting them and then routing them into the appropriate Slave or Master side interfaces.

The software interface between the user interface and the receiver is unaffected by the introduction of the XM/DT IC link pair.

An input pin on the XM/DT IC configures the part's functionality as either Master (user interface end) or Slave (XM Digital Transceiver end) allowing the same IC to be used at either end of the link.

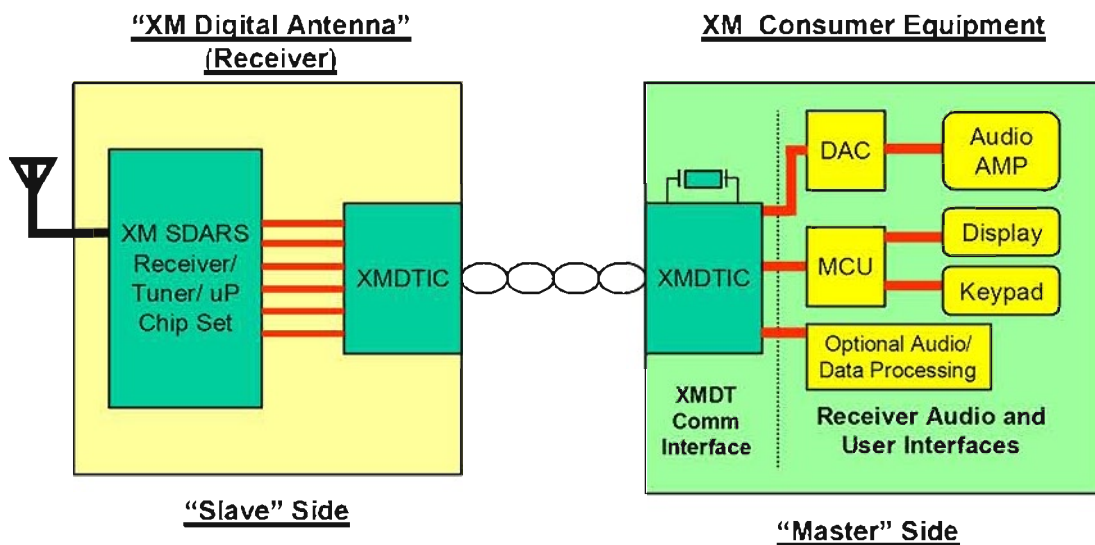

Figure 1.1 - Typical XM/DT Application

2. Functional Description

Figure 2.1 below shows a basic top level diagram showing each functional block in the XM/DT device.

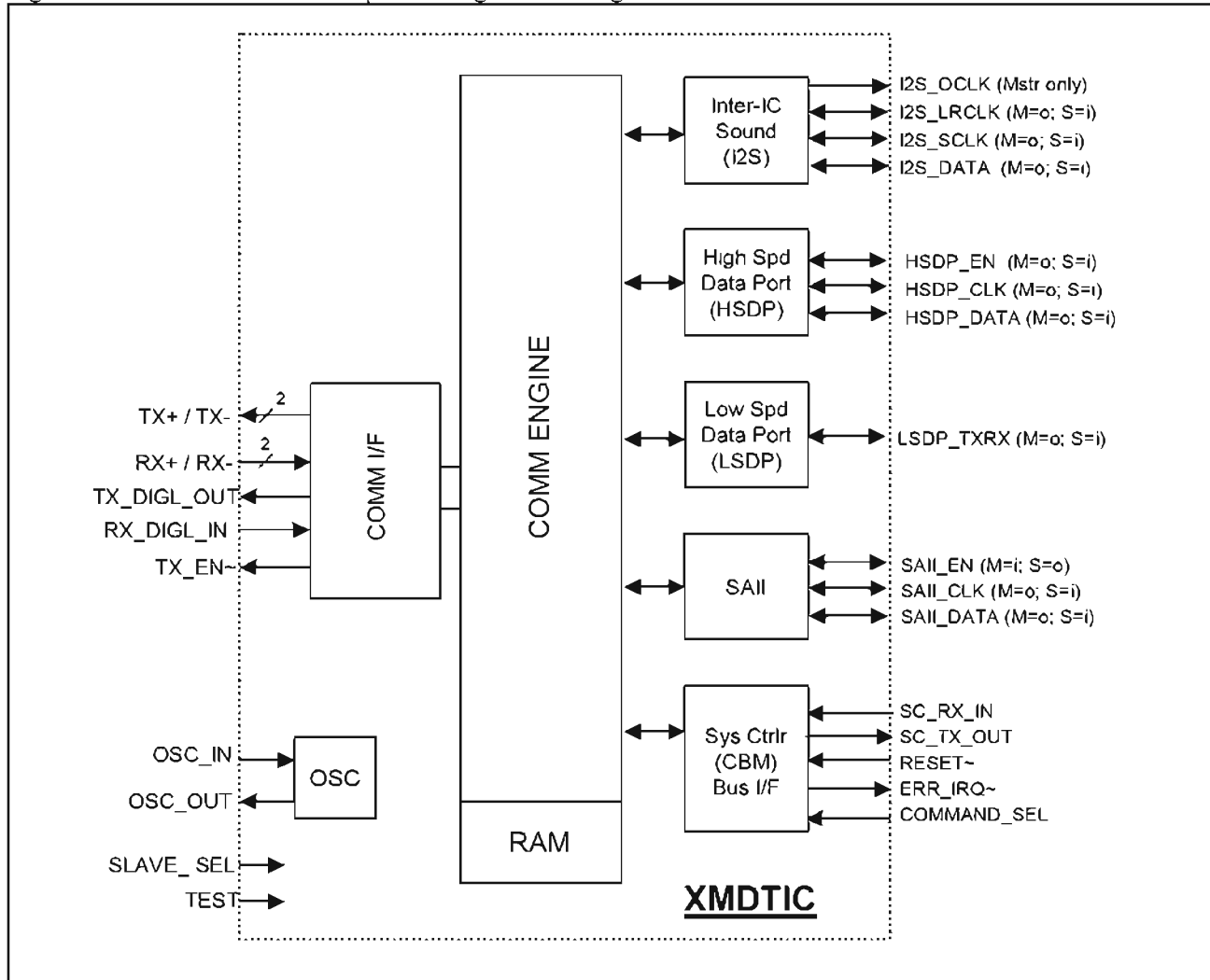

Figure 2.1 XM/DT Top Level Diagram

The XM/DT IC is broken into the following functional blocks:

SC I/F – System Controller Interface

The System Controller Interface transports the serial communication commands and data between the microprocessor in the user interface device and the microprocessor in the XM Digital Antenna. The commands and data transported follow typically follow the XM CBM (Common Bus Messaging) protocol.

The System Controller Interface functional block consists of a full duplex asynchronous serial interface. The SC I/F is used for both the software configuration of the XM/DT IC, monitoring of XM/DT link status, and transparent communications with the SC I/F at the other end of the communications link. The SC I/F block contains five signals, SC_RX_IN, SC_TX_OUT, COMMAND_SEL, ERR_IRQ#, and RESET#.

The SC_RX_IN and SC_TX_OUT connect the asynchronous serial communications to the respective microprocessors. The SC I/F

communicates at a default mode of 9600 baud, no parity, 8 data bits, and 1 stop bit. The baud rate can be changed using the XM/DT IC Command Mode. The Master and Slave baud rates must be set to the same rate by their respective microprocessors.

The COMMAND_SEL input allows configuration of the XM/DT IC and to retrieve feedback of the link status during normal operation. This signal is logic low for normal operation and logic high for Command/Stat Mode. Details of the operation of this signal are described in the Programming section of this specification.

The ERR_IRQ# output signal is active low when an error occurs on the link if interrupts are enabled via the Interrupt Mask register. Access to the Interrupt Mask register is gained via the Command Mode and the interrupt source identification is obtained via the Status Mode. Details of these modes are described in the Programming section of this specification.

The RESET# input signal is used to perform a complete asynchronous reset of the XM/DT IC. The RESET# signal is also used to place the XM/DT IC into Command Mode. Refer to the Programming section.

SAII – Synchronous Audio Input Interface

The SAI Interface functional block provides a synchronous interface with hardware flow control from the Master to the Slave devices.

In Master mode, the XM/DT IC receives SAI Data and SAI Clock from the SAI source in the "playback unit". The SAI Enable (SAI_EN) output signal is fed back to the SAI source to control the flow of input data based on the state of the SAI_EN signal at the Slave Device.

In Slave mode, the XM/DT IC sends SAI Data and SAI Clock to the Slave device SAI receiver, and receives the SAI_EN signal from the SAI receiver to control the flow of transmitted data.

The Master XM/DT IC adapts to the incoming SAI data rate.

LSDP – Low Speed Data Port

The LSDP functional block consists of a unidirectional asynchronous serial interface.

In Master mode, the LSDP transmits data out of the device. In Slave mode, the LSDP receives data into the device.

This interface operates in default mode at 115200, no parity, 8 data bits, and 1 stop bit.

HSDP – High Speed Data Port Interface

The HSDP Interface functional block provides a synchronous serial interface combined with a framing signal from the Slave XM/DT IC to the Master XM/DT IC.

The source of the HSDP is typically the XM receiver chipset. The HSDP data is typically received by the Host microprocessor. The HSDP signals include a serial data bitstream (HSDP_DA), a synchronous clock (HSDP_CLK), and a framing signal (HSDP_EN). The framing signal can be used as a gating mechanism for the clock or an interrupt source to indicate the beginning and end of the HSDP data burst.

In Slave mode, the HSDP Interface receives HSDP_DA, HSDP_CLK, and HSDP_EN from the HSDP source. In Master mode, the HSDP Interface transmits HSDP_DA, HSDP_CLK, and HSDP_EN.

I2S – Inter-IC Sound (I2S) digital audio Interface

The I2S functional block receives and transmits timing and frame sensitive data. The I2S interface is also referred to as the PCM interface.

In Slave mode, the XM/DT IC I2S Interface receives the I2S digital audio from the XM Receiver chipset. The XM/DT IC automatically adjusts to the incoming I2S data sampling rate.

In Master mode, the XM/DT IC I2S Interface generates all required signals to drive an I2S compatible audio DAC.

COMM2W – Two Wire Communications Interface

The COMM2W functional block enables communications between two XM/DT ICs. The COMM2W is differential Time-Division-Duplex Interface.

3. Physical Description

3.1 Device Pin-out

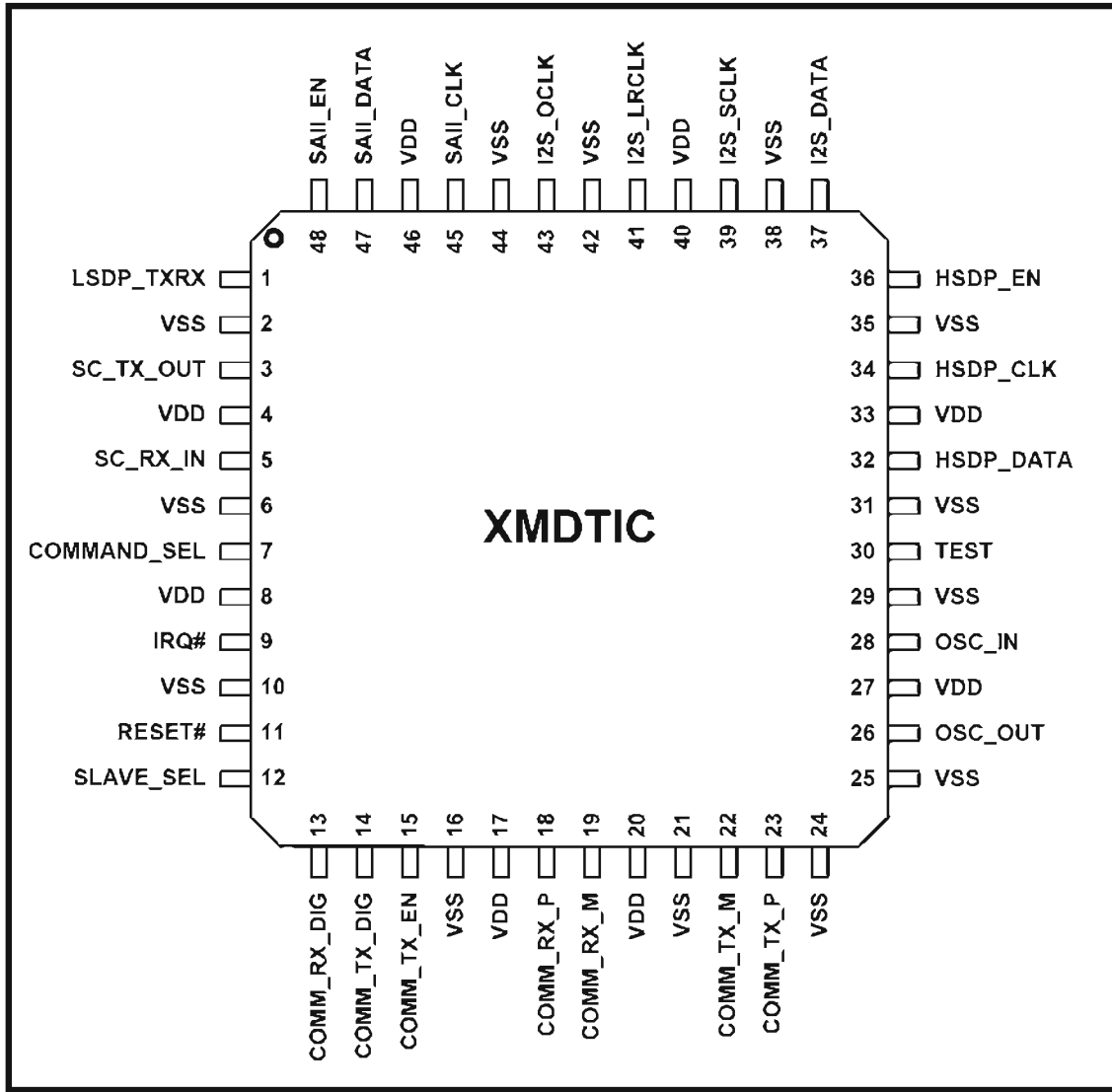

Figure 3.1 – Pin Connection (Top View)

3.2 Pin Descriptions

Table 3.2 Pin Descriptions

Pin #	Pin Name	Type	Function in Slave Mode	Function in Master Mode	Notes
1	LSDP_TXRX	S=In M=Out	Low Speed Data Port Output	Low Speed Data Port Input	LVTTTL S/T
3	SC_TX_OUT	S=Out M=Out	System Controller Bus (CBM) Transmit Data Out	System Controller Bus (CBM) Transmit Data Out	4mA, SLC
5	SC_RX_IN	S=In M=In	System Controller Bus (CBM) Receive Data In	System Controller Bus (CBM) Receive Data In	LVTTTL S/T
7	COMMAND_SEL	S=In M=In	Command Mode Select In (1=Command Mode, 0=Normal Mode)	Command Mode Select In (1=Command Mode, 0=Normal Mode)	LVTTTL S/T
9	IRQ#	S=Out M=Out	Interrupt Request Out (Active Low)	Interrupt Request Out (Active Low)	4mA Open Drain
11	RESET#	S=In M=In	Asynchronous Reset In, (Active Low)	Asynchronous Reset In, (Active Low)	LVTTTL S/T
12	SLAVE_SEL	S=In M=In	M/S Mode Select In (High = Slave Mode)	M/S Mode Select In (Low = Master Mode)	LVTTTL S/T
13	COMM_RX_DIG	S=In M=In	DT Comm Bus External Transceiver Receive Data In	DT Comm Bus External Transceiver Receive Data In	LVTTTL S/T
14	COMM_TX_DIG	Output	DT Comm Bus External Transceiver Transmit Data Out	DT Comm Bus External Transceiver Transmit Data Out	LVTTTL S/T
15	COMM_TX_EN	Output	DT Comm Bus External Transceiver Direction Out (1=Transmit, 0=Receive)	DT Comm Bus External Transceiver Direction Out (1=Transmit, 0=Receive)	LVTTTL S/T
18	COMM_RX_P	S=In M=In	DT Comm Bus Internal Receiver Differential Positive In	DT Comm Bus Internal Receiver Differential Positive In	LVDS in+
19	COMM_RX_M	S=In M=In	DT Comm Bus Internal Receiver Differential Negative In	DT Comm Bus Internal Receiver Differential Negative In	LVDS in-
22	COMM_TX_M	Output	DT Comm Bus Internal Transmitter Differential Negative Out	DT Comm Bus Internal Transmitter Differential Negative Out	LVDS out-
23	COMM_TX_P	Output	DT Comm Bus Internal Transmitter Differential Positive Out	DT Comm Bus Internal Transmitter Differential Positive Out	LVDS out+
26	OSC_OUT	Output	Crystal Output	Crystal Output	Crystal Buffer
28	OSC_IN	S=In M=In	Crystal Input	Crystal Input	Crystal Buffer
30	TEST	S=In M=In	Factory Test Mode Select (1=Test, 0= Normal Oper.)	Factory Test Mode Select (1=Test, 0= Normal Oper.)	LVTTTL S/T
32	HSDP_DATA	S=In M=Out	High Speed Data Port Data Input	High Speed Data Port Data Output	Out= 4mA, SLC In=LVTTTL S/T
34	HSDP_CLK	S=In M=Out	High Speed Data Port Clock Input	High Speed Data Port Clock Output	Out= 4mA, SLC In=LVTTTL S/T
36	HSDP_EN	S=Out M=In	High Speed Data Port Enable Output	High Speed Data Port Enable Input	Out= 4mA, SLC In=LVTTTL S/T
37	I2S_DATA	S=In M=Out	I2S Digital Port Data In	I2S Digital Audio Port Data Out	Out= 4mA, SLC In=LVTTTL S/T

Pin #	Pin Name	Type	Function in Slave Mode	Function in Master Mode	Notes
39	I2S_SCLK	S=In M=Out	I2S Digital Audio Port Bit Clock In	I2S Digital Audio Port Bit Clock Out	Out= 4mA, SLC In=LVTTL S/T
41	I2S_LRCLK	S=In M=Out	I2S Digital Audio Port Left/Right Clock In	I2S Digital Audio Port Left/Right Clock Out	Out= 4mA, SLC In=LVTTL S/T
43	I2S_OCLK	S=In M=Out	I2S Digital Audio Port Oversample Clock (not used - connect to Gnd???)	I2S Digital Audio Port Oversample Clock Out	Out= 4mA, SLC
45	SAII_CLK	S=Out M=In	SAII Port Clock Output	SAII Port Clock Input	Out= 4mA, SLC 3.3V S/T
47	SAII_DATA	S=Out M=In	SAII Port Data Output	SAII Port Data Input	Out= 4mA, SLC In=LVTTL S/T
48	SAII_REQ	S=In M=Out	SAII Port Request Input	SAII Port Request Output	Out= 4mA, SLC In=LVTTL S/T

Pin#	Pin Name	Type	Function in Slave Mode	Function in Master Mode	Notes
4, 8, 17, 20, 27, 33, 40, 46	VDD	PWR	+3.3V Supply Voltage	+3.3V Supply Voltage	
2, 6, 10, 16, 21, 24, 25, 29, 31, 25, 38, 42, 44	VSS	GND	Digital Ground	Digital Ground	

Notes: All Inputs are 3.3V LVTTL compatible; S/T = Schmitt Trigger inputs; SLC = Slew Rate Controller Output



NJM2566A

6CH VIDEO AMPLIFIER WITH SD/ HD LPF

■ GENERAL DESCRIPTION

The NJM2566A is a single supply voltage 6ch Video amplifier. It includes LPF, Y/C MIX circuit and SDC interface. LPF for the component signal can select SD/HD.

The NJM2566A is suitable for DVD recorder, set top box and the high quality AV systems with the SD/HD output.

■ PACKAGE OUTLINE

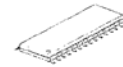

NJM2566AV

■ FEATURES

- Operating Voltage 4.5 to 5.5V
- 6dB amplifier
- Internal 75Ω Driver Circuit (2-system drive)
- Internal LPF V,SY,SC 6.75MHz
Y,Pb,Pr 13.5MHz (Progressive)
30MHz (HD)
- Y/C MIX Circuit
- SDC Interface (S1/ S2)
- CLAMP/ BIAS Select (Y,Pb,Pr/ RGB)
- Power Save Circuit
- Bipolar Technology
- Package Outline SSOP32

■ BLOCK DIAGRAM

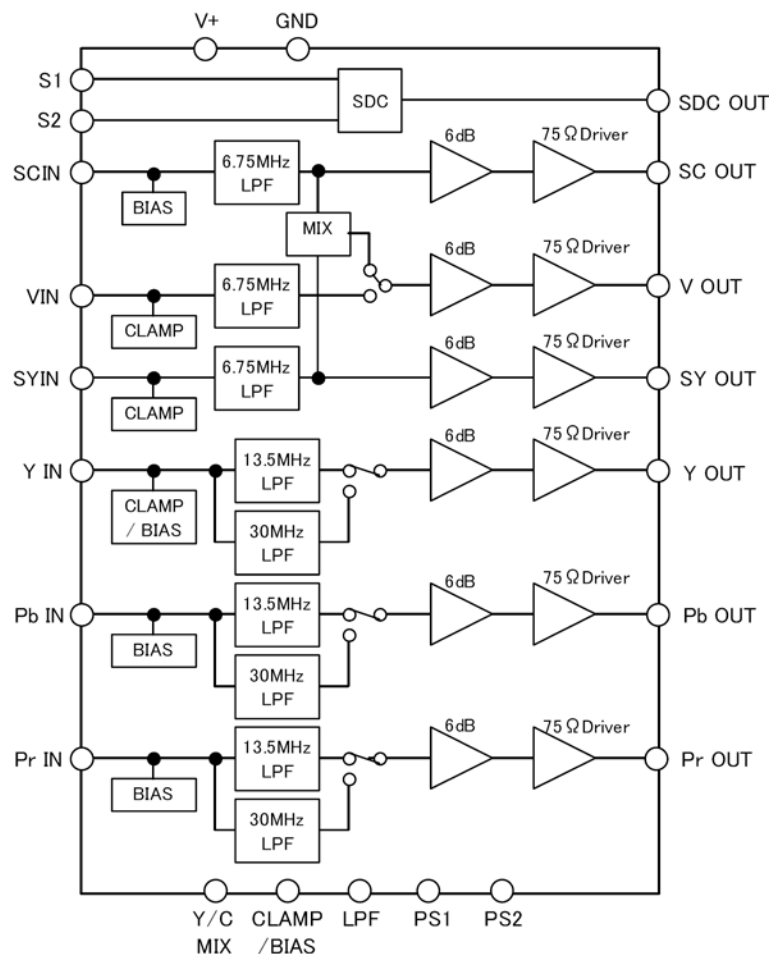



NJM2566A

■ CONTROL TERMINAL

PARAMETER	STATUS	NOTE
PS1 (Power Save1)	H	(SYOUT, VOUT, SCOUT) Power Save: OFF
	L	(SYOUT, VOUT, SCOUT) Power Save: ON
	OPEN	(SYOUT, VOUT, SCOUT) Power Save: ON
PS2 (Power Save2)	H	(YOUT, PbOUT, PrOUT) Power Save: OFF
	L	(YOUT, PbOUT, PrOUT) Power Save: ON
	OPEN	(YOUT, PbOUT, PrOUT) Power Save: ON
MIX SW (Y/C MIX)	H	M/C MIX ON
	L	M/C MIX OFF
	OPEN	M/C MIX OFF
C/B SW (CLAMP/BIAS)	H	BIAS (RGB)
	L	CLAMP (Y,Pb,Pr)
	OPEN	CLAMP (Y,Pb,Pr)
LPF SW (LPF)	H	30MHz LPF
	L	13.5MHz LPF
	OPEN	13.5MHz LPF

■ SDC OUT

S1	S2	SDC OUT	
L (OPEN)	L (OPEN)	0V	4:3 Normal
L (OPEN)	H	2.1V	4:3 Letter box
H	H	2.1V	4:3 Letter box
H	L (OPEN)	4.6V	16:9 Squeeze

■ PIN CONFIGURATION

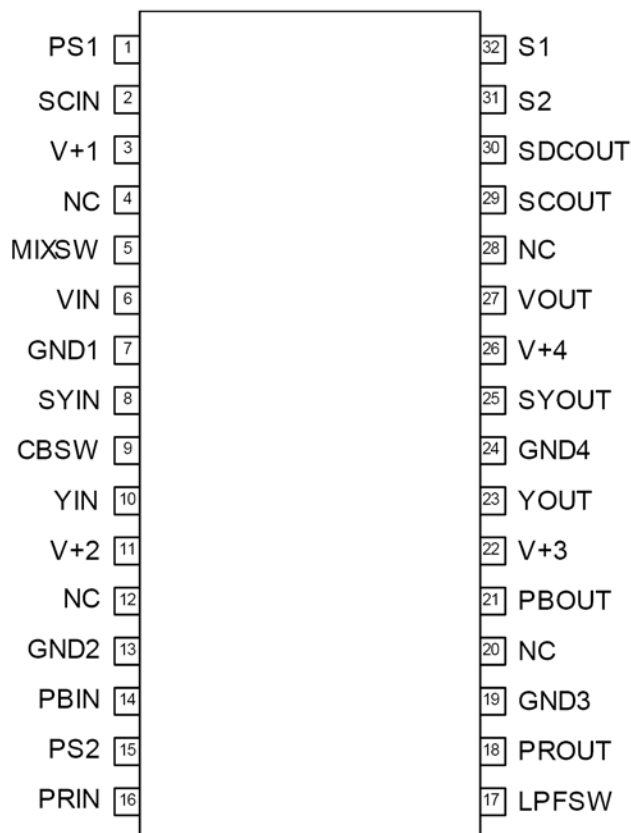



NJM2566A

■ TERMINAL FUNCTION

PIN No.	PIN NAME	FUNCTION	EQUIVALENT CIRCUIT	DC VOLTAGE
1	PS1	(SY, V, SC, SDC) Power save		-
5	MIXSW	Y/C MIX control		
9	CBSW	CLAMP/ BIAS control		
15	PS2	(Y, Pb, Pr) Power save		
17	LPFSW	(Y, Pb, Pr) LPF control		
31	S2	SDC control		
32	S1	SDC control		
2	SCIN	Chroma signal input		2.5V
14	PBIN	Component signal(Pb), R input		
16	PRIN	Component signal(Pr), B input		
6	VIN	Composite video signal input		1.7V
8	SYIN	Y signal input		
10	YIN	Component signal(Y), G input (Note) Y signal: CLAMP G signal: BIAS		(CLAMP) 1.7V (BIAS) 2.5V



NJM2566A

PIN No.	PIN NAME	FUNCTION	EQUIVALENT CIRCUIT	DC VOLTAGE
18 21 29	PROUT PBOUT SCOUT	Component signal(Cr) output Component signal(Cb) output Chroma signal output		2.5V
23 25 27	YOUT SYOUT VOUT	Component signal(Y) output Y signal output Composite video signal output		1.3V (Note) YOUT BIAS: 2.5V
30	SDCOUT	SDC output		-



NJW1321

WIDE BAND VIDEO SWITCH WITH I²C BUS

■ GENERAL DESCRIPTION

The NJW1321 is a Wide Band Video Switch with I²C BUS.

The NJW1321 includes switch of 4-input 2-output and 6dB amplifier. It is suitable for RGB or Y, Pb, and Pr signal because frequency range is 100MHz.

The NJW1321 includes external logic control terminals and external logic discernment terminals.

The NJW1321 is suitable for PTV, DTV, PDP and other high quality AV systems.

■ PACKAGE OUTLINE



NJW1321FP1

■ FEATURES

- Operating Voltage +9.0V
- I²C BUS Interface
- 4-input 2-output 3-Circuits
- Wide frequency range 0dB at 100MHz typ.
-3dB at 300MHz typ.
- Internal 6dB amplifier (Selectable Bypass or 6dB)
- External logic discernment terminal
- External logic control terminal
- Selectable slave address
- Power Save Circuit
- Bi-CMOS Technology
- Package Outline QFP48

■ BLOCK DIAGRAM

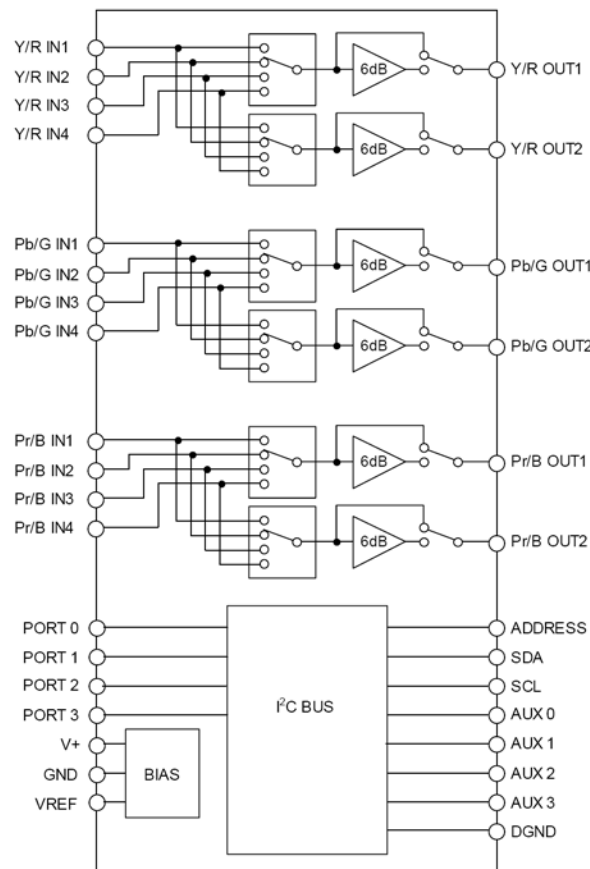

NJW1321

PIN CONFIGURATION

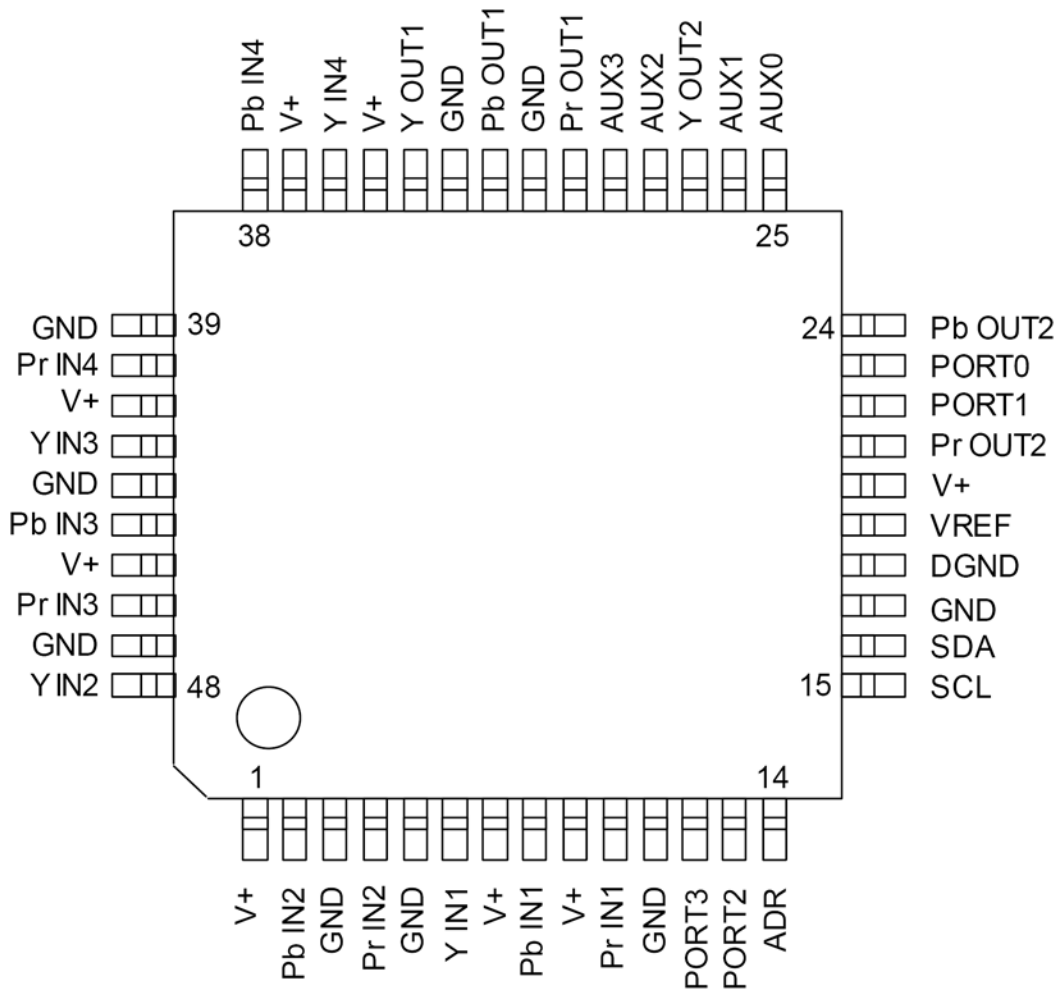

1. V+	13. PORT2	25. AUX0	37. V+
2. Pb IN2	14. ADR	26. AUX1	38. Pb IN4
3. GND	15. SCL	27. Y OUT2	39. GND
4. Pr IN2	16. SDA	28. AUX2	40. Pr IN4
5. GND	17. GND	29. AUX3	41. V+
6. Y IN1	18. DGND	30. Pr OUT1	42. Y IN3
7. V+	19. VREG	31. GND	43. GND
8. Pb IN1	20. V+	32. Pb OUT1	44. Pb IN3
9. V+	21. Pr OUT2	33. GND	45. V+
10. Pr IN1	22. PORT1	34. Y OUT1	46. Pr IN3
11. GND	23. PORT0	35. V+	47. GND
12. PORT3	24. Pb OUT2	36. Y IN4	48. Y IN2

NJW1321

■EQUIVALENT CIRCUIT

PIN No.	NAME	FUNCTION	INSIDE EQUIVALENT CIRCUIT	VOLTAGE
6 8 10 48 2 4 42 44 46 36 38 40	Y IN1 Pb IN1 Pr IN1 Y IN2 Pb IN2 Pr IN2 Y IN3 Pb IN3 Pr IN3 Y IN4 Pb IN4 Pr IN4	Y,Pb,Pr Input RGB Input		4.4V
34 32 30 27 24 21	Y OUT1 Pb OUT1 Pr OUT1 Y OUT2 Pb OUT2 Pr OUT2	Y,Pb,Pr Output RGB Output		3.7V
23 22 13 12	PORT0 PORT1 PORT2 PORT3	Logic input terminal		-
25 26 28 29	AUX0 AUX1 AUX2 AUX3	Auxiliary 3 values voltage output terminal		0V 1.9V 5.0V

NJW1321

PIN No.	NAME	FUNCTION	INSIDE EQUIVALENT CIRCUIT	VOLTAGE
14	ADR	Slave address setting terminal		-
15 16	SCL SDA	I ² C clock terminal I ² C data terminal		-
19	VREF	Reference voltage terminal		4.8V
1 7 9 20 35 37 41 45	V+	Supply voltage terminal		-
3 5 11 17 31 33 39 43 47	GND	Ground terminal		-
18	DGND	Ground terminal		-

NJW1197FC2 [8-CHANNEL ELECTRONIC VOLUME WITH INPUT SELECTOR]

[STRUCTURE] Bi-CMOS
 [CATEGORIES] 3D Surround & Sound Enhancement
 [PACKAGE OUTLINE] QFP100-C2
 [SOLDERING METHOD] For this device, soldering method is recommended Reflow.
 [NOTE] -

BAE-45919-000-00

ABSOLUTE MAXIMUM RATINGS $T_a=25^{\circ}\text{C}$

Power Supply Voltage +8/-8 [V]	Operating Temperature Range -40 to +75 [°C]
Maximum Input Voltage V^+/V^- [V]	Storage Temperature Range -40 to +150 [°C]
Power Dissipation 1600 [mW] (Note)	

(Note) EIA/JEDEC STANDARD Test board (76.2 × 114.3 × 1.6mm, 2layer, FR-4) mounting.

BLOCK DIAGRAM

BDE-45919-000-00

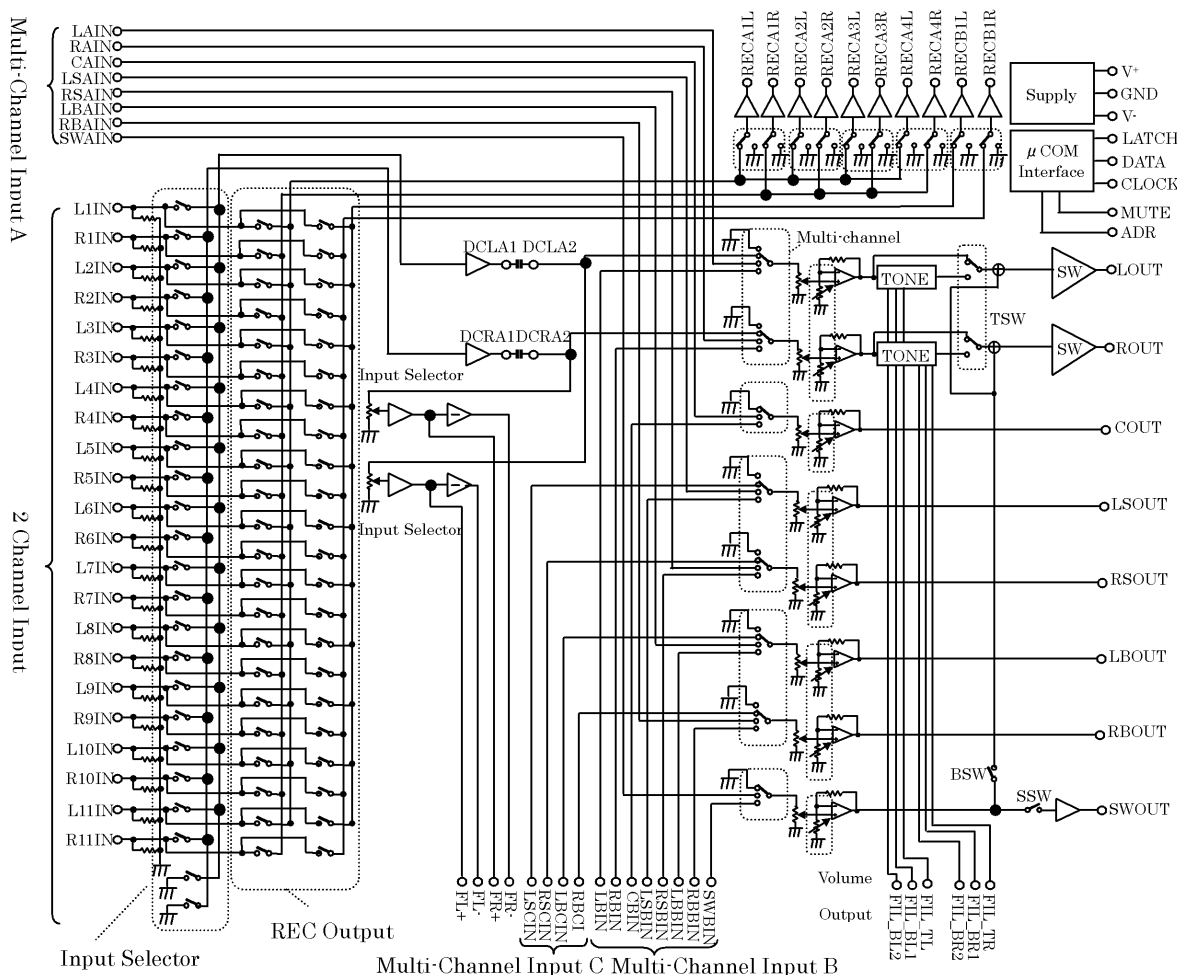

■ PIN CONFIGURAITON

BEE-45919-000-00

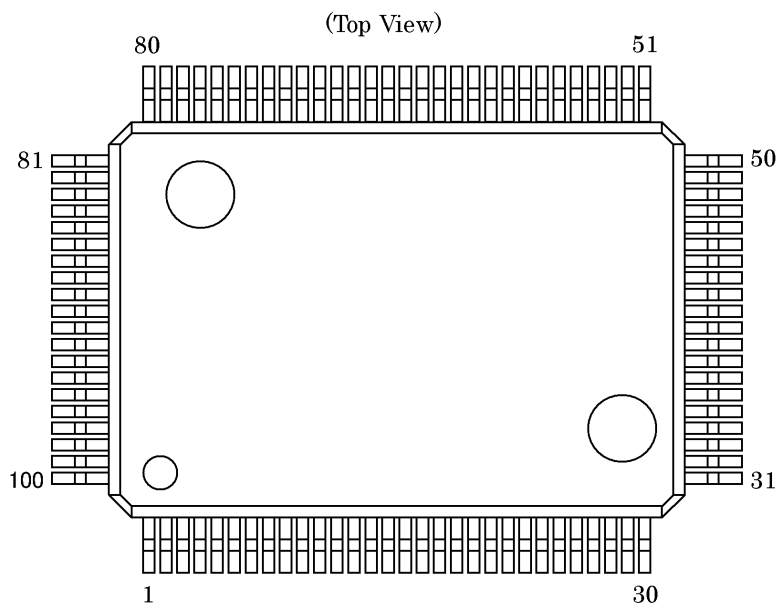

No.	SYMBOL	No.	SYMBOL	No.	SYMBOL	No.	SYMBOL
1	ROUT	26	DCCAP_RS	51	DCR_IN	76	GND
2	COUT	27	L3IN	52	DCR_OUT	77	LSCIN
3	LSOUT	28	DCCAP_LS	53	GND	78	RSCIN
4	RSOUT	29	R3IN	54	DCL_IN	79	LBCIN
5	LBOUT	30	DCCAP_C	55	DCL_OUT	80	RBCIN
6	RBOUT	31	L4IN	56	GND	81	GND
7	SWOUT	32	DCCAP_R	57	REC_B1R	82	LAIN
8	GND	33	R4IN	58	REC_B1L	83	RAIN
9	FIL_BL2	34	DCCAP_L	59	REC_A4R	84	CAIN
10	FIL_BL1	35	L5IN	60	REC_A4L	85	LSAIN
11	FIL_TL	36	GND	61	REC_A3R	86	RSAIN
12	TCAP	37	R5IN	62	REC_A3L	87	LBAIN
13	FIL_BR2	38	GND	63	REC_A2R	88	RBAIN
14	FIL_BR1	39	L6IN	64	REC_A2L	89	SWAIN
15	FIL_TR	40	L9IN	65	REC_A1R	90	GND
16	V+	41	R6IN	66	REC_A1L	91	LBIN
17	ADR	42	R9IN	67	VDDOUT	92	RBIN
18	V-	43	L7IN	68	DATA	93	CBIN
19	L1IN	44	L10IN	69	CLOCK	94	LSBIN
20	DCCAP_SW	45	R7IN	70	LATCH	95	RSBIN
21	R1IN	46	R10IN	71	MUTE	96	LBBIN
22	DCCAP_RB	47	L8IN	72	FL+	97	RBBIN
23	L2IN	48	L11IN	73	FL-	98	SWBIN
24	DCCAP_LB	49	R8IN	74	FR+	99	GND
25	R2IN	50	R11IN	75	FR-	100	LOUT

FUNCTIONAL DESCRIPTION

BGE-45919-000-00

(1) CONTROL DATA

NJW1197 control data is constructed with 16bits.

MSB

LSB

D15	D14	D13	D12	D11	D10	D9	D8	D7	D6	D5	D4	D3	D2	D1	D0
Data								Select Address				Chip Address			

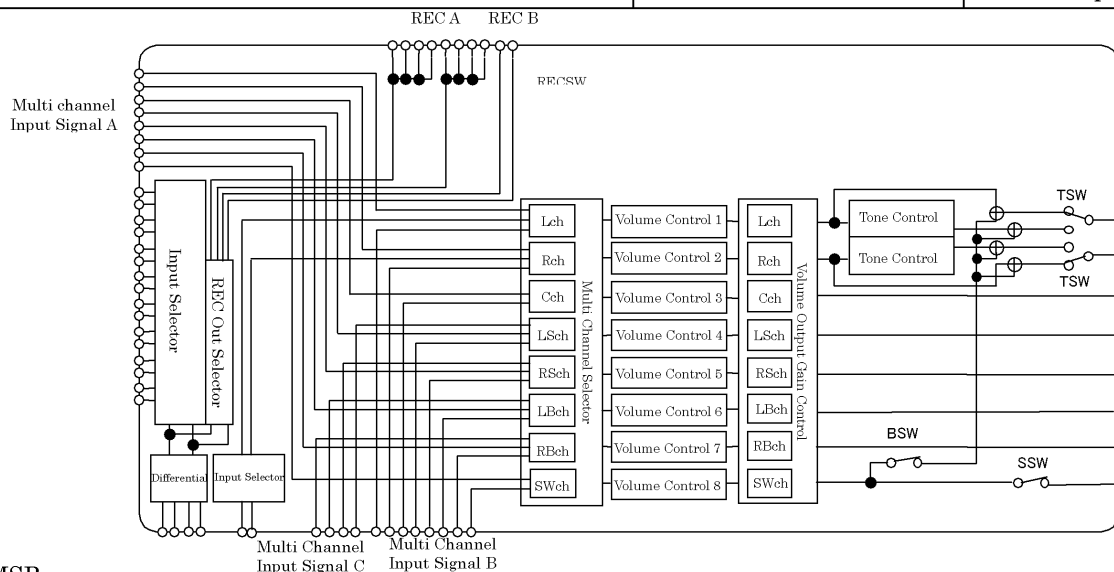

MSB

LSB

D15	D14	D13	D12	D11	D10	D9	D8	D7	D6	D5	D4	D3	D2	D1	D0
L channel Volume Control								0	0	0	0	*	*	*	*
R channel Volume Control								0	0	0	1	*	*	*	*
C channel Volume Control								0	0	1	0	*	*	*	*
LS channel Volume Control								0	0	1	1	*	*	*	*
RS channel Volume Control								0	1	0	0	*	*	*	*
LB channel Volume Control								0	1	0	1	*	*	*	*
RB channel Volume Control								0	1	1	0	*	*	*	*
SW channel Volume Control								0	1	1	1	*	*	*	*
Input Selector Gain Control		Input Selector					SSW	1	0	0	0	*	*	*	*
TC/B	Tone Control Treble				TSW	BSW	*	1	0	0	1	*	*	*	*
BC/B	Tone Control Bass				*	*	*	1	0	1	0	*	*	*	*
REC B Selector				Input Selector				1	0	1	1	*	*	*	*
SWch Volume Output Gain Control		REC B1	REC A4	REC A3	REC A2	REC A1	1	1	0	0	*	*	*	*	
L, Rch Volume Output Gain Control		Cch, Volume Output Gain Control			*	*	1	1	0	1	*	*	*	*	
LS, RSch Volume Output Gain Control		LB, RBch Volume Output Gain Control		SWch Selector		1	1	1	0	*	*	*	*		
L, Rch Selector		Cch Selector		LS, RSch Selector		LB, RBch Selector		1	1	1	1	*	*	*	*

*: Don't Care

* Chip address is set by chip address select terminal (ADR) status.

Chip Address Select Terminal (ADR: 17pin)	Chip Address			
	D3	D2	D1	D0
Low	0	1	0	0
High	0	1	0	1

* The mute function can be controlled externally. If the Mute control terminal (71pin) is switched to High, Multi-Channel outputs are muted immediately (hardware mute).

External mute control terminal (MUTE: 71pin)	Setting
Low	Mute cancellation
High	Mute



ST202E ST232E

± 15KV ESD PROTECTED 5V RS-232 TRANSCEIVER

- ESD PROTECTION FOR RS-232 I/O PINS:
± 15 KV HUMAN BODY MODEL
- GUARANTEED 120 kbps DATA RATE
- GUARANTEED SLEW RATE RANGE 3 to 30V/μs
- OPERATE FROM A SINGLE 5V POWER SUPPLY

DESCRIPTION

The ST202E/ST232E are a 2 driver 2 receiver devices designed for RS-232 and V.28 communications in harsh environments. Each transmitter output and receiver input is protected against ± 15KV electrostatic discharge (ESD) shocks. The drivers meet all EIA/TIA-232E and CCITT V.28 specifications at data rates up to 120Kbps, when loaded in accordance with the EIA/TIA-232E specification.

The ST202E/232E use a single 5V supply voltage.

The ST232E operates with four 1μF capacitors,

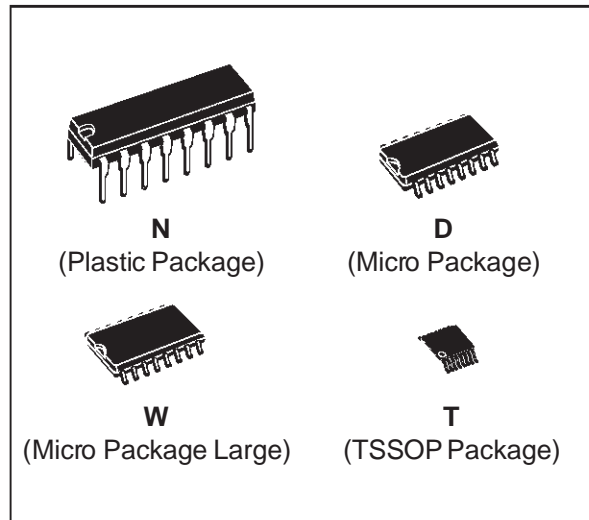

while the ST202E operates with four 0.1μF capacitors, further reducing cost and board space.

ORDER CODES

Type		Temperature Range	Package	Comments
ST202ECN	ST232ECN	0 to 70 °C	DIP-16	25 parts per tube / 40 tube per box
ST202EBN	ST232EBN	-40 to 85 °C	DIP-16	25 parts per tube / 40 tube per box
ST202ECD	ST232ECD	0 to 70 °C	SO-16 (Tube)	50 parts per tube / 20 tube per box
ST202EBD	ST232EBD	-40 to 85 °C	SO-16 (Tube)	50 parts per tube / 20 tube per box
ST202ECDR	ST232ECDR	0 to 70 °C	SO-16 (Tape & Reel)	2500 parts per reel
ST202EBDR	ST232EBDR	-40 to 85 °C	SO-16 (Tape & Reel)	2500 parts per reel
ST202ECW	ST232ECW	0 to 70 °C	SO-16 Large (Tube)	50 parts per tube / 20 tube per box
ST202EBW	ST232EBW	-40 to 85 °C	SO-16 Large (Tube)	50 parts per tube / 20 tube per box
ST202ECWR	ST232ECWR	0 to 70 °C	SO-16 Large (Tape & Reel)	1000 parts per reel
ST202EBWR	ST232EBWR	-40 to 85 °C	SO-16 Large (Tape & Reel)	1000 parts per reel
ST202ECTR	ST232ECTR	0 to 70 °C	TSSOP16 (Tape & Reel)	2500 parts per reel
ST202EBTR	ST232EBTR	-40 to 85 °C	TSSOP16 (Tape & Reel)	2500 parts per reel

ST202E/ST232E

PIN CONFIGURATION

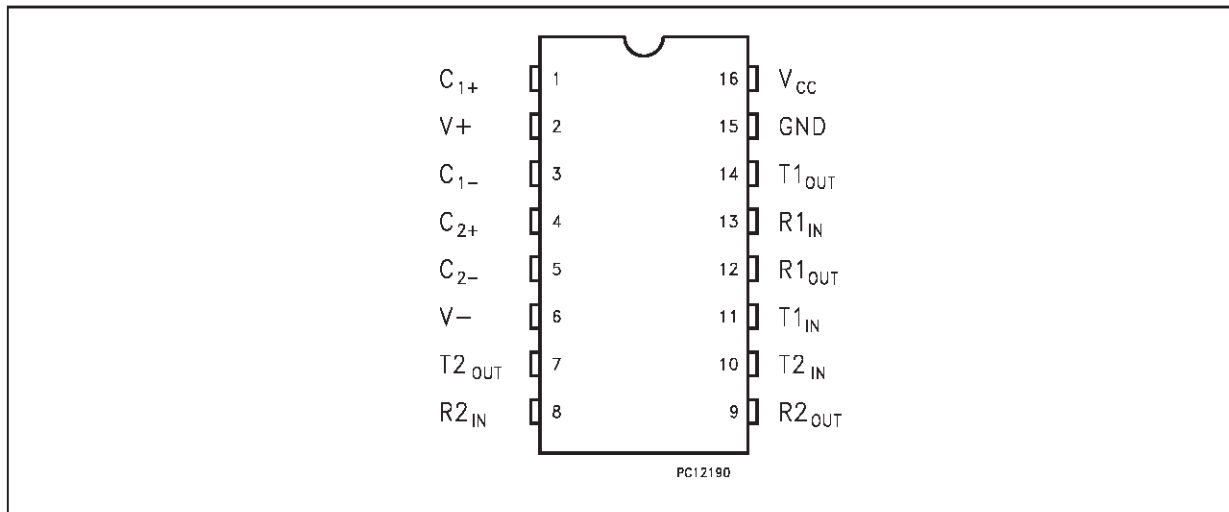

PIN DESCRIPTION

PIN No	SYMBOL	NAME AND FUNCTION
1	C ₁₊	Positive Terminal for the first Charge Pump Capacitor
2	V+	Doubled Voltage Terminal
3	C ₁₋	Negative Terminal for the first Charge Pump Capacitor
4	C ₂₊	Positive Terminal for the second Charge Pump Capacitor
5	C ₂₋	Negative Terminal for the second Charge Pump Capacitor
6	V-	Inverted Voltage Terminal
7	T ₂ OUT	Second Transmitter Output Voltage
8	R ₂ IN	Second Receiver Input Voltage
9	R ₂ OUT	Second Receiver Output Voltage
10	T ₂ IN	Second Transmitter Input Voltage
11	T ₁ IN	First Transmitter Input Voltage
12	R ₁ OUT	First Receiver Output Voltage
13	R ₁ IN	First Receiver Input Voltage
14	T ₁ OUT	First Transmitter Output Voltage
15	GND	Ground
16	V _{CC}	Supply Voltage



NJU7301

C-MOS QUAD SPST ANALOG SWITCH

■ GENERAL DESCRIPTION

The NJU7301 is a quad break-before-make SPST analog switch protected up to 44V operating voltage.

Each switch is controlled by TTL or C-MOS compatible input.

■ PACKAGE OUTLINE

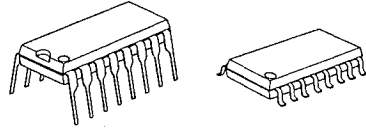

NJU7301D

NJU7301M

■ FEATURES

- High Break Down Voltage -- 44V
- Package Outline -- DIP/DMP 16
- C-MOS Technology

■ PIN CONFIGURATION

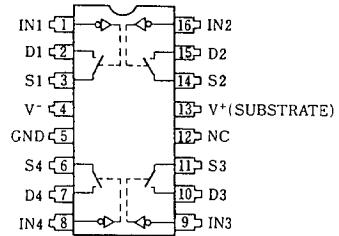

6

■ TRUTH TABLE

Logic (In)	Switch
0	ON
1	OFF

■ EQUIVALENT CIRCUIT

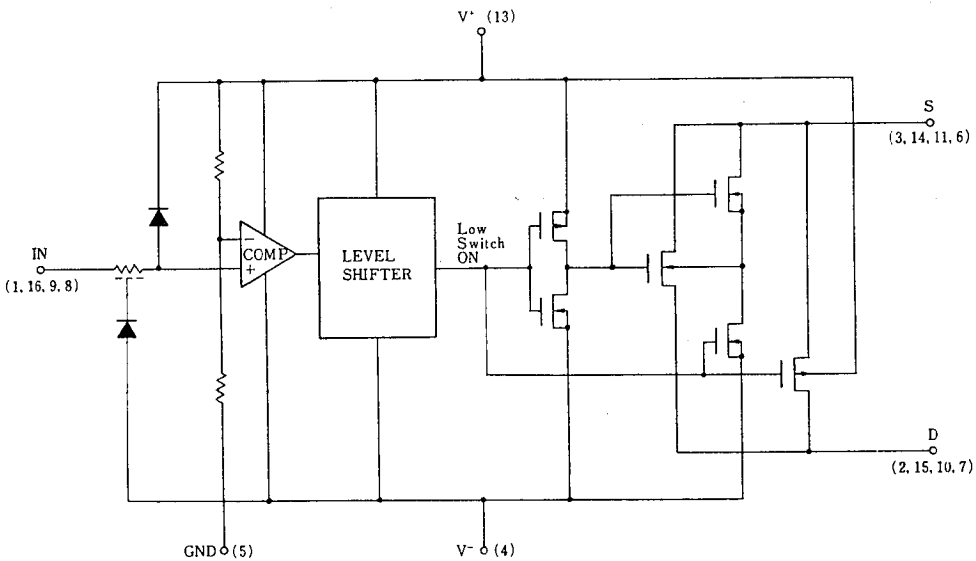

* Logic input threshold voltage V_{TH} is about $V^+ \times 0.128(V)$.
When the designing, enough margin is required.



NJM2137

ULTRA WIDE BAND, HIGH SLEW RATE DUAL OPERATIONAL AMPLIFIER

■ GENERAL DESCRIPTION

The NJM2137 is an ultra wide band, high slew rate dual operational amplifier operated from low voltage ($\pm 1.35V$).

It can apply to active filter, high speed analog and digital signal processor, line driver, HDTV, industrial measurement equipment and others.

It can also apply to portable communication items because of low operating voltage and low operating current.

■ PACKAGE OUTLINE



NJM2137V



NJM2137M

■ FEATURES

- Operating Voltage ($\pm 1.35V \sim \pm 6V$)
- Ultra Wide Band (200MHz typ.)
- High Slew Rate ($45V/\mu s$ typ.)
- Low Operating Current (1.14mA typ.)
- Bipolar Technology
- Package Outline SSOP8, DMP8

■ PIN CONFIGURATION

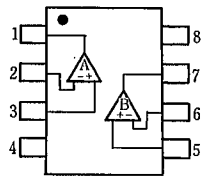

NJM2137M
NJM2137V

PIN FUNCTION

1. A OUTPUT
2. A -INPUT
3. A +INPUT
4. V⁻
5. B +INPUT
6. B -INPUT
7. B OUTPUT
8. V⁺

■ EQUIVALENT CIRCUIT (1/2 Shown)

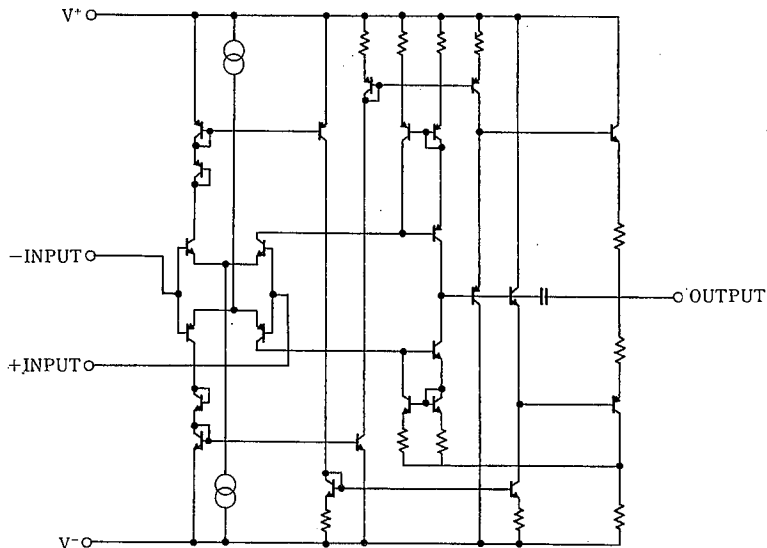

4



M24C64

M24C32

64Kbit and 32Kbit Serial I²C Bus EEPROM

FEATURES SUMMARY

- Two-Wire I²C Serial Interface
Supports 400kHz Protocol
- Single Supply Voltage:
 - 4.5 to 5.5V for M24Cxx
 - 2.5 to 5.5V for M24Cxx-W
 - 1.8 to 5.5V for M24Cxx-R
- Write Control Input
- BYTE and PAGE WRITE (up to 32 Bytes)
- RANDOM and SEQUENTIAL READ Modes
- Self-Timed Programming Cycle
- Automatic Address Incrementing
- Enhanced ESD/Latch-Up Protection
- More than 1 Million Erase/Write Cycles
- More than 40-Year Data Retention

Table 1. Product List

Reference	Part Number
M24C64	M24C64
	M24C64-W
	M24C64-R
M24C32	M24C32
	M24C32-W
	M24C32-R

Figure 1. Packages

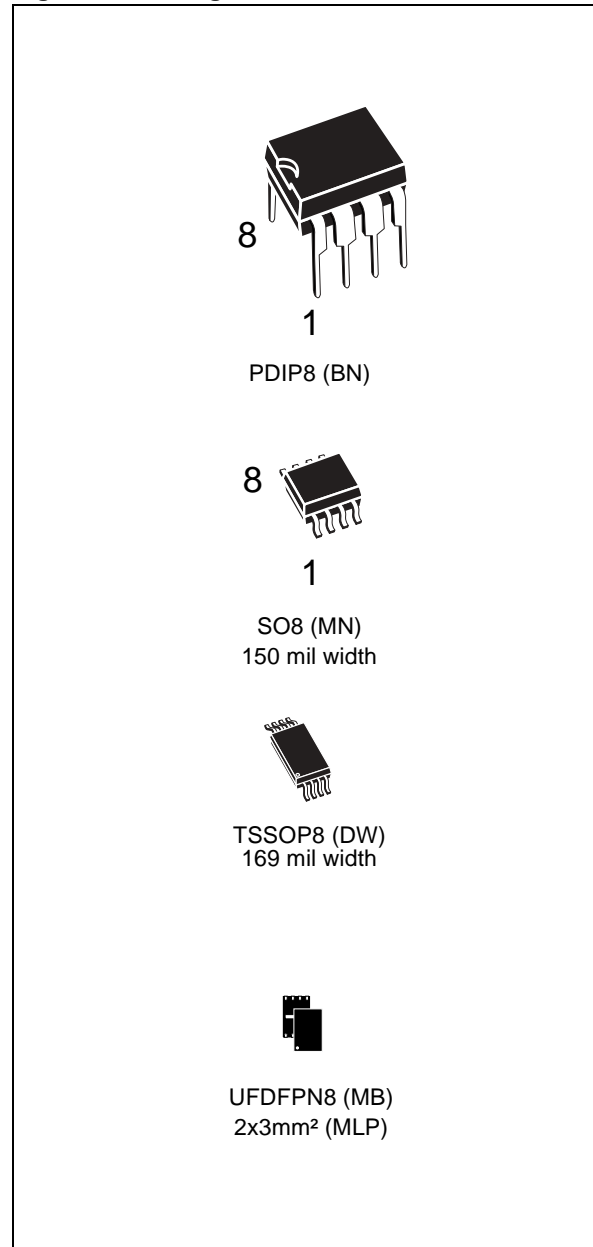

M24C64, M24C32

SUMMARY DESCRIPTION

These I²C-compatible electrically erasable programmable memory (EEPROM) devices are organized as 8192 x 8 bits (M24C64) and 4096 x 8 bits (M24C32).

Figure 2. Logic Diagram

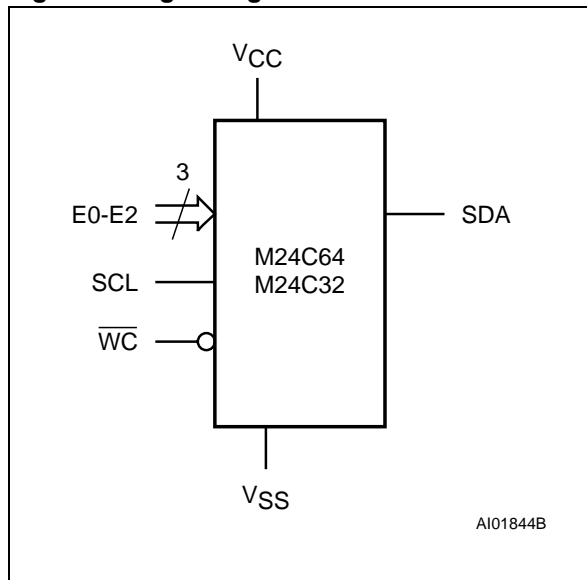

I²C uses a two-wire serial interface, comprising a bi-directional data line and a clock line. The devices carry a built-in 4-bit Device Type Identifier code (1010) in accordance with the I²C bus definition.

The device behaves as a slave in the I²C protocol, with all memory operations synchronized by the serial clock. Read and Write operations are initiated by a Start condition, generated by the bus master. The Start condition is followed by a Device Select Code and Read/Write bit (RW) (as described in Table 3.), terminated by an acknowledge bit.

When writing data to the memory, the device inserts an acknowledge bit during the 9th bit time, following the bus master's 8-bit transmission. When data is read by the bus master, the bus master acknowledges the receipt of the data byte in the same way. Data transfers are terminated by a Stop condition after an Ack for Write, and after a NoAck for Read.

Table 2. Signal Names

E0, E1, E2	Chip Enable
SDA	Serial Data
SCL	Serial Clock
\overline{WC}	Write Control
VCC	Supply Voltage
VSS	Ground

Power On Reset: V_{CC} Lock-Out Write Protect

In order to prevent data corruption and inadvertent Write operations during Power-up, a Power On Reset (POR) circuit is included. At Power-up, the internal reset is held active until V_{CC} has reached the Power On Reset (POR) threshold voltage, and all operations are disabled – the device will not respond to any command. In the same way, when V_{CC} drops from the operating voltage, below the Power On Reset (POR) threshold voltage, all operations are disabled and the device will not respond to any command.

A stable and valid V_{CC} (as defined in Table 9. and Table 10.) must be applied before applying any logic signal.

Figure 3. DIP, SO, TSSOP and UDFPN Connections

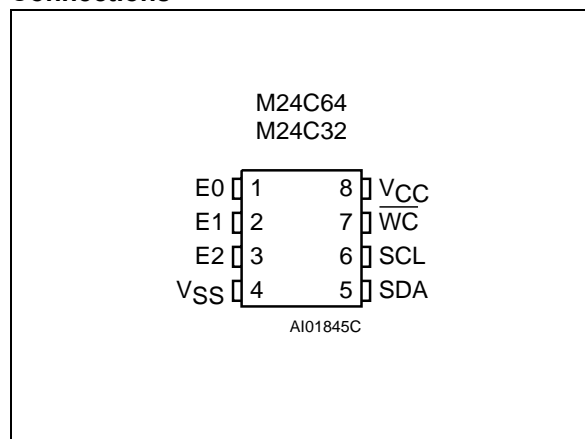

Note: See [PACKAGE MECHANICAL](#) section for package dimensions, and how to identify pin-1.

TOSHIBA

TC7MZ4051,4052,4053FK

TOSHIBA CMOS Digital Integrated Circuit Silicon Monolithic

TC7MZ4051FK,TC7MZ4052FK,TC7MZ4053FK

TC7MZ4051FK 8-Channel Analog Multiplexer/Demultiplexer

TC7MZ4052FK Dual 4-Channel Analog Multiplexer/Demultiplexer

TC7MZ4053FK Triple 2-Channel Analog Multiplexer/Demultiplexer

The TC7MZ4051/4052/4053FK are high-speed, low-voltage drive analog multiplexer/demultiplexers using silicon gate CMOS technology. In 3 V and 5 V systems these can achieve high-speed operation with the low power dissipation that is a feature of CMOS.

The TC7MZ4051/4052/4053FK offer analog/digital signal selection as well as mixed signals. The 4051 has an 8-channel configuration, the 4052 has an 4-channel \times 2 configuration, and the 4053 has a 2-channel \times 3 configuration.

The switches for each channel are turned ON by the control pin digital signals.

Although the control signal logical amplitude ($V_{CC} - GND$) is small, the device can perform large-amplitude ($V_{CC} - V_{EE}$) signal switching.

For example, if $V_{CC} = 3\text{ V}$, $GND = 0\text{ V}$, and $V_{EE} = -3\text{ V}$, signals between -3 V and $+3\text{ V}$ can be switched from the logical circuit using a single 3 V power supply.

All input pins are equipped with a newly developed input protection circuit that avoids the need for a diode on the plus side (forward side from the input to the V_{CC}). As a result, for example, 5 V signals can be permitted on the inputs even when the power supply voltage to the circuits is off. As a result of this input power protection, the TC7MZ4051/4052/4053FK can be used in a variety of applications, including in the system which has two power supplies, and in battery backup circuits.

Features

- Low ON resistance: $R_{on} = 22\ \Omega$ (typ.) ($V_{CC} - V_{EE} = 3\text{ V}$)
 $R_{on} = 15\ \Omega$ (typ.) ($V_{CC} - V_{EE} = 6\text{ V}$)
- High speed: $t_{pd} = 3\text{ ns}$ (typ.) ($V_{CC} = 3.0\text{ V}$)
- Low power dissipation: $I_{CC} = 4\ \mu\text{A}$ (max) ($T_a = 25^\circ\text{C}$)
- Input level: $V_{IL} = 0.8\text{ V}$ (max) ($V_{CC} = 3\text{ V}$)
 $V_{IH} = 2.0\text{ V}$ (min) ($V_{CC} = 3\text{ V}$)
- Power down protection is provided on all control inputs
- Pin and function compatible with 74HC4051/4052/4053

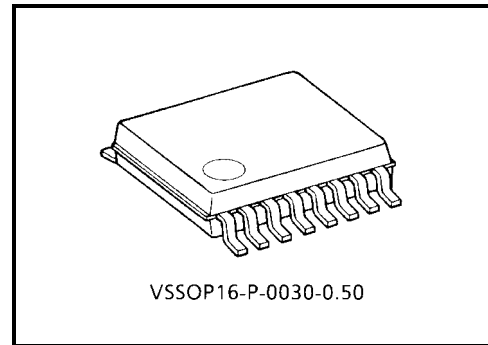

Weight: 0.02 g (typ.)

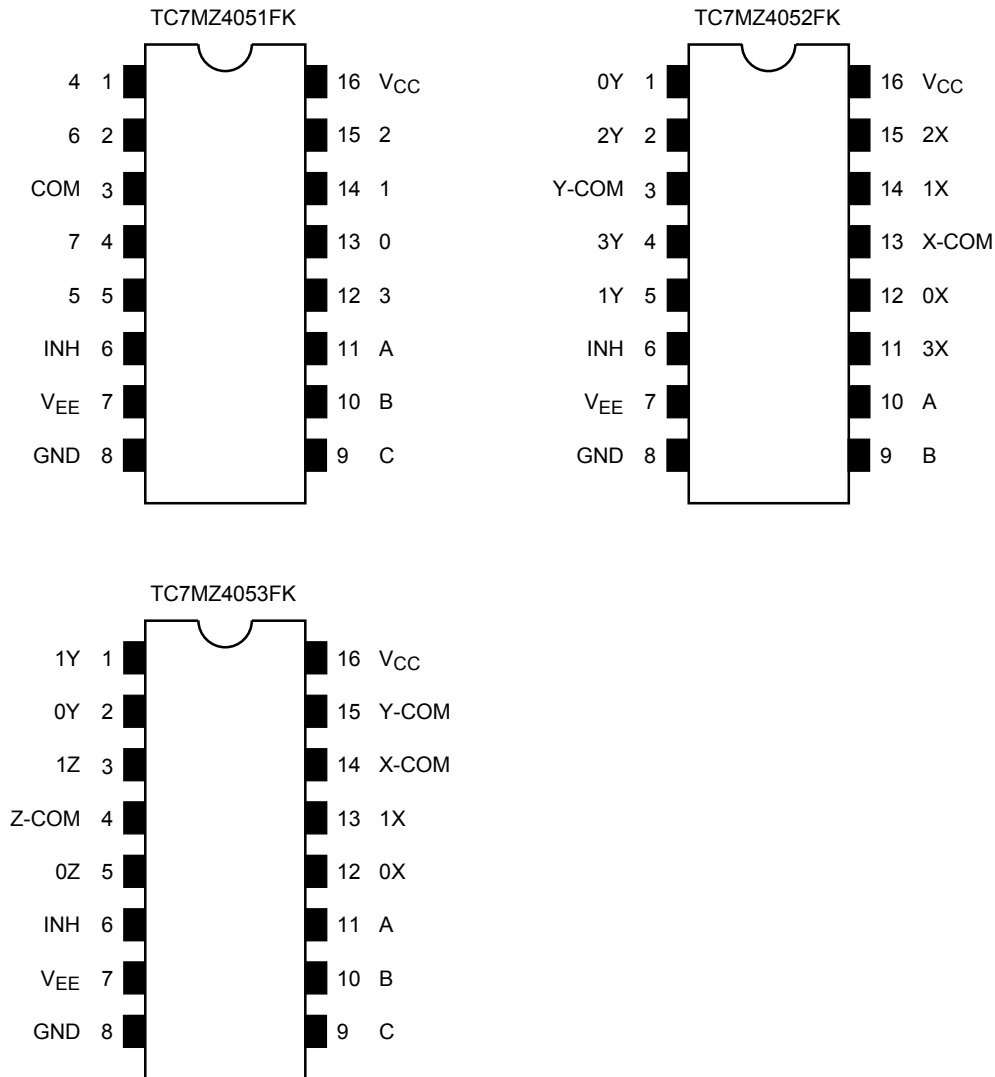
TOSHIBA**TC7MZ4051,4052,4053FK****Pin Assignment (top view)****Truth Table**

Control Inputs				"ON" Channel		
Inhibit	C*	B	A	MZ4051FK	MZ4052FK	MZ4053FK
L	L	L	L	0	0X, 0Y	0X, 0Y, 0Z
L	L	L	H	1	1X, 1Y	1X, 0Y, 0Z
L	L	H	L	2	2X, 2Y	0X, 1Y, 0Z
L	L	H	H	3	3X, 3Y	1X, 1Y, 0Z
L	H	L	L	4	—	0X, 0Y, 1Z
L	H	L	H	5	—	1X, 0Y, 1Z
L	H	H	L	6	—	0X, 1Y, 1Z
L	H	H	H	7	—	1X, 1Y, 1Z
H	X	X	X	None	None	None

X: Don't care, *: Except MZ4052FK

TOSHIBA

TC7MZ4051,4052,4053FK

System Diagram

TC7MZ4051FK

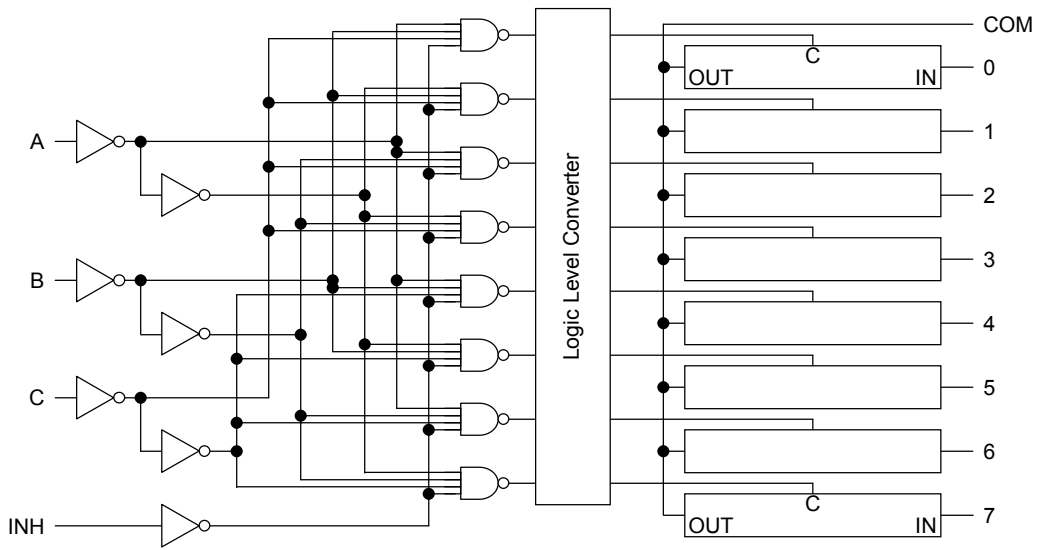

TC7MZ4052FK

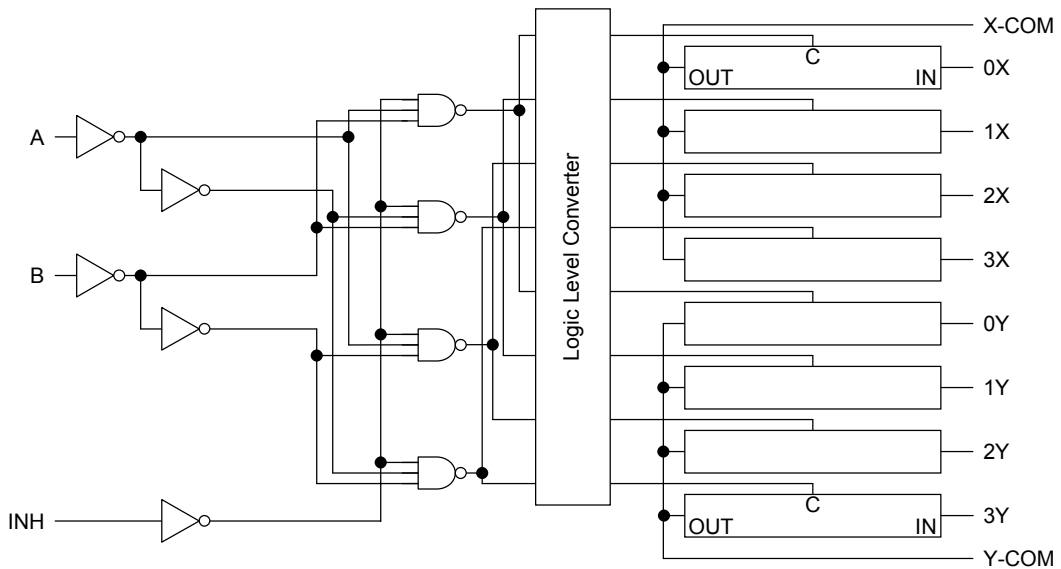

TC7MZ4053FK

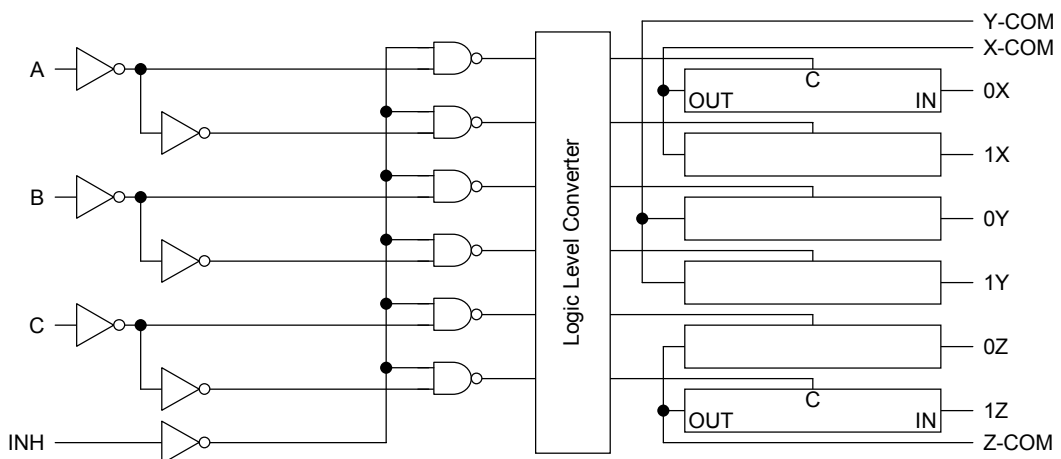



QUICKSWITCH® PRODUCTS
2.5V / 3.3V 32:16 MUX/DEMUX
HIGH BANDWIDTH BUS SWITCH

IDTQS3VH16233

FEATURES:

- N channel FET switches with no parasitic diode to Vcc
 - Isolation under power-off conditions
 - No DC path to Vcc or GND
 - 5V tolerant in OFF and ON state
- 5V tolerant I/Os
- Low RON - 4Ω typical
- Flat RON characteristics over operating range
- Rail-to-rail switching 0 - 5V
- Bidirectional dataflow with near-zero delay: no added ground bounce
- Excellent RON matching between channels
- Vcc operation: 2.3V to 3.6V
- High bandwidth - up to 500 MHz
- LVTTTL-compatible control Inputs
- Undershoot Clamp Diodes on all switch and control Inputs
- Low I/O capacitance, 4pF typical
- Available in SSOP and TSSOP packages

APPLICATIONS:

- Hot-swapping
- 10/100 Base-T, Ethernet LAN switch
- Low distortion analog switch
- Replaces mechanical relay
- ATM 25/155 switching

DESCRIPTION:

The QS3VH16233 HotSwitch is a 32-bit to 16-bit high bandwidth bus switch, which can multiplex or demultiplex data. The QS3VH16233 has very low ON resistance, resulting in under 250ps propagation delay through the switch. This device can be used as two 16-bit to 8-bit multiplexers or as one 32-bit to 16-bit multiplexer. SELx inputs control the data flow. TESTx inputs control either one or two ports connection. In the OFF and ON states, the switches are 5V-tolerant. In the OFF state, the switches offer very high impedance at the terminals.

The combination of near-zero propagation delay, high OFF impedance, and over-voltage tolerance also makes the QS3VH16233 ideal for high performance communications applications.

The QS3VH16233 is characterized for operation from -40°C to +85°C.

FUNCTIONAL BLOCK DIAGRAM

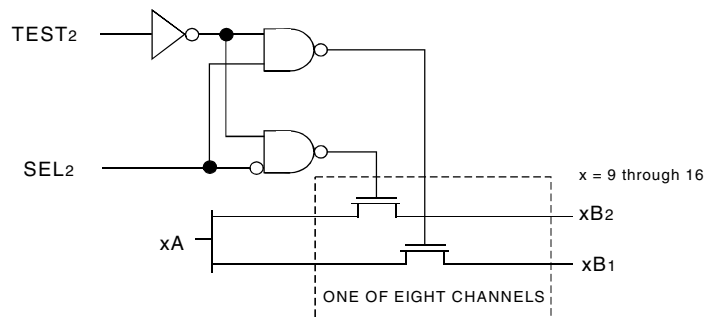
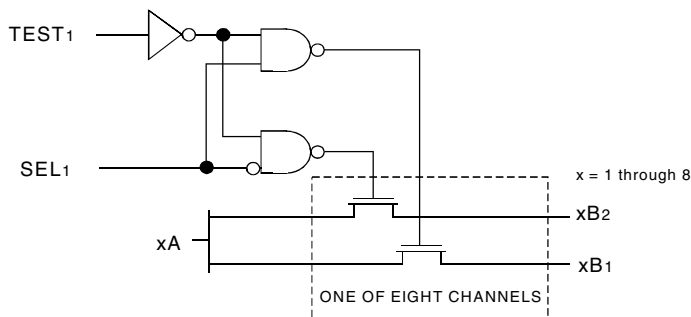

The IDT logo is a registered trademark of Integrated Device Technology, Inc.

INDUSTRIAL TEMPERATURE RANGE

PIN CONFIGURATION

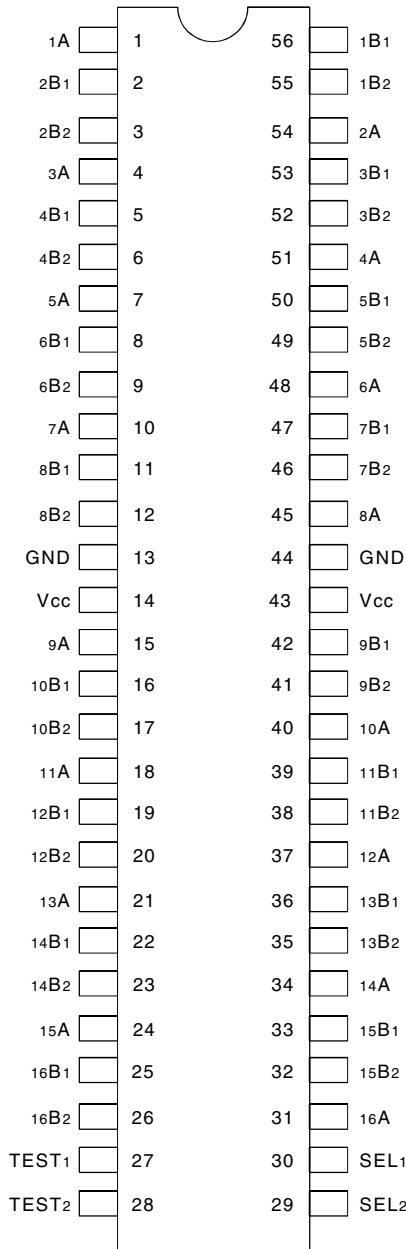

SSOP/ TSSOP
TOP VIEW

ABSOLUTE MAXIMUM RATINGS⁽¹⁾

Symbol	Description	Max.	Unit
VTERM ⁽²⁾	Supply Voltage to Ground	- 0.5 to 4.6	V
VTERM ⁽³⁾	DC Switch Voltage Vs	- 0.5 to 5.5	V
VTERM ⁽³⁾	DC Input Voltage VIN	- 0.5 to 5.5	V
VAC	AC Input Voltage (pulse width ≤20ns)	- 3	V
IOUT	DC Output Current (max. current/pin)	120	mA
TSTG	Storage Temperature	-65 to +150	°C

NOTES:

- Stresses greater than those listed under ABSOLUTE MAXIMUM RATINGS may cause permanent damage to the device. This is a stress rating only and functional operation of the device at these or any other conditions above those indicated in the operational sections of this specification is not implied. Exposure to absolute maximum rating conditions for extended periods may affect reliability.
- Vcc terminals.
- All terminals except Vcc.

CAPACITANCE (TA = +25°C, f = 1MHz, VIN = 0V, VOUT = 0V)

Symbol	Parameter ⁽¹⁾	Typ.	Max.	Unit	
CIN	Control Inputs	3	5	pF	
C/I/O	Quickswitch Channels (Switch OFF)	Mux	8	12	pF
		Demux	4	6	
C/I/O	Quickswitch Channels (Switch ON)	Mux	16	24	pF
		Demux	8	12	

NOTE:

- This parameter is guaranteed but not production tested.

PIN DESCRIPTION

Pin Names	I/O	Description
xA	I/O	Bus A
xBx	I/O	Bus B
SELx	I	Data Select
TESTx	I	Port Select

FUNCTION TABLE⁽¹⁾

SELx	TESTx	xA	Function
L	L	xB1	xA to xB1
H	L	xB2	xA to xB2
X	H	xB1, xB2	xA to xB1 and xB2

NOTE:

- H = HIGH Voltage Level
 L = LOW Voltage Level
 X = Don't Care



SEMICONDUCTOR
TECHNICAL DATA

KIC7SZ08FU
SILICON MONOLITHIC CMOS
DIGITAL INTEGRATED CIRCUIT

2 INPUT AND GATE

FEATURES

- High Output Drive : $\pm 24\text{mA}$ (Typ.)
@ $V_{CC}=3\text{V}$
- Super High Speed Operation : $t_{PD}=2.7\text{ns}$ (Typ.)
@ $V_{CC}=5\text{V}$, 50pF
- Operation Voltage Range : $V_{CC(oper)}=1.8\sim 5.5\text{V}$.
- Supply Voltage Data Retention : $V_{CC}=1.5\sim 5.5\text{V}$.
- 5V Tolerant Function

MAXIMUM RATINGS

CHARACTERISTIC	SYMBOL	RATING	UNIT
Supply Voltage Range	V_{CC}	-0.5~6	V
DC Input Voltage	V_{IN}	-0.5~6	V
DC Output Voltage	V_{OUT}	-0.5~6	V
Input Diode Current	I_{IK}	± 20	mA
Output Diode Current	I_{OK}	± 20	mA
DC Output Current	I_{OUT}	± 50	mA
DC V_{CC} /Ground Current	I_{CC}	± 50	mA
Power Dissipation	P_D	200	mW
Storage Temperature	T_{stg}	-65~150	$^{\circ}\text{C}$
Lead Temperature (10s)	T_L	260	$^{\circ}\text{C}$

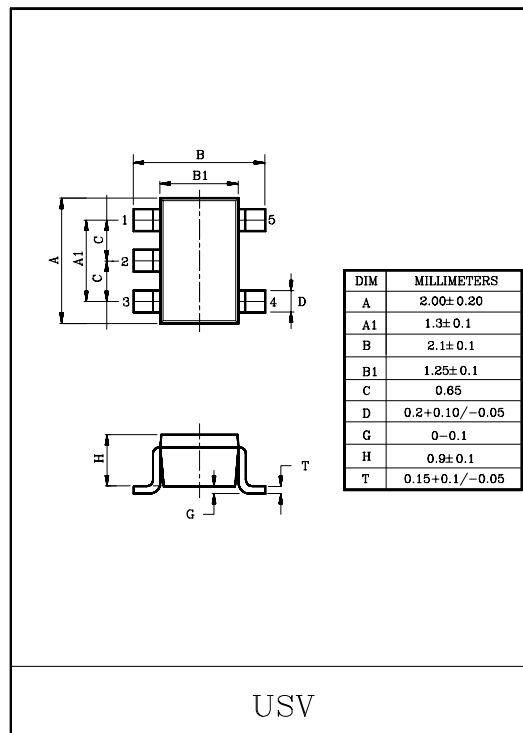

MARKING

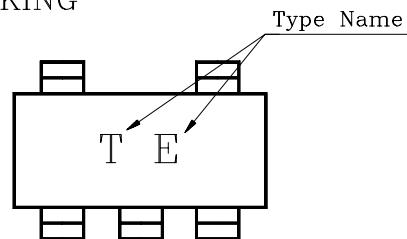

PIN CONNECTION(TOP VIEW)

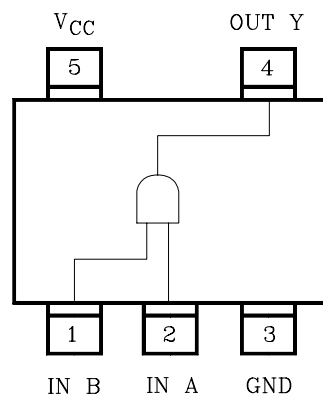



NJM2845/46

LOW DROPOUT VOLTAGE REGULATOR

■ GENERAL DESCRIPTION

The NJM2845 is low dropout voltage regulator. Advanced Bipolar technology achieves low noise, high ripple rejection and low quiescent current.

NJM2845 is 3 terminal type and NJM2846 is ON/OFF control built in type. These product can be selected according to the applications.

■ PACKAGE OUTLINE

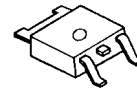

NJM2845DL1

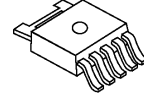

NJM2846DL3

■ FEATURES

- High Ripple Rejection 75dB typ. (f=1kHz,3V Version)
- Output Noise Voltage $V_{no}=45\mu V_{rms}$ typ. ($V_o=3V$ Version)
- Output capacitor with 2.2 μF ceramic capacitor ($V_o\geq 2.6V$)
- Output Current $I_o(max.)=800mA$
- High Precision Output $V_o \pm 1.0\%$
- Low Dropout Voltage 0.18V typ. ($I_o=500mA$)
- ON/OFF Control (NJM2846)
- Internal Short Circuit Current Limit
- Internal Thermal Overload Protection
- Bipolar Technology
- Package Outline TO-252-3 (NJM2845DL1), TO-252-5 (NJM2846DL3)

■ PIN CONFIGURATION

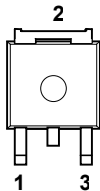

NJM2845DL1

- 1. V_{IN}
- 2. GND
- 3. V_{OUT}

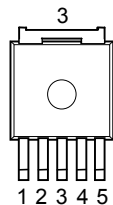

NJM2846DL3

- 1. CONTROL
- 2. V_{IN}
- 3. GND
- 4. V_o
- 5. NC

■ EQUIVALENT CIRCUIT

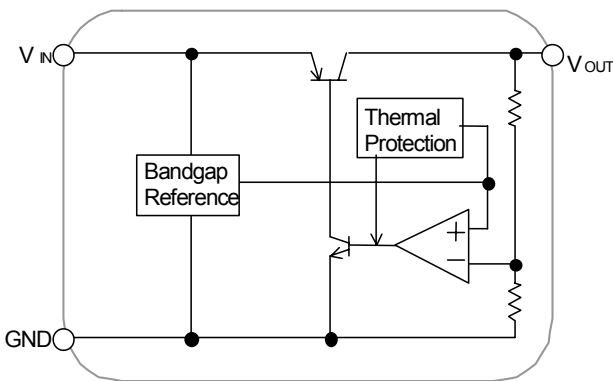

NJM2845DL1

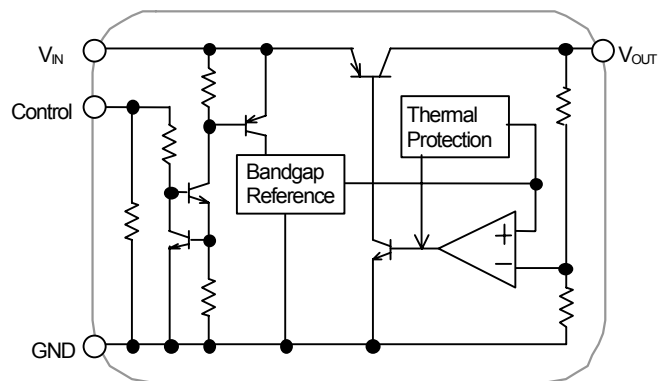

NJM2846DL3

TOSHIBA

TC74VHC157F/FN/FT

TOSHIBA CMOS DIGITAL INTEGRATED CIRCUIT SILICON MONOLITHIC

TC74VHC157F, TC74VHC157FN, TC74VHC157FT

QUAD 2 - CHANNEL MULTIPLEXER

The TC74VHC157 is an advanced high speed CMOS QUAD 2 - CHANNEL MULTIPLEXER fabricated with silicon gate C²MOS technology.

It achieves the high speed operation similar to equivalent Bipolar Schottky TTL while maintaining the CMOS low power dissipation.

It consists of four 2 - input digital multiplexers with common select and strobe inputs.

When the STROBE input is held "H" level, selection of data is inhibited and all the outputs become "L" level.

The SELECT decoding determines whether the A or B inputs get routed to their corresponding Y outputs.

An Input protection circuit ensures that 0 to 5.5V can be applied to the input pins without regard to the supply voltage. This device can be used to interface 5V to 3V systems and on two supply systems such as battery back up. This circuit prevents device destruction due to mismatched supply and input voltages.

FEATURES :

- High Speed..... $t_{pd} = 4.1ns(\text{typ.})$ at $V_{CC} = 5V$
- Low Power Dissipation..... $I_{CC} = 4\mu A(\text{Max.})$ at $T_a = 25^{\circ}C$
- High Noise Immunity..... $V_{NIH} = V_{NIL} = 28\% V_{CC} (\text{Min.})$
- Power Down Protection is provided on all inputs.
- Balanced Propagation Delays..... $t_{pLH} \approx t_{pHL}$
- Wide Operating Voltage Range..... $V_{CC} (\text{opr}) = 2V \sim 5.5V$
- Low Noise $V_{OLP} = 0.8V (\text{Max.})$
- Pin and Function Compatible with 74ALS157

TRUTH TABLE

INPUTS				OUTPUT
ST	SELECT	A	B	
H	X	X	X	L
L	L	L	X	L
L	L	H	X	H
L	H	X	L	L
L	H	X	H	H

X : Don't Care

(Note) The JEDEC SOP (FN) is not available in Japan.

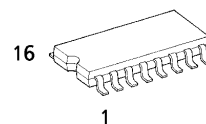

F (SOP16-P-300-1.27)
Weight : 0.18g (Typ.)

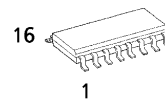

FN (SOL16-P-150-1.27)
Weight : 0.13g (Typ.)

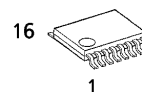

FT (TSSOP16-P-0044-0.65)
Weight : 0.06g (Typ.)

PIN ASSIGNMENT

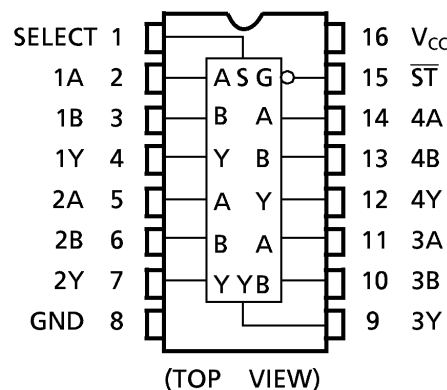

IEC LOGIC SYMBOL

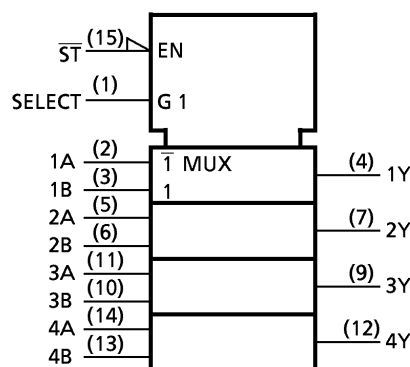

980910EBA2

● TOSHIBA is continually working to improve the quality and the reliability of its products. Nevertheless, semiconductor devices in general can malfunction or fail due to their inherent electrical sensitivity and vulnerability to physical stress. It is the responsibility of the buyer, when utilizing TOSHIBA products, to observe standards of safety, and to avoid situations in which a malfunction or failure of a TOSHIBA product could cause loss of human life, bodily injury or damage to property. In developing your designs, please ensure that TOSHIBA products are used within specified operating ranges as set forth in the most recent products specifications. Also, please keep in mind the precautions and conditions set forth in the TOSHIBA Semiconductor Reliability Handbook.

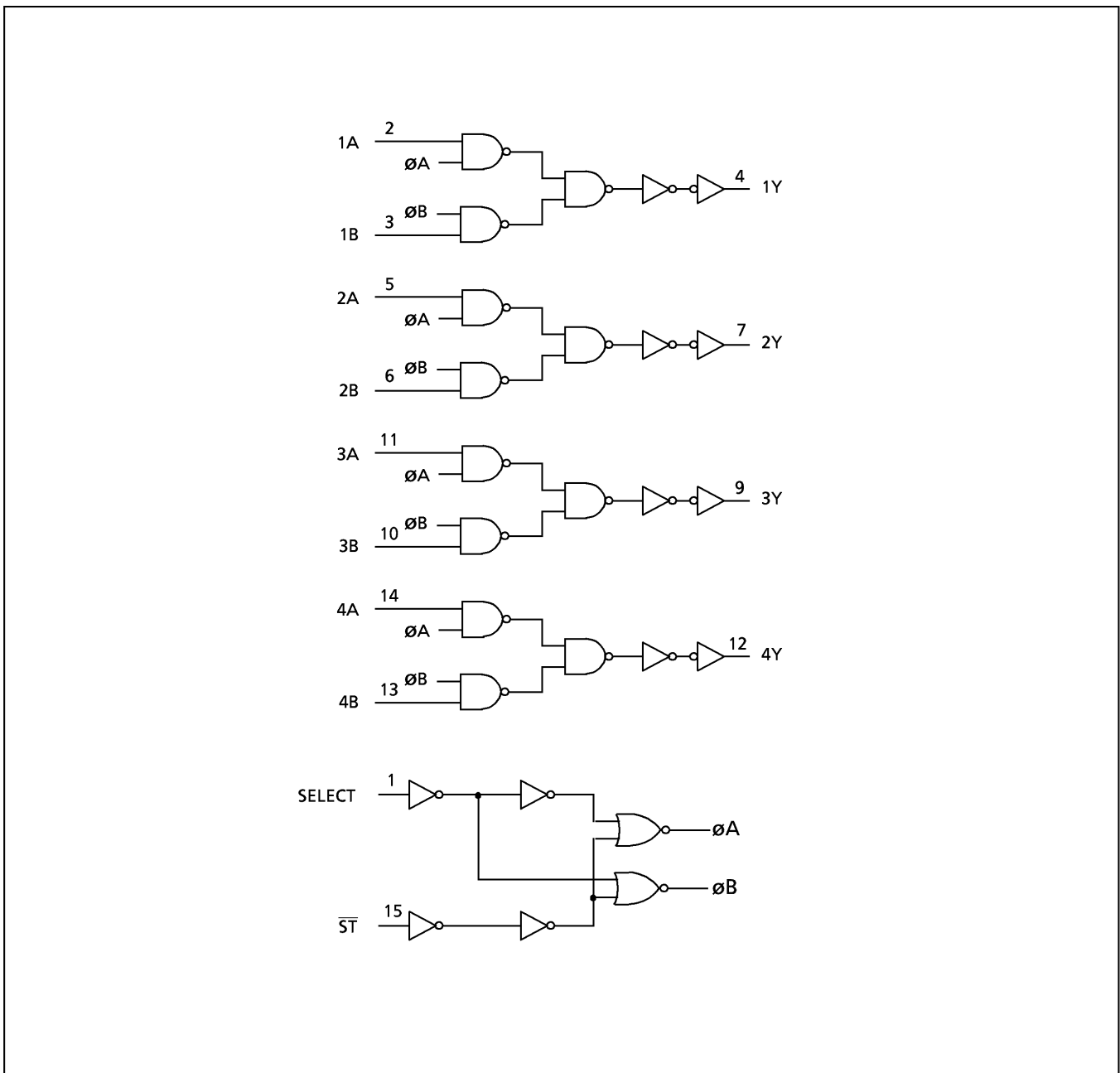
TOSHIBA**TC74VHC157F/FN/FT****SYSTEM DIAGRAM**

980910EBA2'

- The products described in this document are subject to the foreign exchange and foreign trade laws.
- The information contained herein is presented only as a guide for the applications of our products. No responsibility is assumed by TOSHIBA CORPORATION for any infringements of intellectual property or other rights of the third parties which may result from its use. No license is granted by implication or otherwise under any intellectual property or other rights of TOSHIBA CORPORATION or others.
- The information contained herein is subject to change without notice.

1999-10-28 2/6



CS495xx Data Sheet

FEATURES

- ❑ Powerful 32-bit Dual-core Audio DSP
- ❑ Multi-standard 32-bit Audio Decoding plus Post Processing, Dual-decode Capable
- ❑ Framework Applications Library
 - Dolby® Digital Pro Logic® IIx, Dolby® Digital EX, Dolby® Digital Headphone™, Dolby® Digital Virtual Speaker™
 - DTS-ES 96/24™, DTS-ES™ Discrete 6.1, DTS-ES™ Matrix 6.1, DTS® Digital Surround
 - MPEG-2 Multichannel
 - AAC™ Multichannel 5.1
 - MP3 – MPEG-1/2, Layer III
 - THX® Surround EX™, THX® Ultra2 Cinema™
 - DVD Audio/Video/SACD Multichannel Bass Management
- ❑ 10 Channels of 32-bit Serial Audio Input
- ❑ 16 Channels of 32-bit PCM Output
- ❑ Two Master/slave SPI or I²C Format Control Ports for Audio Subsystem Management
- ❑ Parallel Host Control & UART
- ❑ Customer Software Security Keys
- ❑ Large On-chip X, Y, and Program RAM & ROM
- ❑ SDRAM, SRAM, and FLASH Memory Support
- ❑ Dual 192-kHz SPDIF Transmitters

32-bit Audio Decoder DSP Family

The CS495xx DSP family integrates two programmable, 32-bit DSP cores and a DMA engine with a full set of audio peripherals. Feature-rich AVR designs can be easily developed using the Framework applications library, which includes both certified application programs and a modular programming environment for easy customization. The framework includes certified state-of-the-art audio decoders, virtualizers, surround simulators, and audio enhancement algorithms.

The CS495xx family was designed to reduce system costs and development time and to provide advanced features and flexibility for competitive system-level solutions. The difficult processing tasks of Dolby® Digital Surround EX™, AAC multichannel, DTS-ES 96/24, and THX Ultra2 Cinema can be accomplished without the expense of external logic or memory. Additionally, the CS495xx can meet the needs of dual-decode applications with twin DSP cores, and audio-I/O-intensive designs with support for up to 10 input and 16 output channels.

Ordering Information

See page 33 for ordering information

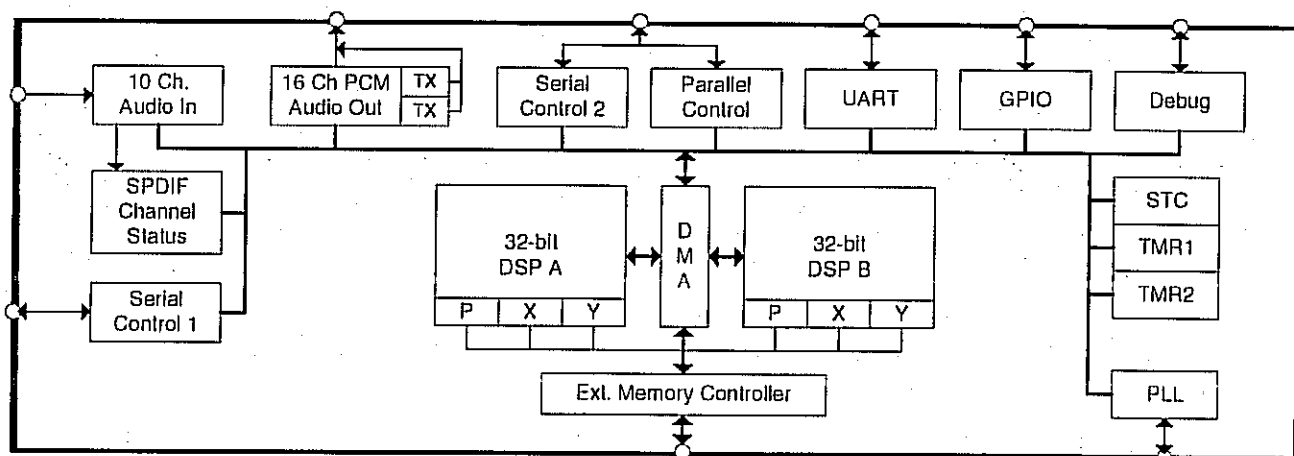

Preliminary Product Information

This document contains information for a new product.
Cirrus Logic reserves the right to modify this product without notice.

CIRRUS LOGIC
<http://www.cirrus.com>

©Copyright 2005 Cirrus Logic, Inc.

NOV '05
DS631PP4



7. Package Pinout, 144-Pin QFP/LQFP

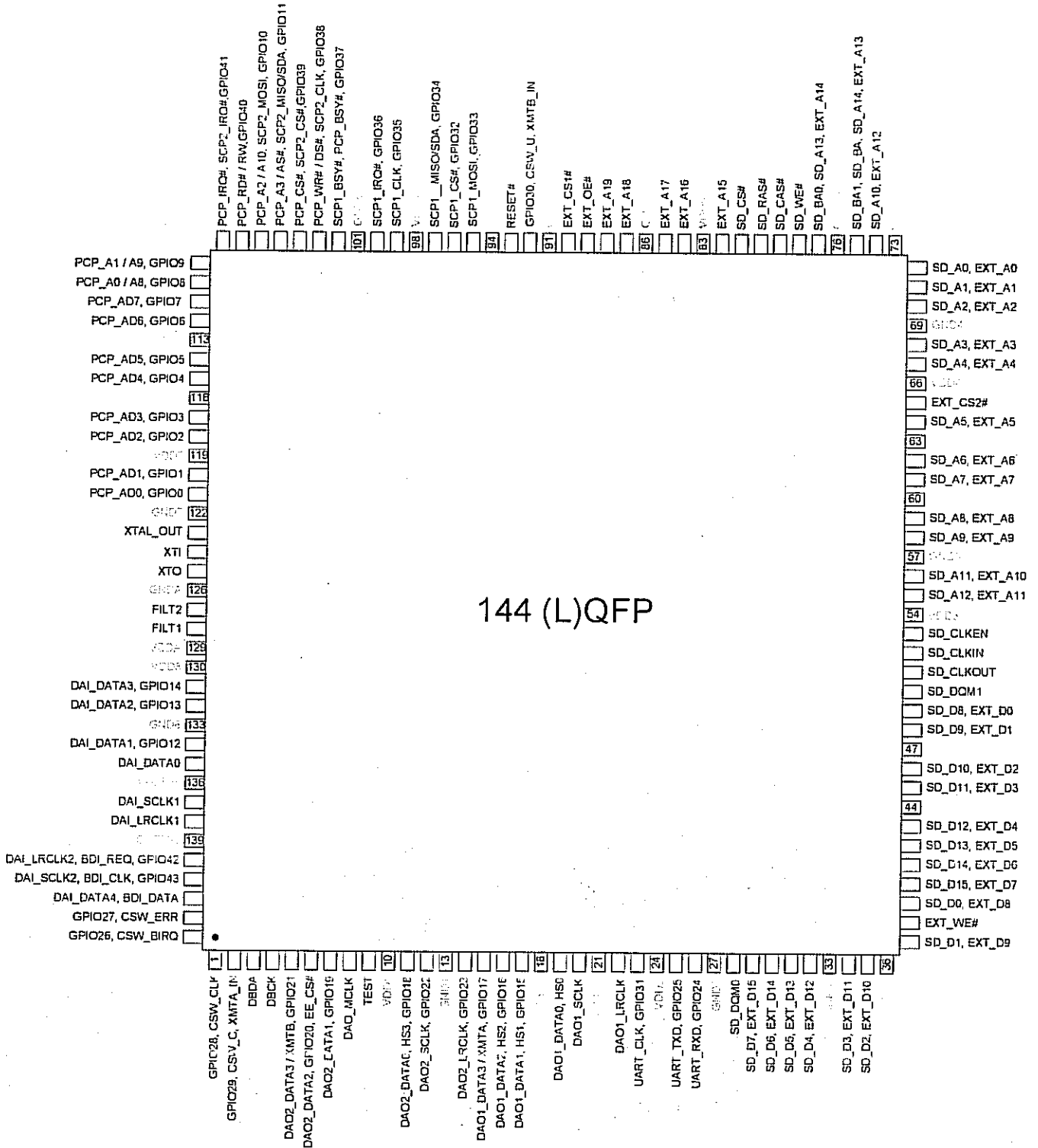

Figure 23. 144-Pin (L)QFP Package Pinout



8 Mbit SPI Serial Flash

SST25VF080B

Data Sheet

FEATURES:

- **Single Voltage Read and Write Operations**
 - 2.7-3.6V
- **Serial Interface Architecture**
 - SPI Compatible: Mode 0 and Mode 3
- **High Speed Clock Frequency**
 - 50 MHz
- **Superior Reliability**
 - Endurance: 100,000 Cycles (typical)
 - Greater than 100 years Data Retention
- **Low Power Consumption:**
 - Active Read Current: 10 mA (typical)
 - Standby Current: 5 μ A (typical)
- **Flexible Erase Capability**
 - Uniform 4 KByte sectors
 - Uniform 32 KByte overlay blocks
 - Uniform 64 KByte overlay blocks
- **Fast Erase and Byte-Program:**
 - Chip-Erase Time: 35 ms (typical)
 - Sector-/Block-Erase Time: 18 ms (typical)
 - Byte-Program Time: 7 μ s (typical)
- **Auto Address Increment (AAI) Programming**
 - Decrease total chip programming time over Byte-Program operations
- **End-of-Write Detection**
 - Software polling the BUSY bit in Status Register
 - Busy Status readout on SO pin in AAI Mode
- **Hold Pin (HOLD#)**
 - Suspends a serial sequence to the memory without deselecting the device
- **Write Protection (WP#)**
 - Enables/Disables the Lock-Down function of the status register
- **Software Write Protection**
 - Write protection through Block-Protection bits in status register
- **Temperature Range**
 - Commercial: 0°C to +70°C
 - Industrial: -40°C to +85°C
- **Packages Available**
 - 8-lead SOIC (200 mils)
 - 8-contact WSON (6mm x 5mm)
- **All non-Pb (lead-free) devices are RoHS compliant**

PRODUCT DESCRIPTION

SST's 25 series Serial Flash family features a four-wire, SPI-compatible interface that allows for a low pin-count package which occupies less board space and ultimately lowers total system costs. The SST25VF080B devices are enhanced with improved operating frequency and even lower power consumption than the original SST25VFxxxA devices. SST25VF080B SPI serial flash memories are manufactured with SST's proprietary, high-performance CMOS SuperFlash technology. The split-gate cell design and thick-oxide tunneling injector attain better reliability and manufacturability compared with alternate approaches.

The SST25VF080B devices significantly improve performance and reliability, while lowering power consumption. The devices write (Program or Erase) with a single power supply of 2.7-3.6V for SST25VF080B. The total energy consumed is a function of the applied voltage, current, and time of application. Since for any given voltage range, the SuperFlash technology uses less current to program and has a shorter erase time, the total energy consumed during any Erase or Program operation is less than alternative flash memory technologies.

The SST25VF080B device is offered in both 8-lead SOIC (200 mils) and 8-contact WSON (6mm x 5mm) packages. See Figure 1 for pin assignments.



**8 Mbit SPI Serial Flash
SST25VF080B**

Data Sheet

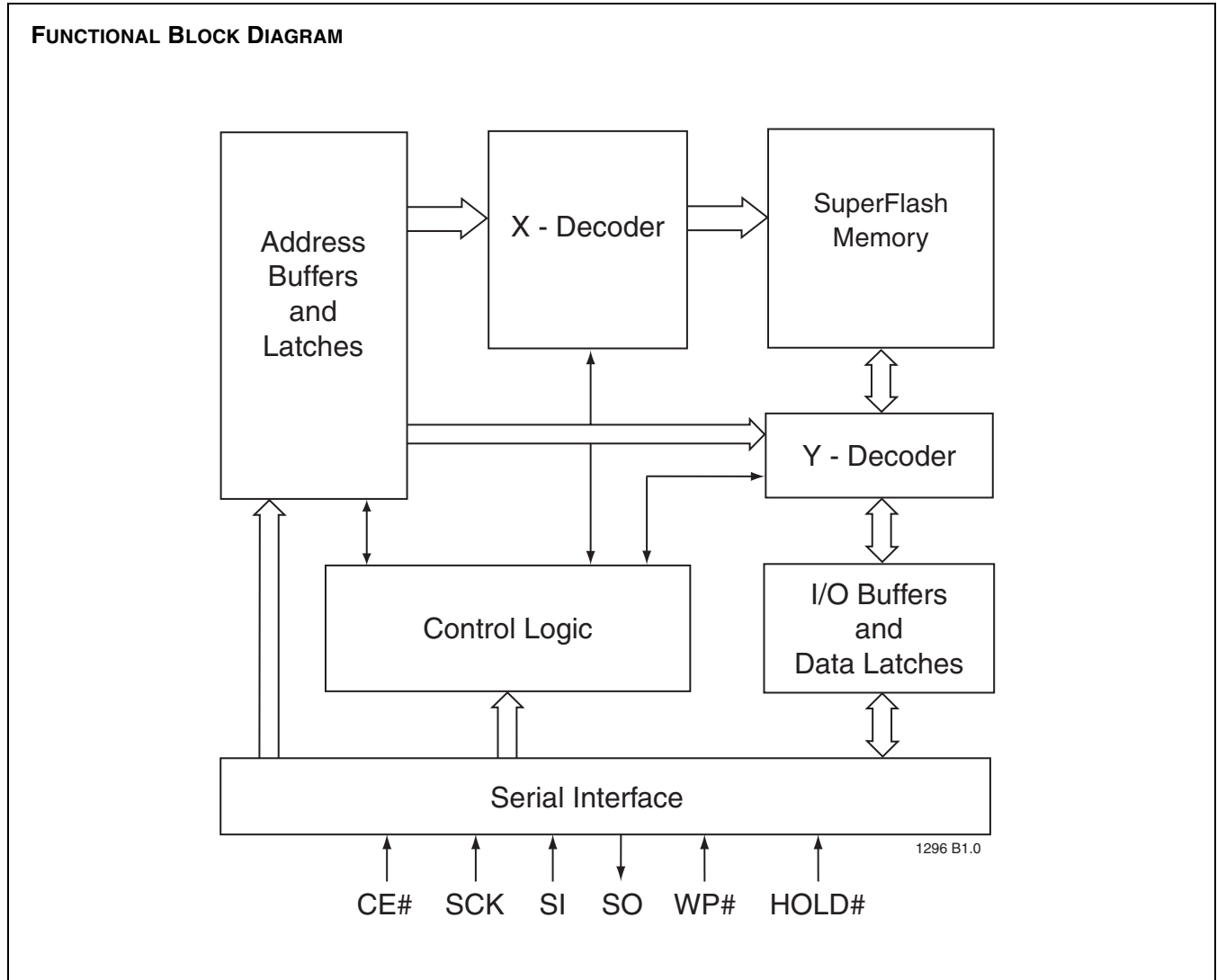



8 Mbit SPI Serial Flash SST25VF080B

PIN DESCRIPTION

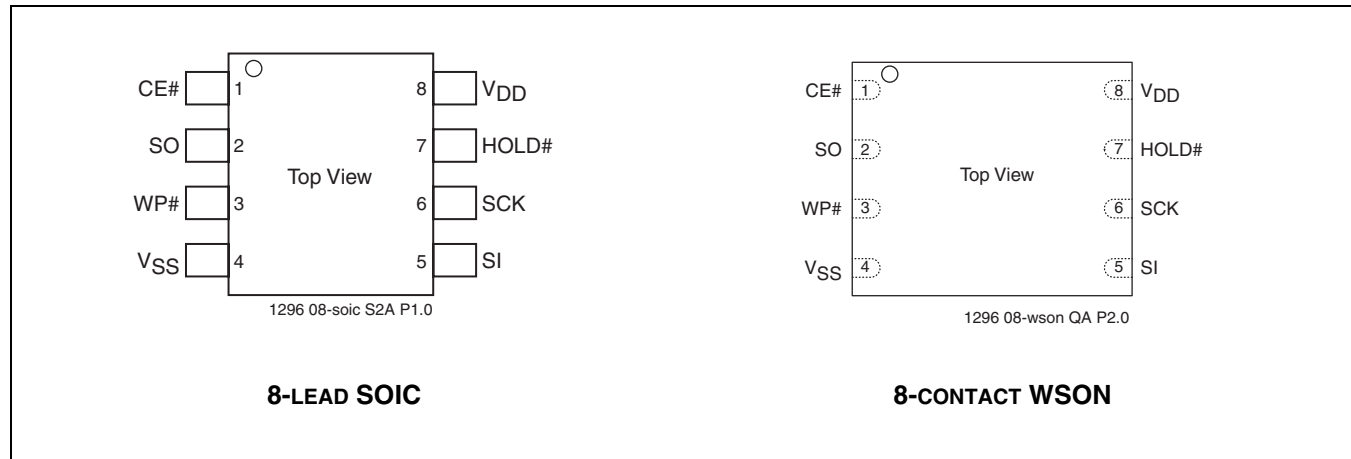

FIGURE 1: PIN ASSIGNMENTS

TABLE 1: PIN DESCRIPTION

Symbol	Pin Name	Functions
SCK	Serial Clock	To provide the timing of the serial interface. Commands, addresses, or input data are latched on the rising edge of the clock input, while output data is shifted out on the falling edge of the clock input.
SI	Serial Data Input	To transfer commands, addresses, or data serially into the device. Inputs are latched on the rising edge of the serial clock.
SO	Serial Data Output	To transfer data serially out of the device. Data is shifted out on the falling edge of the serial clock. Outputs Flash busy status during AAI Programming when reconfigured as RY/BY# pin. See "Hardware End-of-Write Detection" on page 12 for details.
CE#	Chip Enable	The device is enabled by a high to low transition on CE#. CE# must remain low for the duration of any command sequence.
WP#	Write Protect	The Write Protect (WP#) pin is used to enable/disable BPL bit in the status register.
HOLD#	Hold	To temporarily stop serial communication with SPI flash memory without resetting the device.
V _{DD}	Power Supply	To provide power supply voltage: 2.7-3.6V for SST25VF080B
V _{SS}	Ground	

T1.0 1296

Technology

SiI 9031

HDMI PanelLink Cinema Receiver

Data Sheet

General Description

The SiI 9031 is a second generation PanelLink Cinema receiver that is compatible with the HDMI 1.1 (High Definition Multimedia Interface) specification. DTVs, plasma displays, LCD TVs and projectors can now provide the highest quality protected digital audio/video over a single cable. Backwards compatibility with DVI 1.0 allows HDMI systems to connect to existing DVI 1.0 hosts (DVD players, HD set top boxes, D-VHS players and receivers, PC).

The SiI 9031 is capable of receiving and outputting up to eight channel digital audio – an excellent solution for A/V Receivers. Four industry-standard I²S ports allow direct connection to high-performance audio DACs or DSPs up to 192kHz. An S/PDIF port supports up to 192 kHz audio.

The SiI 9031 enables A/V Receivers with full HDCP Repeater support, to receive, decrypt and output high quality video and audio to an HDMI transmitter. The SiI 9031 also comes pre-programmed with HDCP keys, greatly simplifying the manufacturing process, lowering costs, while providing the highest level of HDCP key security.

Silicon Image's PanelLink Cinema receivers use the latest generation of PanelLink TMDS core technology. These PanelLink cores pass all HDMI compliancy tests.

The SiI 9031 is offered in two speed varieties: SiI9031CTU (to 720p/1080i/SXGA) and SiI9031CTU-7 (to 1080p).

Features

- Dual-Input HDMI 1.1, HDCP 1.1 and DVI 1.0 compliant receiver
- Integrated PanelLink TMDS[®] core.
- Digital video interface supports video processors:
 - 24-bit RGB / YCbCr 4:4:4
 - 16/20/24-bit YCbCr 4:2:2
 - 8/10/12-bit YCbCr 4:2:2 (ITU BT.656)
 - 12-bit DMO (Digital Multimedia Output) RGB/YCbCr 4:4:4 (clocked with rising & falling edges)
 - Color Space Conversion for both RGB-to-YCbCr and YCbCr-to-RGB (both 601 and 709)
 - Auto video mode configuration simplifies system firmware design
- Analog RGB and YPbPr output:
 - 10-bit DAC
 - Separate or Composite Syncs (Sync on G)
- Digital audio interface supports high-end audio systems:
 - Four programmable I²S outputs for connection to low-cost DACs at 32-192kHz
 - S/PDIF output supports PCM, Dolby Digital, DTS digital audio transmission (32-192 kHz Fs) using IEC 60958 and IEC 61937
 - Programmable Channel Mapping for I²S Outputs
 - Auto audio error detection with programmable soft mute
- Integrated HDCP decryption engine for receiving protected audio and video content
 - Pre-programmed HDCP keys provide highest level of key security, simplifies manufacturing
 - Full support for HDCP Repeaters up to 15 attached downstream devices
- Software compatible with SiI 9993
- Flexible power management
- 144-pin TQFP package

Pin Diagram

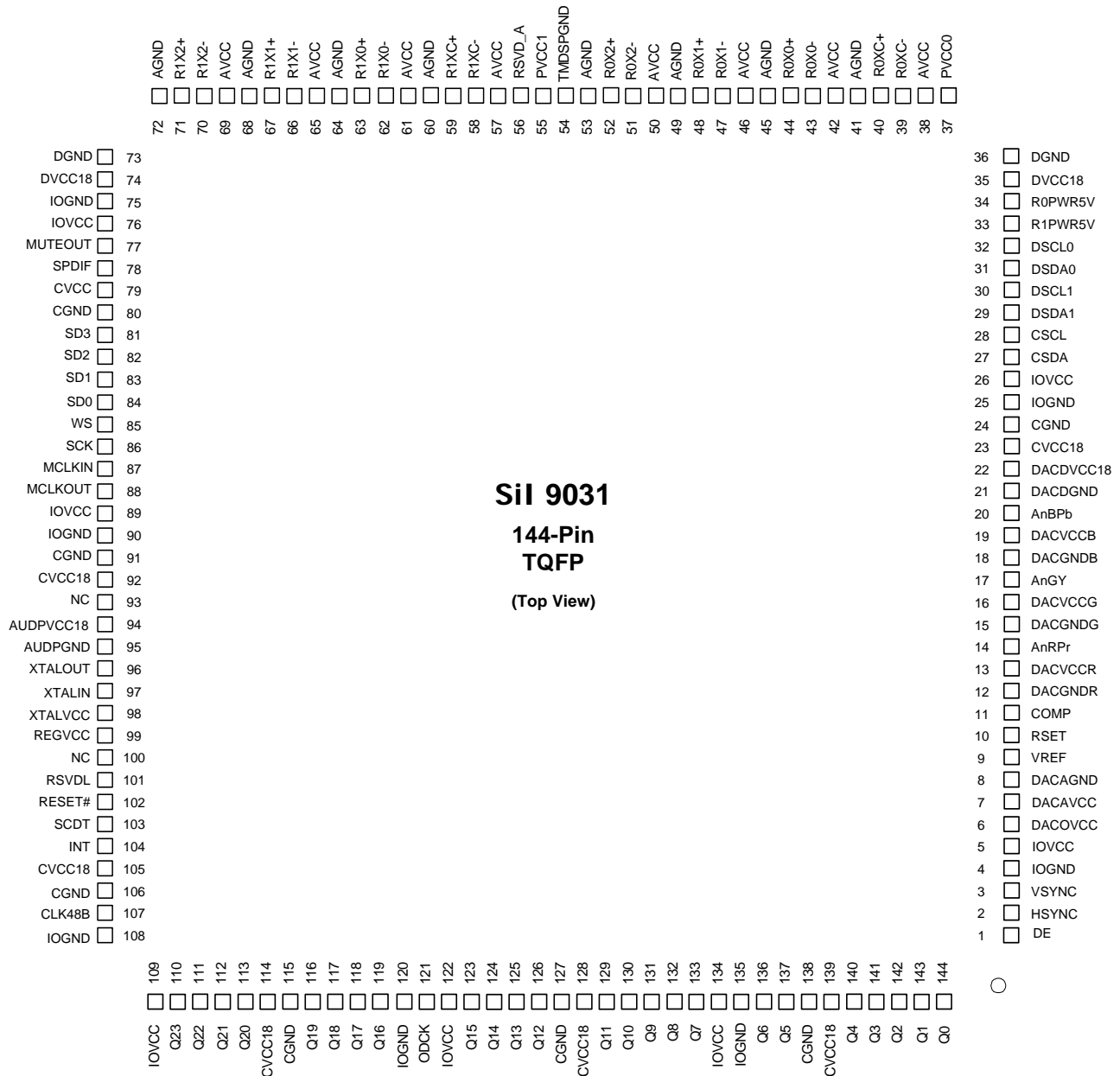

Figure 1. Pin Diagram

Individual pin functions are described beginning on page 37.

System Applications

A/V Receiver

In an A/V receiver, audio/video is accepted as inputs from one or more sources. A single SiI 9031 provides two HDMI input ports. These can be selected and combined into a single HDMI output through a SiI 9030 transmitter.

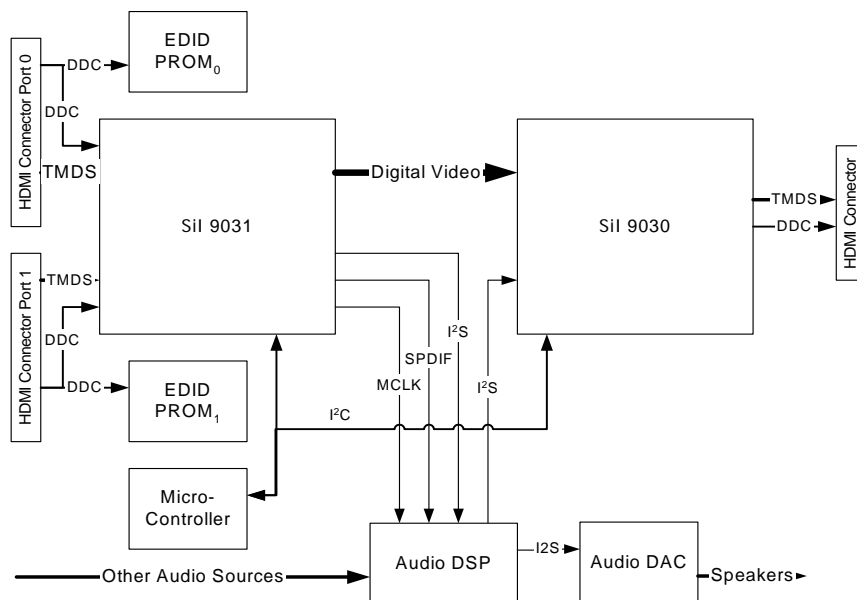

Figure 2. A/V Receiver Block Diagram

Functional Description

The SiI 9031 provides a complete solution for receiving HDMI compliant digital audio and video. Specialized audio and video processing is available within the SiI 9031 to easily and cost effectively add HDMI capability to consumer electronics devices such as A/V Receivers, digital TVs, plasma displays, LCD TVs and projectors. Figure 3 shows the functional blocks of the chip.

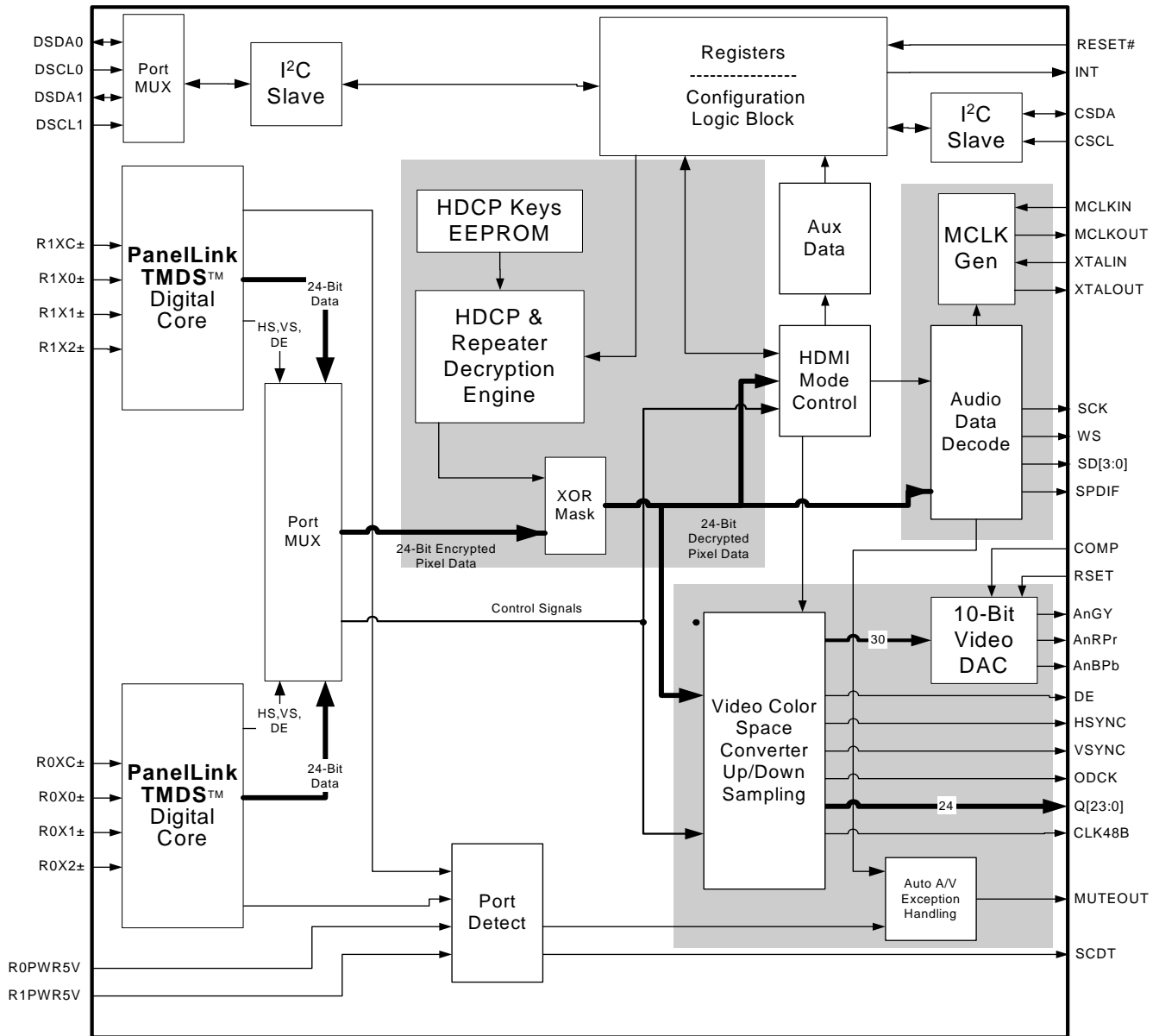

Figure 3. Functional Block Diagram

The SiI 9031 supports two HDMI input ports. Only one port may be active at any time.

Features

- Low-voltage and Standard-voltage Operation
 - 2.7 (V_{CC} = 2.7V to 5.5V)
 - 1.8 (V_{CC} = 1.8V to 5.5V)
- Internally Organized 128 x 8 (1K), 256 x 8 (2K), 512 x 8 (4K), 1024 x 8 (8K) or 2048 x 8 (16K)
- Two-wire Serial Interface
- Schmitt Trigger, Filtered Inputs for Noise Suppression
- Bidirectional Data Transfer Protocol
- 100 kHz (1.8V) and 400 kHz (2.7V, 5V) Compatibility
- Write Protect Pin for Hardware Data Protection
- 8-byte Page (1K, 2K), 16-byte Page (4K, 8K, 16K) Write Modes
- Partial Page Writes Allowed
- Self-timed Write Cycle (5 ms max)
- High-reliability
 - Endurance: 1 Million Write Cycles
 - Data Retention: 100 Years
- Automotive Grade and Lead-free/Halogen-free Devices Available
- 8-lead PDIP, 8-lead JEDEC SOIC, 8-lead MAP, 5-lead SOT23, 8-lead TSSOP and 8-ball dBGA2 Packages
- Die Sales: Wafer Form, Waffle Pack and Bumped Wafers

Description

The AT24C01A/02/04/08A/16A provides 1024/2048/4096/8192/16384 bits of serial electrically erasable and programmable read-only memory (EEPROM) organized as 128/256/512/1024/2048 words of 8 bits each. The device is optimized for use in many industrial and commercial applications where low-power and low-voltage operation are essential. The AT24C01A/02/04/08A/16A is available in space-saving 8-lead PDIP, 8-lead JEDEC SOIC, 8-lead MAP, 5-lead SOT23 (AT24C01A/AT24C02/AT24C04), 8-lead TSSOP, and 8-ball dBGA2 packages and is accessed via a Two-wire serial interface. In addition, the entire family is available in 2.7V (2.7V to 5.5V) and 1.8V (1.8V to 5.5V) versions.

Table 1. Pin Configuration

Pin Name	Function
A0 - A2	Address Inputs
SDA	Serial Data
SCL	Serial Clock Input
WP	Write Protect
NC	No Connect
GND	Ground
VCC	Power Supply

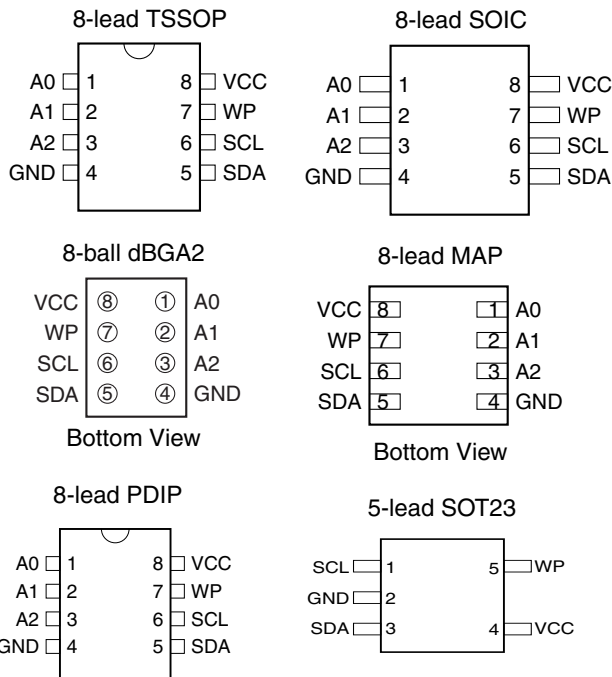

Two-wire Serial EEPROM

1K (128 x 8)

2K (256 x 8)

4K (512 x 8)

8K (1024 x 8)

16K (2048 x 8)

AT24C01A

AT24C02

AT24C04

AT24C08A

AT24C16A





Absolute Maximum Ratings

Operating Temperature	-55°C to +125°C
Storage Temperature	-65°C to +150°C
Voltage on Any Pin with Respect to Ground	-1.0V to +7.0V
Maximum Operating Voltage	6.25V
DC Output Current.....	5.0 mA

***NOTICE:** Stresses beyond those listed under “Absolute Maximum Ratings” may cause permanent damage to the device. This is a stress rating only and functional operation of the device at these or any other conditions beyond those indicated in the operational sections of this specification is not implied. Exposure to absolute maximum rating conditions for extended periods may affect device reliability.

Figure 1. Block Diagram

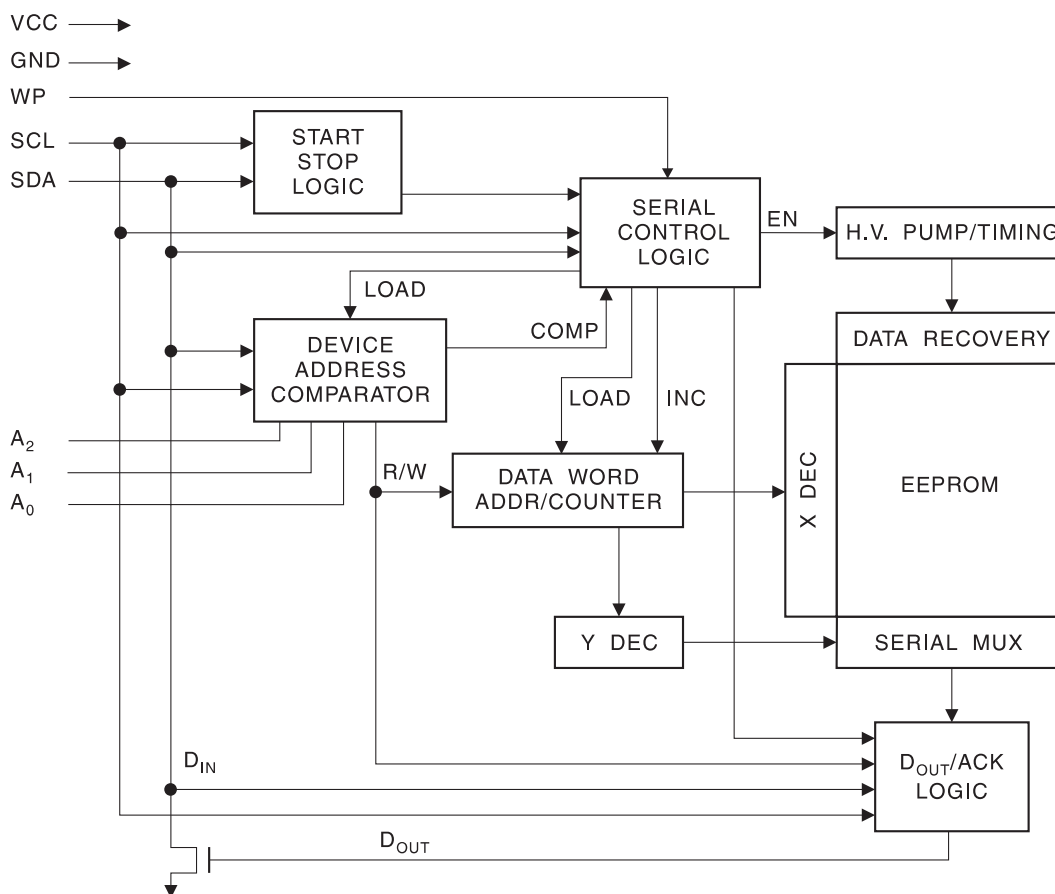

AT24C01A/02/04/08A/16A

Pin Description

SERIAL CLOCK (SCL): The SCL input is used to positive edge clock data into each EEPROM device and negative edge clock data out of each device.

SERIAL DATA (SDA): The SDA pin is bidirectional for serial data transfer. This pin is open-drain driven and may be wire-ORed with any number of other open-drain or open-collector devices.

DEVICE/PAGE ADDRESSES (A2, A1, A0): The A2, A1 and A0 pins are device address inputs that are hard wired for the AT24C01A and the AT24C02. As many as eight 1K/2K devices may be addressed on a single bus system (device addressing is discussed in detail under the Device Addressing section).

The AT24C04 uses the A2 and A1 inputs for hard wire addressing and a total of four 4K devices may be addressed on a single bus system. The A0 pin is a no connect.

The AT24C08A only uses the A2 input for hardwire addressing and a total of two 8K devices may be addressed on a single bus system. The A0 and A1 pins are no connects.

The AT24C16A does not use the device address pins, which limits the number of devices on a single bus to one. The A0, A1 and A2 pins are no connects.

WRITE PROTECT (WP): The AT24C01A/02/04/08A/16A has a Write Protect pin that provides hardware data protection. The Write Protect pin allows normal Read/Write operations when connected to ground (GND). When the Write Protect pin is connected to V_{CC} , the write protection feature is enabled and operates as shown in Table 2.

Table 2. Write Protect

WP Pin Status	Part of the Array Protected				
	24C01A	24C02	24C04	24C08A	24C16A
At V_{CC}	Full (1K) Array	Full (2K) Array	Full (4K) Array	Full (8K) Array	Full (16K) Array
At GND	Normal Read/Write Operations				

Memory Organization AT24C01A, 1K SERIAL EEPROM: Internally organized with 16 pages of 8 bytes each, the 1K requires a 7-bit data word address for random word addressing.

AT24C02, 2K SERIAL EEPROM: Internally organized with 32 pages of 8 bytes each, the 2K requires an 8-bit data word address for random word addressing.

AT24C04, 4K SERIAL EEPROM: Internally organized with 32 pages of 16 bytes each, the 4K requires a 9-bit data word address for random word addressing.

AT24C08A, 8K SERIAL EEPROM: Internally organized with 64 pages of 16 bytes each, the 8K requires a 10-bit data word address for random word addressing.

AT24C16A, 16K SERIAL EEPROM: Internally organized with 128 pages of 16 bytes each, the 16K requires an 11-bit data word address for random word addressing.



M54HCU04
M74HCU04

HEX INVERTER (SINGLE STAGE)

- HIGH SPEED
 $t_{PD} = 5 \text{ ns (TYP.) AT } V_{CC} = 5 \text{ V}$
- LOW POWER DISSIPATION
 $I_{CC} = 1 \mu\text{A (MAX.) AT } T_A = 25 \text{ }^\circ\text{C}$
- HIGH NOISE IMMUNITY
 $V_{NIH} = V_{NIL} = 10 \% V_{CC} \text{ (MIN.)}$
- OUTPUT DRIVE CAPABILITY
 10 LSTTL LOADS
- SYMMETRICAL OUTPUT IMPEDANCE
 $|I_{OH}| = I_{OL} = 4 \text{ mA (MIN.)}$
- BALANCED PROPAGATION DELAYS
 $t_{PLH} = t_{PHL}$
- WIDE OPERATING VOLTAGE RANGE
 $V_{CC} \text{ (OPR)} = 2 \text{ V TO } 6 \text{ V}$
- PIN AND FUNCTION COMPATIBLE WITH
 54/74LS04

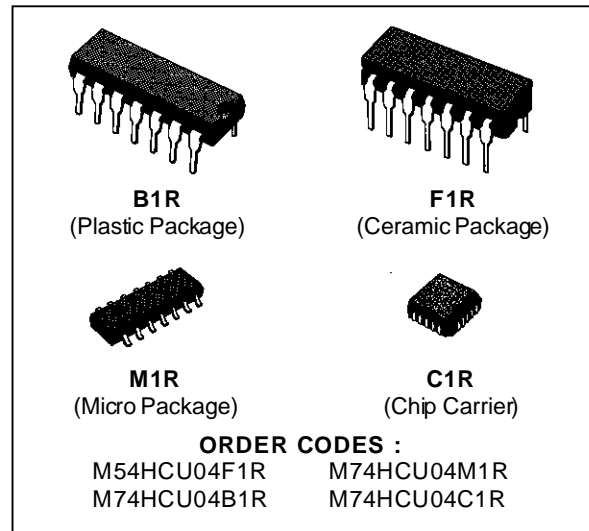

DESCRIPTION

The M54/74HCU04 is a high speed CMOS HEX INVERTER (SINGLE STAGE) fabricated in silicon gate C²MOS technology. It has the same high speed performance of LSTTL combined with true CMOS low power consumption.

As the intrnal circuit is composed of a single stage inverter, it can be used in crystal oscillator.

All inputs are equipped with circuits against static discharge and transient excess voltage.

INPUT AND OUTPUT EQUIVALENT CIRCUIT

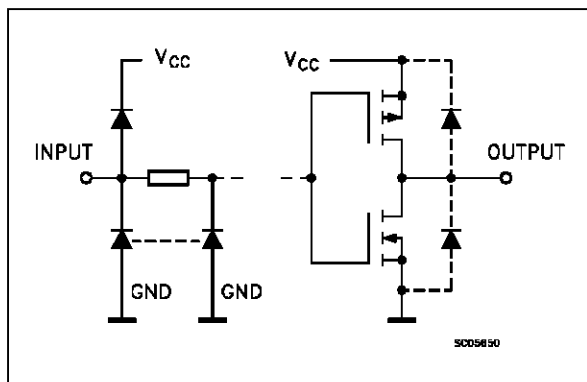

PIN CONNECTIONS (top view)

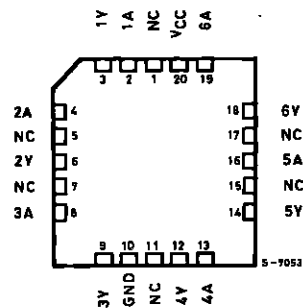
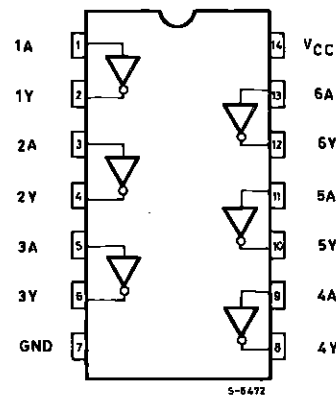

NC =
No Internal
Connection

■ PIN ASSIGNMENT (74HCU04AFN : IC72,76)

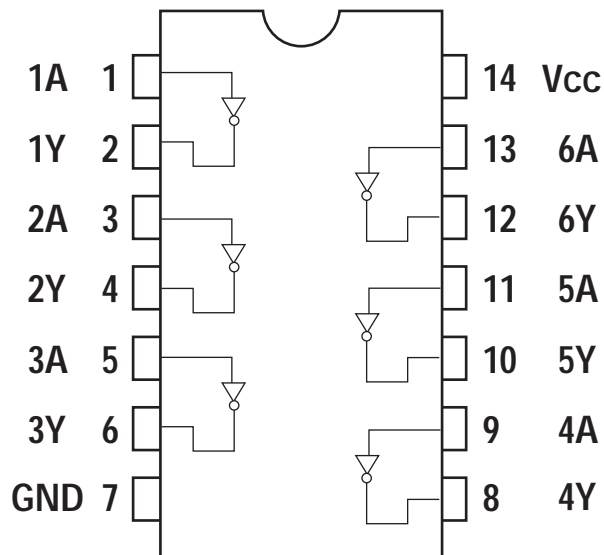

■ LOGIC SYMBOL

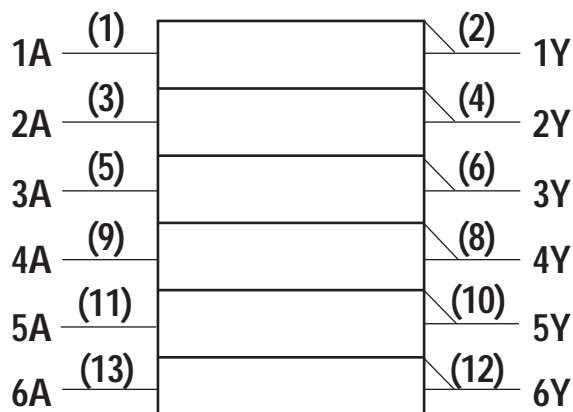

■ TRUTH TABLE

A	Y
L	H
H	L

RICOH**LOW DROP-OUT AND LOW NOISE
VOLTAGE REGULATOR****RN5RZ SERIES****OUTLINE**

IC98	HVIRN5RZ50BA	REGULATOR 5V (SOT-23-5)
------	--------------	-------------------------

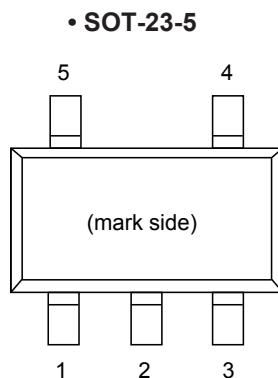
RN5RZ**PIN CONFIGURATION****PIN DESCRIPTION**

Pin No.	Symbol	Description
1	GND	Ground Pin
2	V _{DD}	Input Pin
3	V _{OUT}	Output Pin
4	NC	No Connection
5	CE or $\overline{\text{CE}}$	Chip Enable Pin

Symbol	Item	Ratings	Unit
V _{IN}	Input Voltage	9	V
V _{CE}	Input Voltage (CE or $\overline{\text{CE}}$ Pin)	-0.3 to V _{IN} +0.3	V
V _{OUT}	Output Voltage	-0.3 to V _{IN} +0.3	V
I _{OUT}	Output Current	200	mA
P _D	Power Dissipation	250	mW
T _{opt}	Operating Temperature	-40 to +85	°C
T _{stg}	Storage Temperature	-55 to +125	°C



HY57V161610ETP-I

2 Banks x 512K x 16 Bit Synchronous DRAM

DESCRIPTION

THE Hynix HY57V161610E is a 16,777,216-bits CMOS Synchronous DRAM, ideally suited for the main memory and graphic applications which require large memory density and high bandwidth. HY57V161610E is organized as 2banks of 524,288x16.

HY57V161610E is offering fully synchronous operation referenced to a positive edge clock. All inputs and outputs are synchronized with the rising edge of the clock input. The data paths are internally pipelined to achieve very high bandwidth. All input and output voltage levels are compatible with LVTTTL.

Programmable options include the length of pipeline (Read latency of 1,2 or 3), the number of consecutive read or write cycles initiated by a single control command (Burst length of 1,2,4,8 or full page), and the burst count sequence(sequential or interleave). A burst of read or write cycles in progress can be terminated by a burst terminate command or can be interrupted and replaced by a new burst read or write command on any cycle. (This pipeline design is not restricted by a `2N` rule.)

FEATURES

- Single 3.0V to 3.6V power supply
- All device pins are compatible with LVTTTL interface
- JEDEC standard 400mil 50pin TSOP-II with 0.8mm of pin pitch
- All inputs and outputs referenced to positive edge of system clock
- Data mask function by UDQM/LDQM
- Internal two banks operation
- Auto refresh and self refresh
- 4096 refresh cycles / 64ms
- Programmable Burst Length and Burst Type
 - 1, 2, 4, 8 and Full Page for Sequence Burst
 - 1, 2, 4 and 8 for Interleave Burst
- Programmable $\overline{\text{CAS}}$ Latency ; 1, 2, 3 Clocks
- Pb-free Package

ORDERING INFORMATION

Part No.	Clock Frequency	Organization	Interface	Package
HY57V161610ETP-5I	200MHz	2Banks x 512Kbits x 16	LVTTTL	400mil 50pin TSOP II (Pb free)
HY57V161610ETP-55I	183MHz			
HY57V161610ETP-6I	166MHz			
HY57V161610ETP-7I	143MHz			
HY57V161610ETP-8I	125MHz			
HY57V161610ETP-10I	100MHz			
HY57V161610ETP-15I	66MHz			

Note :

1. VDD(min) of HY57V161610ETP-5I/55I is 3.15V
2. Hynix supports lead free part for each speed grade with same specification.

This document is a general product description and is subject to change without notice. Hynix Semiconductor does not assume any responsibility for use of circuits described. No patent licenses are implied

Rev. 0.1 / Nov. 2003

1



HY57V161610ETP-I

PIN CONFIGURATION

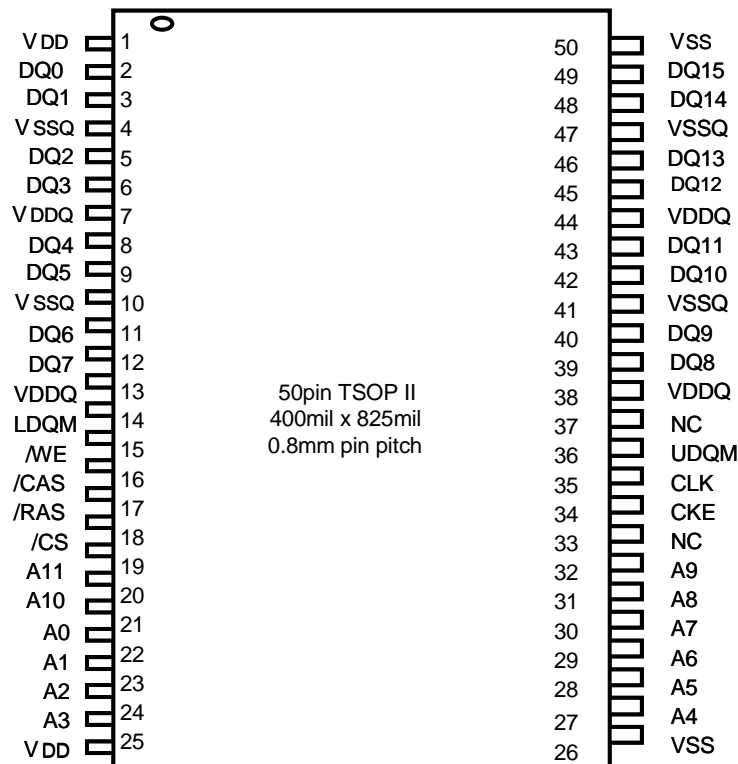

PIN DESCRIPTION

PIN	PIN NAME	DESCRIPTION
CLK	Clock	The system clock input. All other inputs are referenced to the SDRAM on the rising edge of CLK.
CKE	Clock Enable	Controls internal clock signal and when deactivated, the SDRAM will be one of the states among power down, suspend or self refresh.
$\overline{\text{CS}}$	Chip Select	Command input enable or mask except CLK, CKE and DQM
BA	Bank Address	Select either one of banks during both $\overline{\text{RAS}}$ and $\overline{\text{CAS}}$ activity.
A0 ~ A10	Address	Row Address : RA0 ~ RA10, Column Address : CA0 ~ CA7 Auto-precharge flag : A10
$\overline{\text{RAS}}$, $\overline{\text{CAS}}$, $\overline{\text{WE}}$	Row Address Strobe, Column Address Strobe, Write Enable	$\overline{\text{RAS}}$, $\overline{\text{CAS}}$ and $\overline{\text{WE}}$ define the operation. Refer function truth table for details
LDQM, UDQM	Data Input/Output Mask	DQM control output buffer in read mode and mask input data in write mode
DQ0 ~ DQ15	Data Input/Output	Multiplexed data input / output pin
VDD/VSS	Power Supply/Ground	Power supply for internal circuit and input buffer
VDDQ/VSSQ	Data Output Power/Ground	Power supply for DQ
NC	No Connection	No connection



HY57V161610ETP-I

FUNCTIONAL BLOCK DIAGRAM

1Mx16 Synchronous DRAM

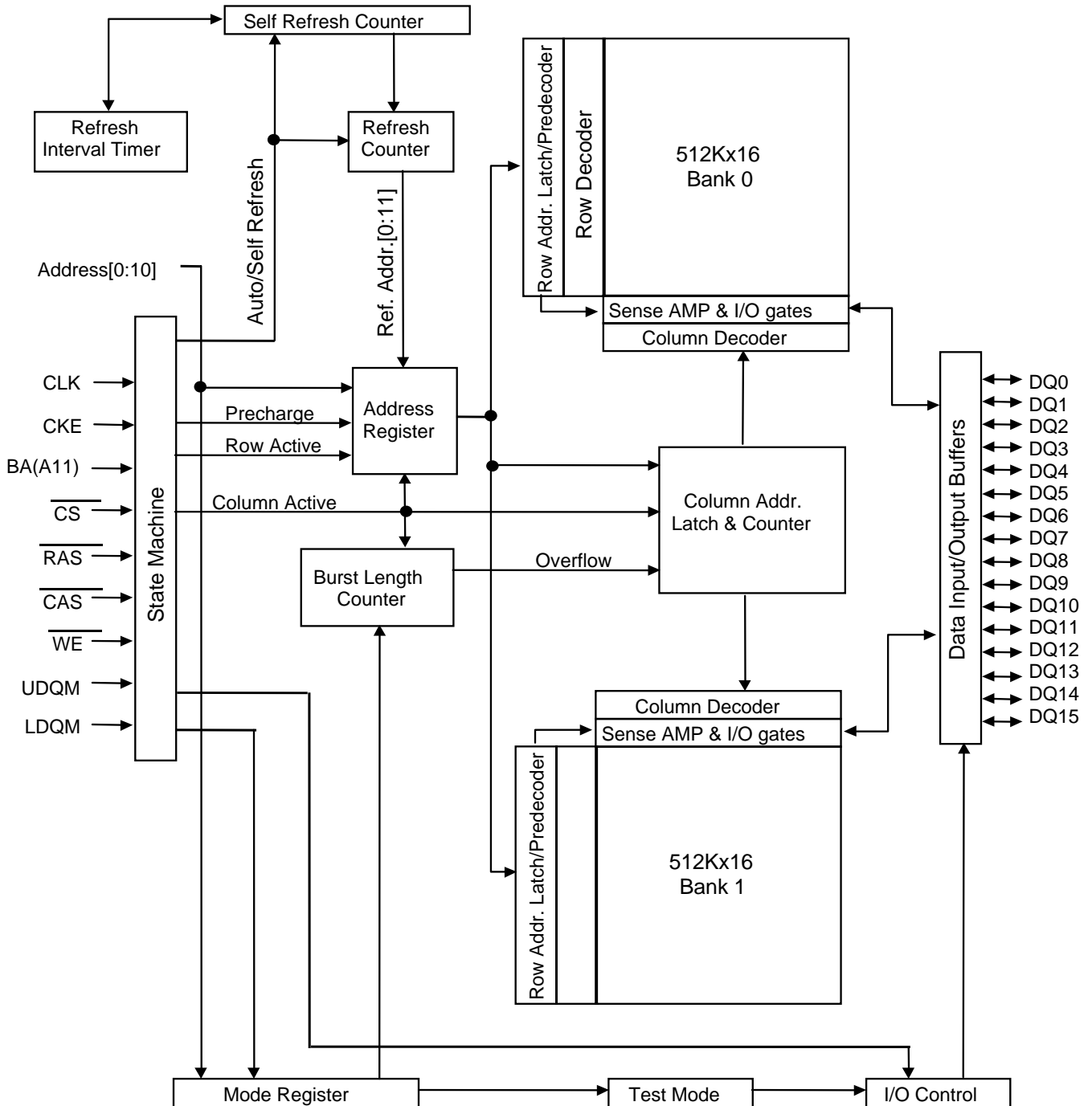



HY57V161610ETP-I

COMMAND TRUTH TABLE

Command	CKEn-1	CKEn	\overline{CS}	\overline{RAS}	\overline{CAS}	\overline{WE}	DQM	A0~A9	A10/AP	BA	Note	
Mode Register Set	H	X	L	L	L	L	X	OP code				
No Operation	H	X	H	X	X	X	X	X				
			L	H	H	H						
Bank Active	H	X	L	L	H	H	X	Row Address		V		
Read	H	X	L	H	L	H	X	Column Address	L	V		
Read with Auto precharge									H			
Write	H	X	L	H	L	L	X	Column Address	L	V		
Write with Auto precharge									H			
Precharge All Bank	H	X	L	L	H	L	X	X	H	X		
Precharge selected Bank									L	V		
Burst Stop	H	X	L	H	H	L	X	X				
U/LDQM	H	X					V	X				
Auto Refresh	H	H	L	L	L	H	X	X				
Burst-READ-Single-WRITE	H	X	L	L	L	L	X	A9 Pin High (Other Pins OP code)				
Self Refresh ¹	Entry	H	L	L	L	L	H	X	X			
	Exit	L	H	H	H	H	X					
Precharge power down	Entry	H	L	H	X	X	X	X	X			
				L	H	H	H					
	Exit	L	H	H	X	X	X	X				
				L	H	H	H					
Clock Suspend	Entry	H	L	H	X	X	X	X	X			
				L	V	V	V					
	Exit	L	H	X				X				

Note :

1. Exiting Self Refresh occurs by asynchronously bringing CKE from low to high.
2. X=Do not care, L=Low, H=High, BA=Bank Address, RA= Row Address, CA=Column Address, Opcode=Operand Code, NOP=No Operation.



HY57V161610E

2 Banks x 512K x 16 Bit Synchronous DRAM

DESCRIPTION

THE Hynix HY57V161610E is a 16,777,216-bits CMOS Synchronous DRAM, ideally suited for the main memory and graphic applications which require large memory density and high bandwidth. HY57V161610E is organized as 2banks of 524,288x16.

HY57V161610E is offering fully synchronous operation referenced to a positive edge clock. All inputs and outputs are synchronized with the rising edge of the clock input. The data paths are internally pipelined to achieve very high bandwidth. All input and output voltage levels are compatible with LVTTTL.

Programmable options include the length of pipeline (Read latency of 1,2 or 3), the number of consecutive read or write cycles initiated by a single control command (Burst length of 1,2,4,8 or full page), and the burst count sequence(sequential or interleave). A burst of read or write cycles in progress can be terminated by a burst terminate command or can be interrupted and replaced by a new burst read or write command on any cycle. (This pipeline design is not restricted by a `2N` rule.)

FEATURES

- Single 3.0V to 3.6V power supply
- All device pins are compatible with LVTTTL interface
- JEDEC standard 400mil 50pin TSOP-II with 0.8mm of pin pitch
- All inputs and outputs referenced to positive edge of system clock
- Data mask function by UDQM/LDQM
- Internal two banks operation
- Auto refresh and self refresh
- 4096 refresh cycles / 64ms
- Programmable Burst Length and Burst Type
 - 1, 2, 4, 8 and Full Page for Sequence Burst
 - 1, 2, 4 and 8 for Interleave Burst
- Programmable $\overline{\text{CAS}}$ Latency ; 1, 2, 3 Clocks

ORDERING INFORMATION

Part No.	Clock Frequency	Organization	Interface	Package
HY57V161610ET-5	200MHz	2Banks x 512Kbits x 16	LVTTTL	400mil 50pin TSOP II
HY57V161610ET-55	183MHz			
HY57V161610ET-6	166MHz			
HY57V161610ET-7	143MHz			
HY57V161610ET-8	125MHz			
HY57V161610ET-10	100MHz			
HY57V161610ET-15	66MHz			

Note :

1. VDD(min) of HY57V161610ET-5/55 is 3.15V

This document is a general product description and is subject to change without notice. Hynix Semiconductor does not assume any responsibility for use of circuits described. No patent licenses are implied

Rev. 0.2 / Aug. 2003

1



HY57V161610E

PIN CONFIGURATION

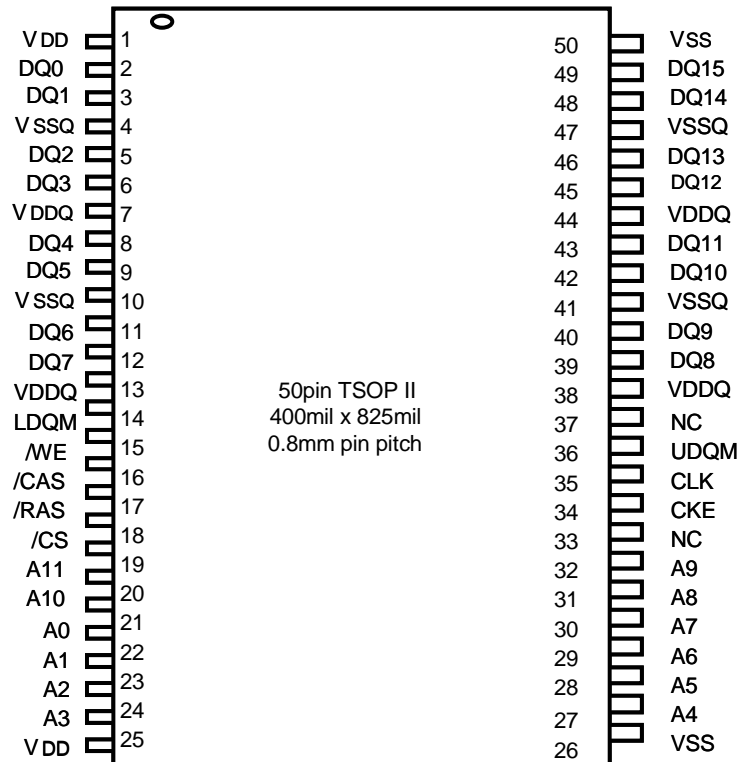

PIN DESCRIPTION

PIN	PIN NAME	DESCRIPTION
CLK	Clock	The system clock input. All other inputs are referenced to the SDRAM on the rising edge of CLK.
CKE	Clock Enable	Controls internal clock signal and when deactivated, the SDRAM will be one of the states among power down, suspend or self refresh.
$\overline{\text{CS}}$	Chip Select	Command input enable or mask except CLK, CKE and DQM
BA	Bank Address	Select either one of banks during both $\overline{\text{RAS}}$ and $\overline{\text{CAS}}$ activity.
A0 ~ A10	Address	Row Address : RA0 ~ RA10, Column Address : CA0 ~ CA7 Auto-precharge flag : A10
$\overline{\text{RAS}}$, $\overline{\text{CAS}}$, $\overline{\text{WE}}$	Row Address Strobe, Column Address Strobe, Write Enable	$\overline{\text{RAS}}$, $\overline{\text{CAS}}$ and $\overline{\text{WE}}$ define the operation. Refer function truth table for details
LDQM, UDQM	Data Input/Output Mask	DQM control output buffer in read mode and mask input data in write mode
DQ0 ~ DQ15	Data Input/Output	Multiplexed data input / output pin
VDD/VSS	Power Supply/Ground	Power supply for internal circuit and input buffer
VDDQ/VSSQ	Data Output Power/Ground	Power supply for DQ
NC	No Connection	No connection



HY57V161610E

FUNCTIONAL BLOCK DIAGRAM

1Mx16 Synchronous DRAM

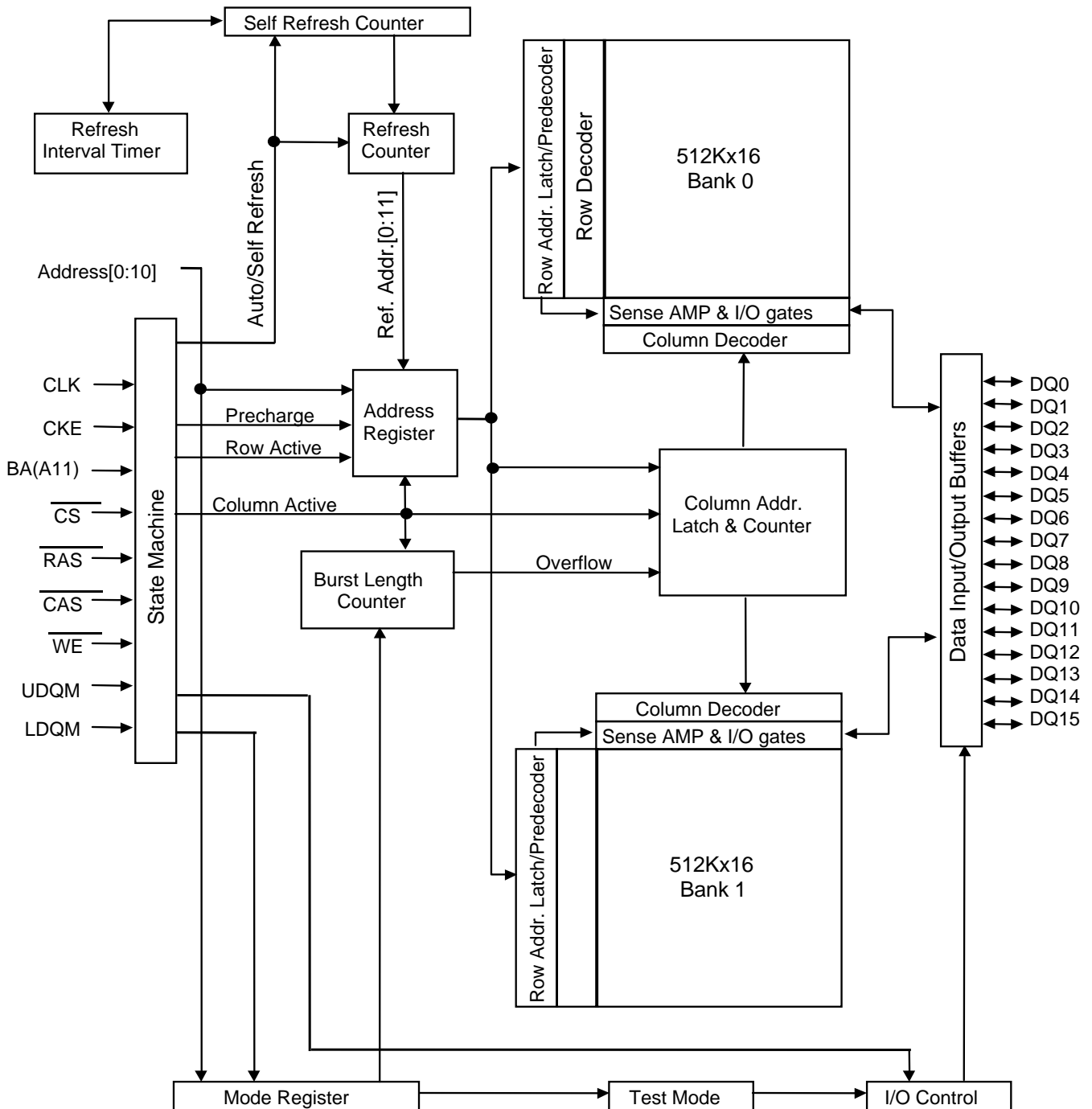



HY57V161610E

COMMAND TRUTH TABLE

Command	CKEn-1	CKEn	\overline{CS}	\overline{RAS}	\overline{CAS}	\overline{WE}	DQM	A0~A9	A10/AP	BA	Note	
Mode Register Set	H	X	L	L	L	L	X	OP code				
No Operation	H	X	H	X	X	X	X	X				
			L	H	H	H						
Bank Active	H	X	L	L	H	H	X	Row Address		V		
Read	H	X	L	H	L	H	X	Column Address	L	V		
Read with Auto precharge									H			
Write	H	X	L	H	L	L	X	Column Address	L	V		
Write with Auto precharge									H			
Precharge All Bank	H	X	L	L	H	L	X	X	H	X		
Precharge selected Bank									L	V		
Burst Stop	H	X	L	H	H	L	X	X				
U/LDQM	H	X					V	X				
Auto Refresh	H	H	L	L	L	H	X	X				
Burst-READ-Single-WRITE	H	X	L	L	L	L	X	A9 Pin High (Other Pins OP code)				
Self Refresh ¹	Entry	H	L	L	L	L	H	X	X			
	Exit	L	H	H	X	X	X	X				
Precharge power down	Entry	H	L	H	X	X	X	X	X			
				L	H	H	H					
	Exit	L	H	H	X	X	X	X				
				L	H	H	H					
Clock Suspend	Entry	H	L	H	X	X	X	X	X			
				L	V	V	V					
	Exit	L	H	X				X				

Note :

1. Exiting Self Refresh occurs by asynchronously bringing CKE from low to high.
2. X=Do not care, L=Low, H=High, BA=Bank Address, RA= Row Address, CA=Column Address, Opcode=Operand Code, NOP=No Operation.



2-CHANNEL ELECTRONIC VOLUME

■ GENERAL DESCRIPTION

NJW1159 is a two channel electronic volume IC. It is included output buffer amplifier and also resistor output terminal for using external amplifier to customize for your application. These functions are controlled by three-wired serial data. And the chip selector is available for using four chips on same serial bus line. It's available for two-channel stereo and or multi-channel audio volume.

■ PACKAGE OUTLINE



NJW1159V

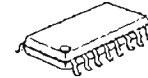

NJW1159M

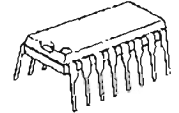

NJW1159D

■ FEATURES

- Operating Voltage
- Three-Wired Serial Data Control
- Chip Selector
- Volume
- Bi-CMOS Technology
- Package Outline

± 4.5 to ± 7.5 V

available for using four chips on same serial bus line.
0 to -95dB/1dBstep, MUTE

SSOP16, DMP16, DIP16

■ BLOCK DIAGRAM

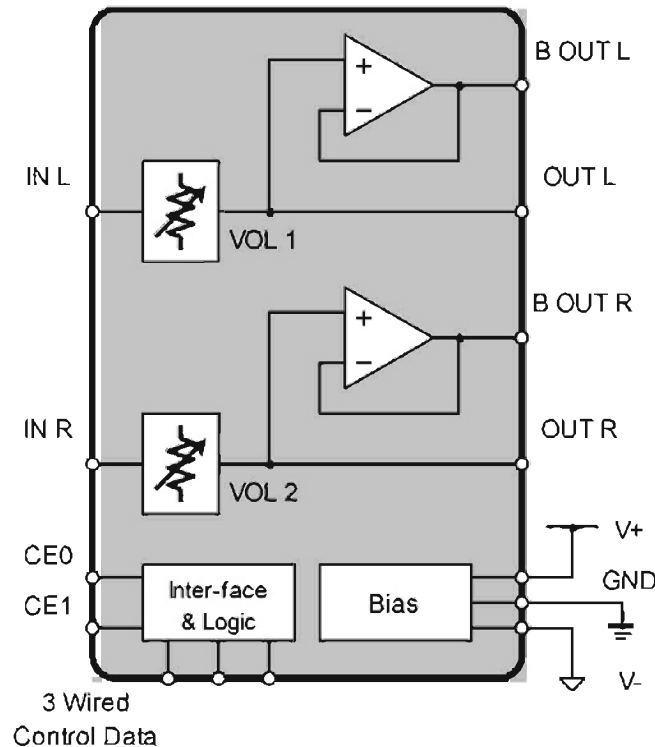

CMOS 16-Bit Microcontrollers

T5CC1

1. Outline and Features

T5CC1 is a high-speed 16-bit microcontroller designed for the control of various mid- to large-scale equipment.

T5CC1 comes in a 100-pin flat package.

Listed below are the features.

(1) High-speed 16-bit CPU (900/L1 CPU)

- Instruction mnemonics are upward-compatible with TLCS-90/900
- General-purpose registers and register banks
- 16 Mbytes of linear address space
- 16-bit multiplication and division instructions; bit transfer and arithmetic instructions
- Micro DMA: 4-channels (593 ns/2 bytes at 27 MHz)

(2) Minimum instruction execution time: 148 ns (at 27 MHz)

(3) Built-in RAM: 16 Kbytes

Built-in ROM: 256 Kbytes Flash memory

4 Kbytes mask ROM (used for booting)

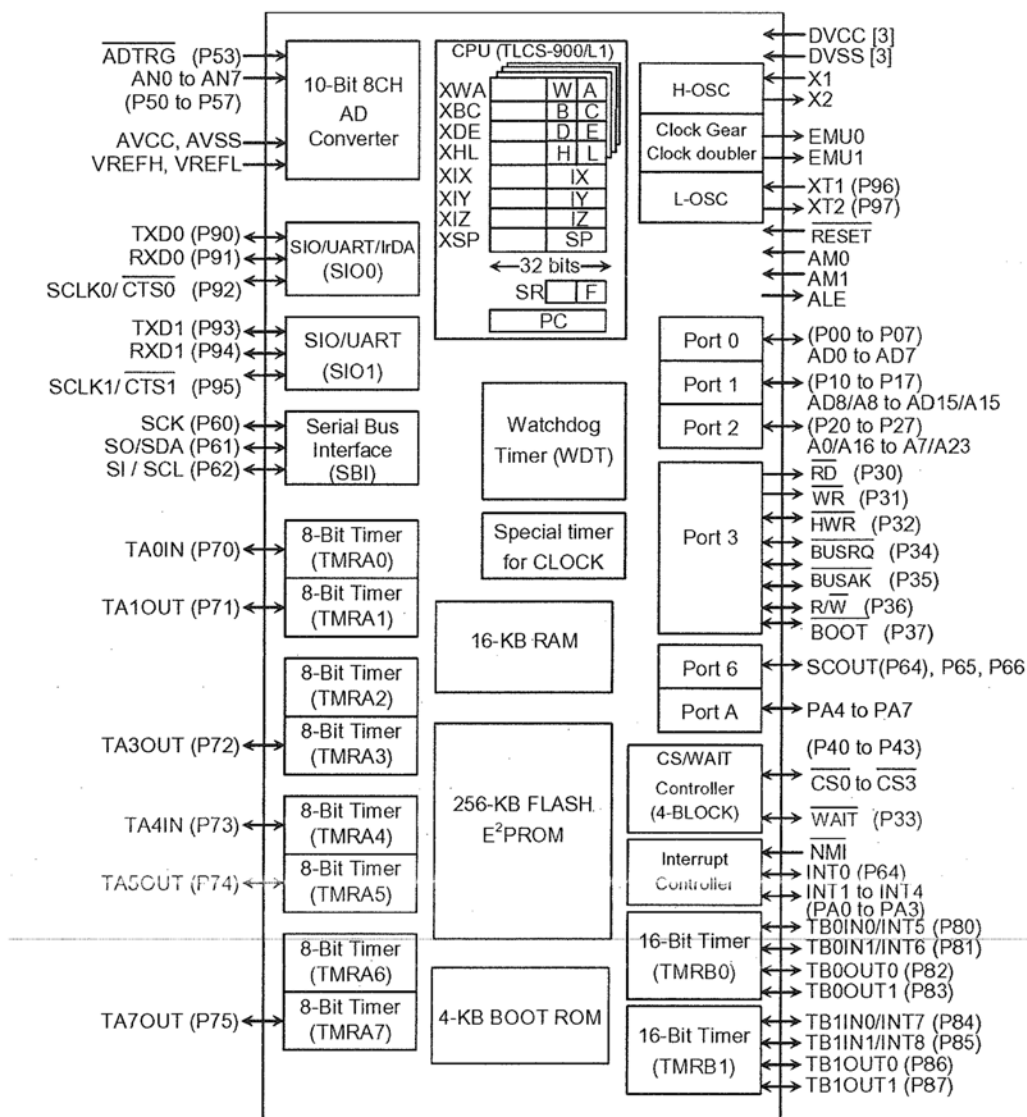

TOSHIBA

T5CC1

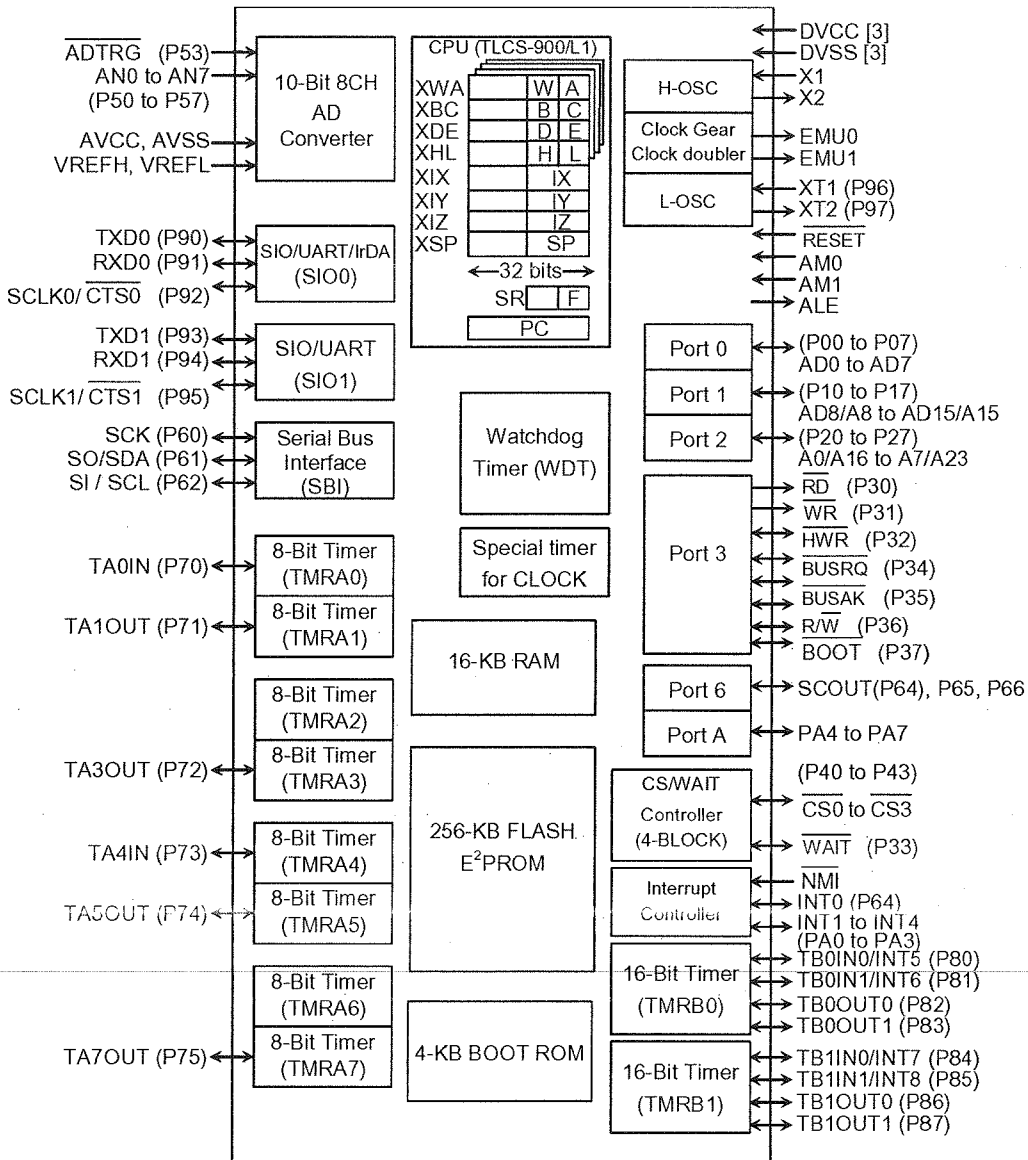

(): Initial function after reset

Figure 1.1 T5CC1 Block Diagram

2. Pin Assignment and Pin Functions

The assignment of input/output pins for the T5CC1, their names and functions are as follows:

2.1 Pin Assignment Diagram

Figure 2.1.1 shows the pin assignment of the T5CC1.

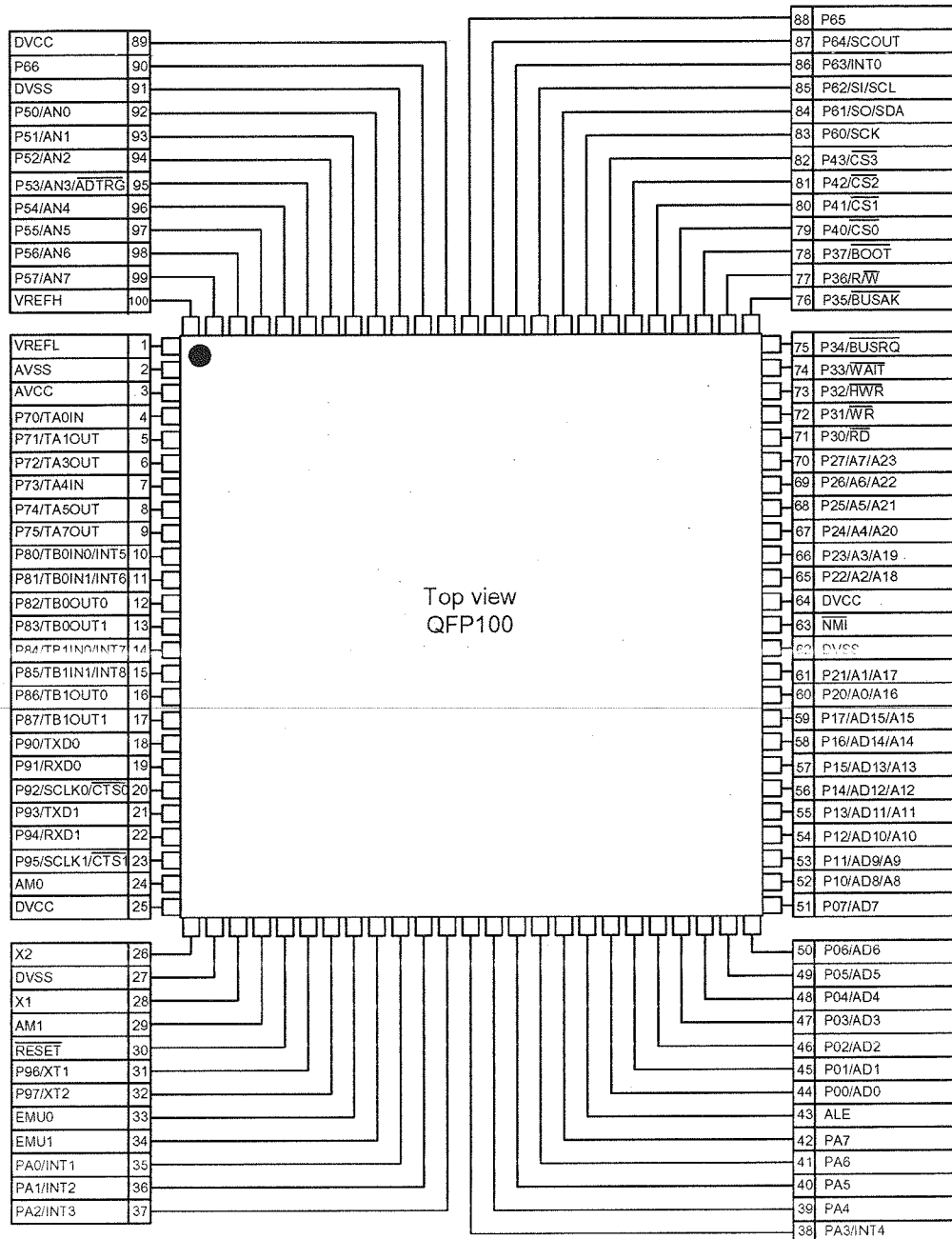

Figure 2.1.1 Pin assignment diagram (100-pin LQFP)

TOSHIBA

T5CC1

2.2 Pin Names and Functions

The names of the input/output pins and their functions are described below.

Table 2.2.1 Pin names and functions.

Table 2.2.1 Pin names and functions (1/3)

Pin Name	Number of Pins	I/O	Functions
P00~P07 AD0~AD7	8	I/O I/O	Port 0: I/O port that allows I/O to be selected at the bit level Address and data (lower): Bits 0 to 7 of address and data bus
P10~P17 AD8~AD15 A8~A15	8	I/O I/O Output	Port 1: I/O port that allows I/O to be selected at the bit level Address and data (upper): Bits 8 to 15 for address and data bus Address: Bits 8 to 15 of address bus
P20~P27 A0~A7 A16~A23	8	I/O Output Output	Port 2: I/O port that allows I/O to be selected at the bit level Address: Bits 0 to 7 of address bus Address: Bits 16 to 23 of address bus
P30 \overline{RD}	1	Output Output	Port 30: Output port Read: Strobe signal for reading external memory This port output RD signal also case of reading internal-area by setting P3 <P30> = 0 and P3FC <P30F> = 1.
P31 \overline{WR}	1	Output Output	Port 31: Output port Write: Strobe signal for writing data to pins AD0 to AD7
P32 \overline{HWR}	1	I/O Output	Port 32: I/O port (with pull-up resistor) High Write: Strobe signal for writing data to pins AD8 to AD15
P33 \overline{WAIT}	1	I/O Input	Port 33: I/O port (with pull-up resistor) Wait: Pin used to request CPU bus wait ((1+N) WAIT mode)
P34 BUSRQ	1	I/O Input	Port 34: I/O port (with pull-up resistor) Bus Request: Signal used to request Bus Release
P35 \overline{BUSAK}	1	I/O Output	Port 35: I/O port (with pull-up resistor) Bus Acknowledge: Signal used to acknowledge Bus Release
P36 R/ \overline{W}	1	I/O Output	Port 36: I/O port (with pull-up resistor) Read/Write: 1 represents Read or Dummy cycle; 0 represents Write cycle.
P37 \overline{BOOT}	1	I/O Input	Port 36: I/O port (with pull-up resistor) This pin sets single boot mode. When released reset, Single boot mode is started at P37 = Low level.
P40 $\overline{CS0}$	1	I/O Output	Port 40: I/O port (with pull-up resistor) Chip Select 0: Outputs 0 when address is within specified address area
P41 $\overline{CS1}$	1	I/O Output	Port 41: I/O port (with pull-up resistor) Chip Select 1: Outputs 0 if address is within specified address area
P42 $\overline{CS2}$	1	I/O Output	Port 42: I/O port (with pull-up resistor) Chip Select 2: Outputs 0 if address is within specified address area
P43 $\overline{CS3}$	1	I/O Output	Port 43: I/O port (with pull-up resistor) Chip Select 3: Outputs 0 if address is within specified address area
P50~P57 AN0~AN7 \overline{ADTRG}	8	Input Input Input	Port 5: Pin used to input port Analog input: Pin used to input to AD converter AD Trigger: Signal used to request start of AD converter (Shared with 53 pin)

TOSHIBA

T5CC1

Table 2.2.1 Pin names and functions (2/3)

Pin Name	Number of Pins	I/O	Functions
P60 SCK	1	I/O I/O	Port 60: I/O port Serial bus interface clock in SIO Mode
P61 SO SDA	1	I/O Output I/O	Port 61: I/O port Serial bus interface send data at SIO mode Serial bus interface send/recv data at I ² C bus mode Open-drain output mode by programmable
P62 SI SCL	1	I/O Input I/O	Port 62: I/O port Serial bus interface receive data at SIO mode Serial bus interface clock I/O data at I ² C bus mode Open-drain output mode by programmable
P63 INT0	1	I/O Input	Port 63: I/O port Interrupt Request Pin 0: Interrupt request pin with programmable level / rising edge / falling edge
P64 SCOUT	1	I/O Output	Port 64: I/O port System Clock Output: Outputs f _{PPH} or fs clock.
P65	1	I/O	Port 65 I/O port
P66	1	I/O	Port 66 I/O port
P70 TA0IN	1	I/O Input	Port 70 I/O port 8-bit timer 0 input: Timer 0 input
P71 TA1OUT	1	I/O Output	Port 71 I/O port 8-bit timer 1 output: Timer 0 or Timer 1 output
P72 TA3OUT	1	I/O Output	Port 72 I/O port 8-bit 8-bit timer 3 output: Timer 2 or Timer 3 output
P73 TA4IN	1	I/O Input	Port 73: I/O port 8-bit timer 4 input: Timer 4 input
P74 TA5OUT	1	I/O Output	Port 74: I/O port 8-bit timer 5 output: Timer 4 or Timer 5 output
P75 TA7OUT	1	I/O Output	Port 75: I/O port 8-bit timer 7 output: Timer 6 or Timer 7 output
P80 TB0IN0 INT5	1	I/O Input Input	Port 80: I/O port 16-bit timer 0 input 0: 16-bit Timer 0 count / capture trigger input Interrupt Request Pin 5: Interrupt request pin with programmable rising edge / falling edge.
P81 TB0IN1 INT6	1	I/O Input Input	Port 81: I/O port 16-bit timer 0 input 1: 16-bit Timer 0 count / capture trigger input Interrupt Request Pin 6: Interrupt request on rising edge
P82 TB0OUT0	1	I/O Output	Port 82: I/O port 16-bit timer 0 output 0: 16-bit Timer 0 output
P83 TB0OUT1	1	I/O Output	Port 83: I/O port 16-bit timer 0 output 1: 16-bit Timer 0 output
P84 TB1IN0 INT7	1	I/O Input Input	Port 84: I/O port 16-bit timer 1 input 0: 16-bit Timer 1 count / capture trigger input Interrupt Request Pin 7: Interrupt request pin with programmable rising edge / falling edge.
P85 TB1IN1 INT8	1	I/O Input Input	Port 85: I/O port 16-bit timer 1 input 1: 16-bit Timer 1 count / capture trigger input Interrupt Request Pin 8: Interrupt request on rising edge
P86 TB1OUT0	1	I/O Output	Port 86: I/O port 16-bit timer 1 output 0: 16-bit Timer 1 output 16-bit
P87 TB1OUT1	1	I/O Output	Port 87: I/O port 16-bit timer 1 output 1: 16-bit Timer 1 output 16-bit

TOSHIBA

T5CC1

Table 2.2.1 Pin names and functions (3/3)

Pin Name	Number of Pins	I/O	Functions
P90 TXD0	1	I/O Output	Port 90: I/O port Serial Send Data 0 (programmable open-drain)
P91 RXD0	1	I/O Input	Port 91: I/O port Serial Receive Data 0
P92 SCLK0 CTS0	1	I/O I/O Input	Port 92: I/O port Serial Clock I/O 0 Serial Data Send Enable 0 (Clear to Send)
P93 TXD1	1	I/O Output	Port 93: I/O port Serial Send Data 1 (programmable open-drain)
P94 RXD1	1	I/O Input	Port 94: I/O port (with pull-up resistor) Serial Receive Data 1
P95 SCLK1 CTS1	1	I/O I/O Input	Port 95: I/O port (with pull-up resistor) Serial Clock I/O 1 Serial Data Send Enable 1 (Clear to Send)
P96 XT1	1	I/O Input	Port 96: I/O port (open-drain output) Low-frequency oscillator connection pin
P97 XT2	1	I/O Output	Port 97: I/O port (open-drain output) Low-frequency oscillator connection pin
PA0~PA3 INT1~INT4	4	I/O Input	Ports A0 to A3: I/O ports Interrupt Request Pins 1 to 4: Interrupt request pins with programmable rising edge / falling edge.
PA4~PA7	4	I/O	Ports A4 to A7: I/O ports
ALE	1	Output	Address Latch Enable Can be disabled to reduce noise.
$\overline{\text{NMI}}$	1	Input	Non-Maskable Interrupt Request Pin: Interrupt request pin with programmable falling edge or both edge.
AM0~1	2	Input	Operation mode: Fixed to AM1 = 1, AM0 = 1
EMU0	1	Output	Open pin
EMU1	1	Output	Open pin
$\overline{\text{RESET}}$	1	Input	Reset: initializes T5CC1. (With pull-up resistor)
VREFH	1	Input	Pin for reference voltage input to AD converter (H)
VREFL	1	Input	Pin for reference voltage input to AD converter (L)
AVCC	1		Power supply pin for AD converter
AVSS	1		GND pin for AD converter (0 V)
X1/X2	2	I/O	High-frequency oscillator connection pins
DVCC	3		Power supply pins (All DVCC pins should be connected with the power supply pin.)
DVSS	3		GND pins (0 V) (All DVSS pins should be connected with the power supply pin.)

Note: An external DMA controller cannot access the device's built-in memory or built-in I/O devices using the $\overline{\text{BUSRQ}}$ and $\overline{\text{BUSAk}}$ signal.

NJW1159

■ PIN ASSIGNMENT

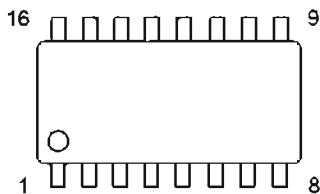

No.	Symbol	Function
1	OUTL	Lch External Opamp Input Connection Terminal
2	BOUTL	Lch Output
3	VDD_OUT	Internal VDD Noise Rejection Capacitor Terminal
4	BOUTr	Rch Output
5	OUTr	Rch External Opamp Input Connection Terminal
6	VSS_OUT	Internal VSS Noise Rejection Capacitor Terminal
7	V+	+ Power supply voltage input
8	V-	- Power supply voltage input
9	INL	Lch Input
10	INR	Rch Input
11	CE0	Chip Enable Terminal 0
12	CE1	Chip Enable Terminal 1
13	DATA	Control data signal input
14	CLOCK	Clock signal input
15	LACTH	Latch signal input
16	GND	Ground

■ ABSOLUTE MAXIMUM RATING (Ta=25°C)

PARAMETER	SYMBOL	RATING	UNIT
Power Supply Voltage	V^+ / V^-	+8/-8	V
Maximum Input Voltage	V_{IM}	$V^+ / V^{(-)}$	V
Power Dissipation	P_D	SSOP16 ; 300 DMP16 ; 300 DIP16 ; 500	mW
Operating Temperature Range	T_{opr}	-40 to +85	°C
Storage Temperature Range	T_{stg}	-40 to +125	°C

(*) For the maximum input voltage less than V^+ / V^-

■ ELECTRICAL CHARACTERISTICS (Ta=25°C, $V^+ / V^- = +7V / -7V$, $R_L = 47k\Omega$)

PARAMETER	SYMBOL	TEST CONDITION	MIN.	TYP.	MAX.	UNIT
◆ Power Supply						
Operating Voltage 1	V+		4.5	7.0	7.5	V
Operating Voltage 2	V-		-7.5	-7.0	-4.5	V
Supply Current 1	I_{CC}	No signal	-	4.5	9.0	mA
Supply Current 2	I_{EE}	No signal	-	4.5	9.0	mA
◆ Input/Output Characteristics (BOUTr : 2pin, BOUTr : 4pin)						
Maximum Output Voltage	V_{OM}	f=1kHz, THD=1% Volume=0dB	3.0	4.0	-	Vrms
Voltage Gain	G_V	$V_{IN}=1V_{rms}$, f=1kHz Volume=0dB	-0.5	0	0.5	dB
Channel Gain Balance 1	ΔG_{V1}	$V_{IN}=1V_{rms}$, f=1kHz Volume=0dB	-0.5	0	0.5	dB
Channel Gain Balance 2	ΔG_{V2}	$V_{IN}=1V_{rms}$, f=1kHz Volume=-60dB	-1.0	0	1.0	dB
Maximum Attenuation	A_{TT}	$V_{IN}=1V_{rms}$, f=1kHz Volume=-95dB, A-weight	-	-95	-	dB
Mute Level	Mute	$V_{IN}=1V_{rms}$, f=1kHz Volume=Mute, A-weight	-	-110	-	dB
Output Noise Voltage	V_{NO}	Volume=0dB, $R_g=0\Omega$, A-weight	-	-105 (5.6 μ)	-95 (17.8 μ)	dBV (Vrms)
Total Harmonic Distortion	THD	$V_o=1V_{rms}$, f=1kHz, Volume=0dB, BW=400-30kHz	-	0.005	0.05	%
Channel Separation	CS	$V_o=1V_{rms}$, f=1kHz, A-weight Volume=0dB, $R_g=0\Omega$	-	-100	-90	dB



HCF4053B

TRIPLE 2-CHANNEL ANALOG MULTIPLEXER/DEMULTIPLEXER

- LOW "ON" RESISTANCE : 125Ω (Typ.)
OVER 15V p.p SIGNAL-INPUT RANGE FOR
 $V_{DD} - V_{EE} = 15V$
- HIGH "OFF" RESISTANCE : CHANNEL
LEAKAGE $\pm 100pA$ (Typ.) at $V_{DD} - V_{EE} = 18V$
- BINARY ADDRESS DECODING ON CHIP
- HIGH DEGREE OF LINEARITY : < 0.5%
DISTORTION TYP. at $f_{IS} = 1KHz$, $V_{IS} = 5 V_{pp}$,
 $V_{DD} - V_{SS} \geq 10V$, $R_L = 10K\Omega$
- VERY LOW QUIESCENT POWER
DISSIPATION UNDER ALL DIGITAL
CONTROL INPUT AND SUPPLY
CONDITIONS : 0.2 μW (Typ.)
at $V_{DD} - V_{SS} = V_{DD} - V_{EE} = 10V$
- MATCHED SWITCH CHARACTERISTICS :
 $R_{ON} = 5\Omega$ (Typ.) FOR $V_{DD} - V_{EE} = 15V$
- WIDE RANGE OF DIGITAL AND ANALOG
SIGNAL LEVELS : DIGITAL 3 to 20,
ANALOG TO 20V p.p.
- QUIESCENT CURRENT SPECIF. UP TO 20V
- 5V, 10V AND 15V PARAMETRIC RATINGS
- INPUT LEAKAGE CURRENT
 $I_l = 100nA$ (MAX) AT $V_{DD} = 18V$ $T_A = 25^\circ C$
- 100% TESTED FOR QUIESCENT CURRENT
- MEETS ALL REQUIREMENTS OF JEDEC
JESD13B " STANDARD SPECIFICATIONS
FOR DESCRIPTION OF B SERIES CMOS
DEVICES"

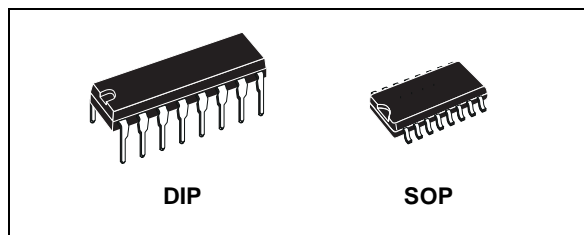

ORDER CODES

PACKAGE	TUBE	T & R
DIP	HCF4053BEY	
SOP	HCF4053BM1	HCF4053M013TR

technology available in DIP and SOP packages. The HCF4053B analog multiplexer/demultiplexer is a digitally controlled analog switch having low ON impedance and very low OFF leakage current. This multiplexer circuit dissipate extremely low quiescent power over the full $V_{DD} - V_{SS}$ and $V_{DD} - V_{EE}$ supply voltage range, independent of the logic state of the control signals.

When a logic "1" is present at the inhibit input terminal all channel are off. This device is a triple 2-channel multiplexer having three separate digital control inputs, A, B, and C, and an inhibit input. Each control input selects one of a pair of channels which are connected in a single pole double-throw configuration.

DESCRIPTION

The HCF4053B is a monolithic integrated circuit fabricated in Metal Oxide Semiconductor

PIN CONNECTION

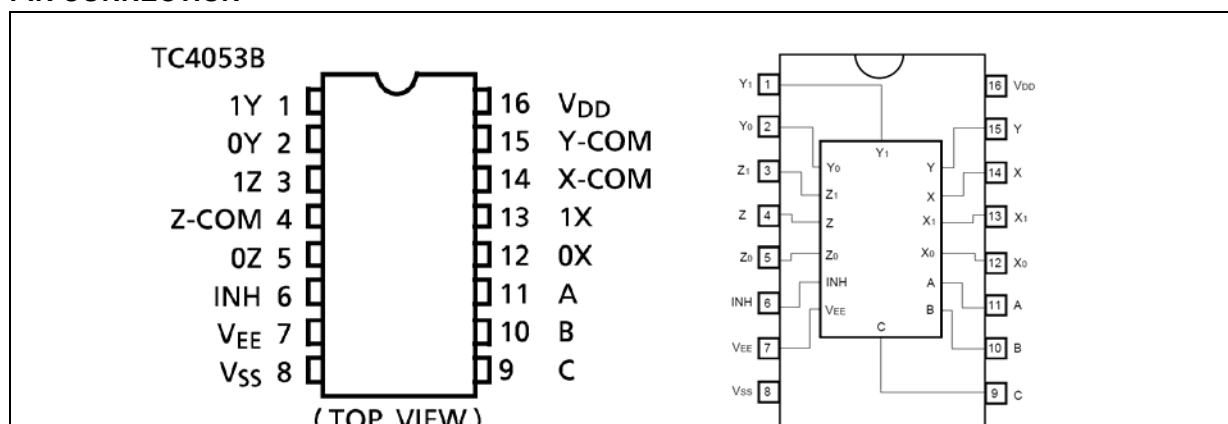

October 2002

HCF4053B

INPUT EQUIVALENT CIRCUIT

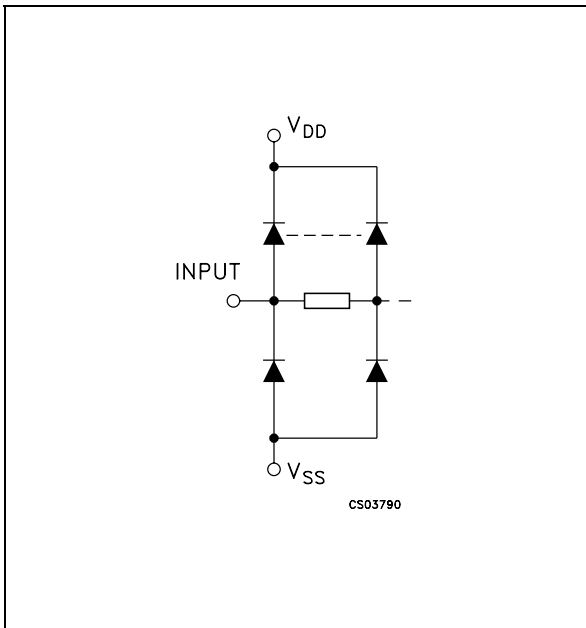

PIN DESCRIPTION

PIN No	SYMBOL	NAME AND FUNCTION
11, 10, 9	A, B, C	Binary Control Inputs
6	INH	Inhibit Inputs
12, 13, 2, 1, 5, 3	IN/OUT	ax,ay,bx,by,cx,cy Input/Output
14	OUT/IN	ax or ay
15	OUT/IN	bx or by
4	OUT/IN	cx or cy
7	V _{EE}	Supply Voltage
8	V _{SS}	Negative Supply Voltage
16	V _{DD}	Positive Supply Voltage

TRUTH TABLE

INHIBIT	C or B or A	
0	0	ax or bx or cx
0	1	ay or by or cy
1	X	NONE

X : Don't Care

FUNCTIONAL DIAGRAM

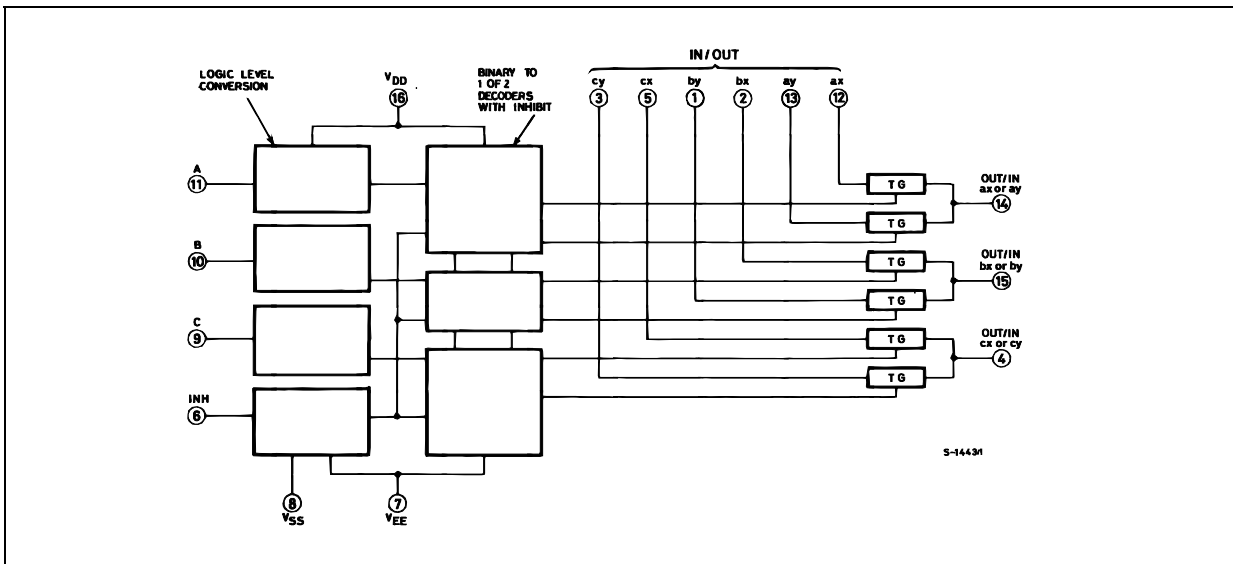



NJM2595

5-INPUT 3-OUTPUT VIDEO SWITCH

■ GENERAL DESCRIPTION

The **NJM2595** is a 5-input 3-output video switch. Its switches select one from five signals received from VTR,TV,DVD, TV-GAME and others.

The NJM2595 is designed for audio items, such as AV amplifier and others.

■ PACKAGE OUTLINE

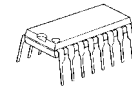

NJM2595D

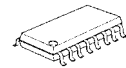

NJM2595M

■ FEATURES

- 5-input 3-output
- Operating Voltage ± 4.0 to $\pm 6.5V$
- Operating current $\pm 15mA$ typ. at $V_{cc}=\pm 5V$
- Crosstalk $-65dB$ typ.
- Internal 6dB Amplifier
- Internal 75Ω Driver
- Bipolar Technology
- Package Outline DIP16,DMP16

■ PIN CONFIGURATION and BLOCK DIAGRAM

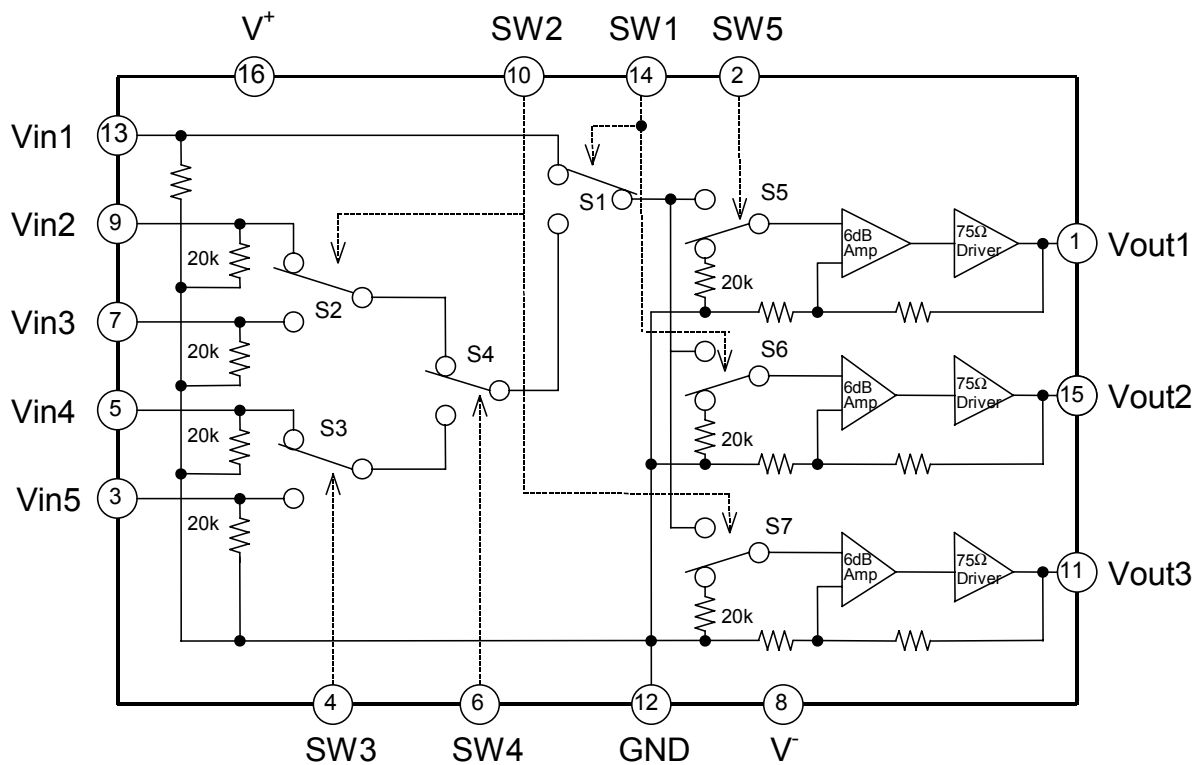

NJM2595

■ EQUIVALENT CIRCUIT

PIN No.	PIN NAME	INSIDE EQUIVALENT CIRCUIT	VOLTAGE
16	V ⁺		5V
8	V ⁻		-5V
12	GND		-
13 9 7 5 3	Vin1 Vin2 Vin3 Vin4 Vin5		0V
1 15 11	Vout1 Vout2 Vout3		0V
4 6 2	SW3 SW4 SW5		-

NJM2595

■ EQUIVALENT CIRCUIT

PIN No.	PIN NAME	INSIDE EQUIVALENT CIRCUIT	VOLTAGE
14 10	SW1 SW2		-

■ TEST CIRCUIT

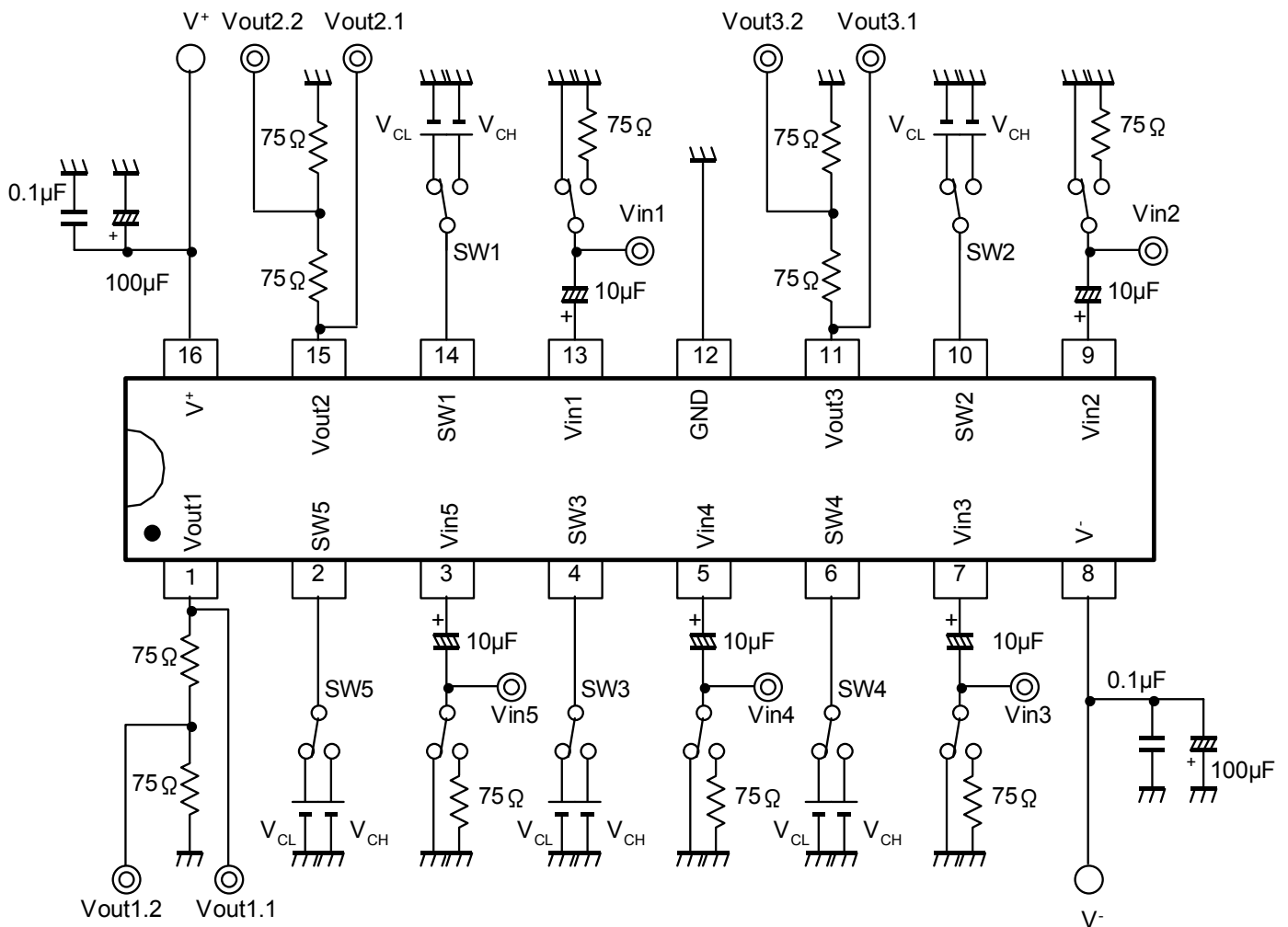

NJM2068M (OP - AMP)



NJM2068

LOW-NOISE DUAL OPERATIONAL AMPLIFIER

■ **GENERAL DESCRIPTION**

The NJM2068 is a high performance, low noise dual operational amplifier. This amplifier features popular pin-out, superior noise performance, and superior total harmonic distortion. This amplifier also features guaranteed noise performance with substantially higher gain-bandwidth product and slew rate which far exceeds that of the 4558 type amplifier. The specially designed low noise input transistors allow the NJM2068 to be used in very low noise signal processing applications such as audio preamplifiers and servo error amplifier.

■ **PACKAGE OUTLINE**

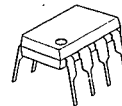

NJM2068D



NJM2068M



NJM2068V

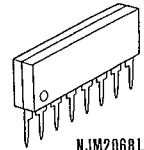

NJM2068L

■ **FEATURES**

- Operating Voltage (±4V ~ ±18V)
- Low Total Harmonic Distortion (0.001% typ.)
- Low Noise Voltage (FLAT+JISA, 0.56 μV typ.)
- High Slew Rate (6V/μs typ.)
- Unity Gain Bandwidth (27MHz @f=10kHz)
- Package Outline DIP8, DMP8, SIP8, SSOP8
- Bipolar Technology

■ **PIN CONFIGURATION**

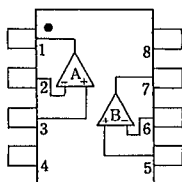

NJM2068D
NJM2068M
NJM2068V

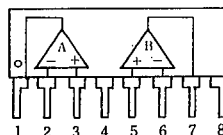

NJM2068L

PIN FUNCTION

1. A OUTPUT
2. A-INPUT
3. A+INPUT
4. V-
5. B+INPUT
6. B-INPUT
7. B OUTPUT
8. V+

■ **EQUIVALENT CIRCUIT (1/2 Shown)**

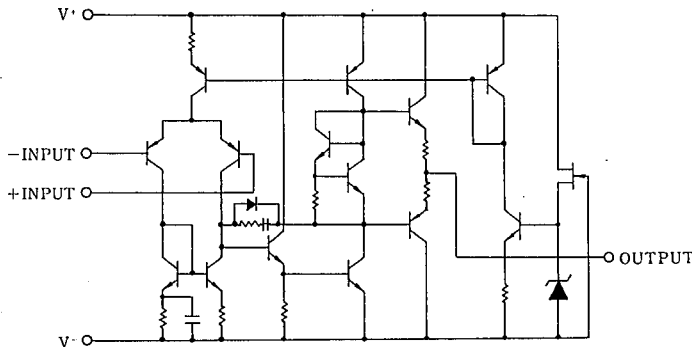



IC86

NJM4556A

DUAL HIGH CURRENT OPERATIONAL AMPLIFIER

■ GENERAL DESCRIPTION

The NJM4556A integrated circuit is a high-gain, high output current dual operational amplifier capable of driving $\pm 70\text{mA}$ into $150\ \Omega$ loads ($\pm 10.5\text{V}$ output voltage), and operating low supply voltage ($V^+/V^- = \pm 2\text{V} \sim$).

The NJM4556A combines many of the fetures of the popular NJM4558 as well as having the capability of driving $150\ \Omega$ loads. In addition, the wide band-width, low noise, high slew rate and low distortion of the NJM4556A make it ideal for many audio, telecommuncations and instrumentation applications.

■ FEATURES

- Operating Voltage ($\pm 2\text{V} \sim \pm 18\text{V}$)
- High Output Current ($I_o = 70\text{mA}$)
- Slew Rate ($3\text{V}/\mu\text{s}$ typ.)
- Gain Band Width Product (8MHz typ.)
- Package Outline DIP8, DMP8, SIP8, SSOP8
- Bipolar Technology

■ PACKAGE OUTLINE

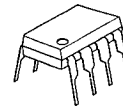

NJM4556AD



NJM4556AM

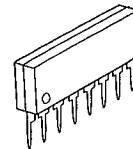

NJM4556AL



NJM4556AV

■ PIN CONFIGURATION

AVR347

harman/kardon

4

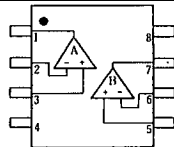

NJM4556AD
NJM4556AM
NJM4556AV

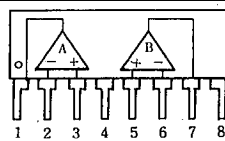

NJM4556AL

PIN FUNCTION

1. A OUTPUT
2. A-INPUT
3. A+INPUT
4. V-
5. B+INPUT
6. B-INPUT
7. B OUTPUT
8. V+

■ EQUIVALENT CIRCUIT (1/2 Shown)

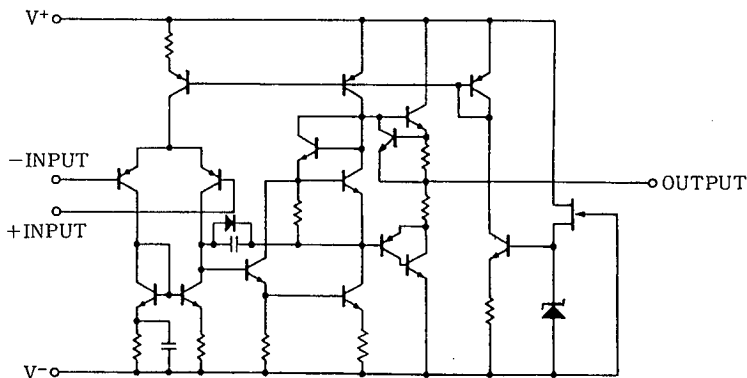

IC87 RE5VL28CATZ IC , RESET

PIN CONFIGURATION

• TO-92

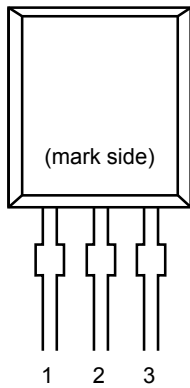

• SOT-89

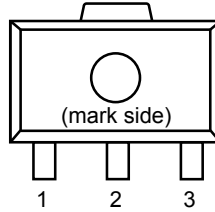

• SOT-23-5

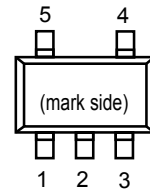

PIN DESCRIPTION

• TO-92

Pin No	Symbol
1	OUT
2	V _{DD}
3	GND

• SOT-89

Pin No	Symbol
1	OUT
2	V _{DD}
3	GND

• SOT-23-5

Pin No	Symbol
1	OUT
2	V _{DD}
3	GND
4	NC
5	NC

BLOCK DIAGRAMS

• Nch Open Drain Output (R>5VL×A)

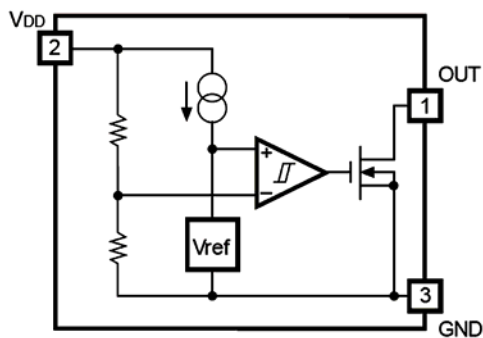

• CMOS Output (R>5VL×C)

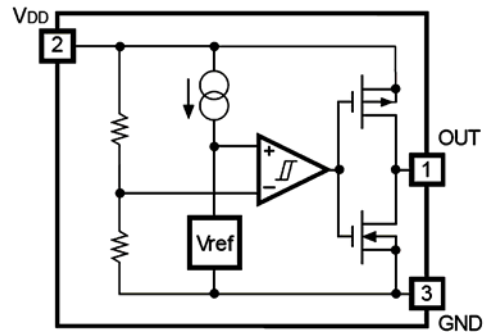



M29W800DT M29W800DB

8 Mbit (1Mb x8 or 512Kb x16, Boot Block)
3V Supply Flash Memory

FEATURES SUMMARY

- SUPPLY VOLTAGE
 - $V_{CC} = 2.7V$ to $3.6V$ for Program, Erase and Read
- ACCESS TIME: 70, 90ns
- PROGRAMMING TIME
 - $10\mu s$ per Byte/Word typical
- 19 MEMORY BLOCKS
 - 1 Boot Block (Top or Bottom Location)
 - 2 Parameter and 16 Main Blocks
- PROGRAM/ERASE CONTROLLER
 - Embedded Byte/Word Program algorithms
- ERASE SUSPEND and RESUME MODES
 - Read and Program another Block during Erase Suspend
- UNLOCK BYPASS PROGRAM COMMAND
 - Faster Production/Batch Programming
- TEMPORARY BLOCK UNPROTECTION MODE
- COMMON FLASH INTERFACE
 - 64 bit Security Code
- LOW POWER CONSUMPTION
 - Standby and Automatic Standby
- 100,000 PROGRAM/ERASE CYCLES per BLOCK
- ELECTRONIC SIGNATURE
 - Manufacturer Code: 0020h
 - Top Device Code M29W800DT: 22D7h
 - Bottom Device Code M29W800DB: 225Bh

Figure 1. Packages

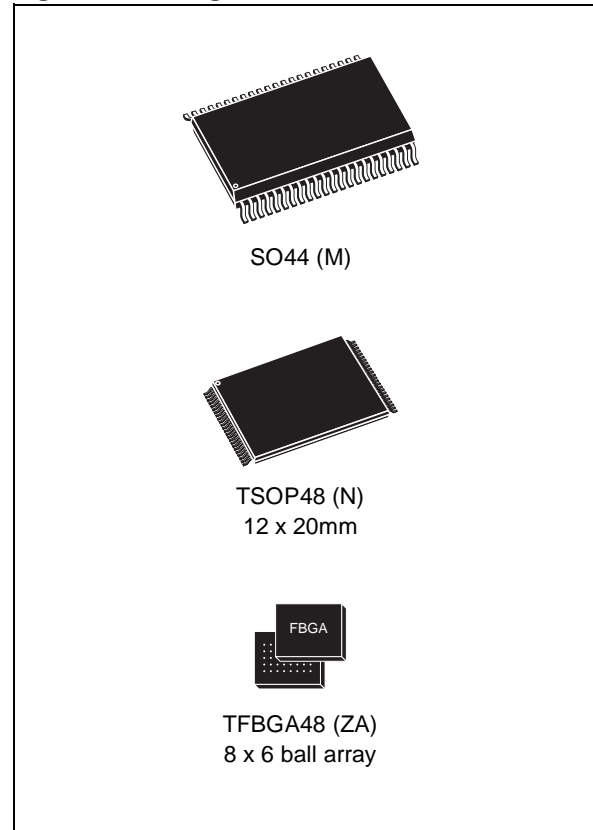

M29W800DT, M29W800DB

Figure 3. SO Connections

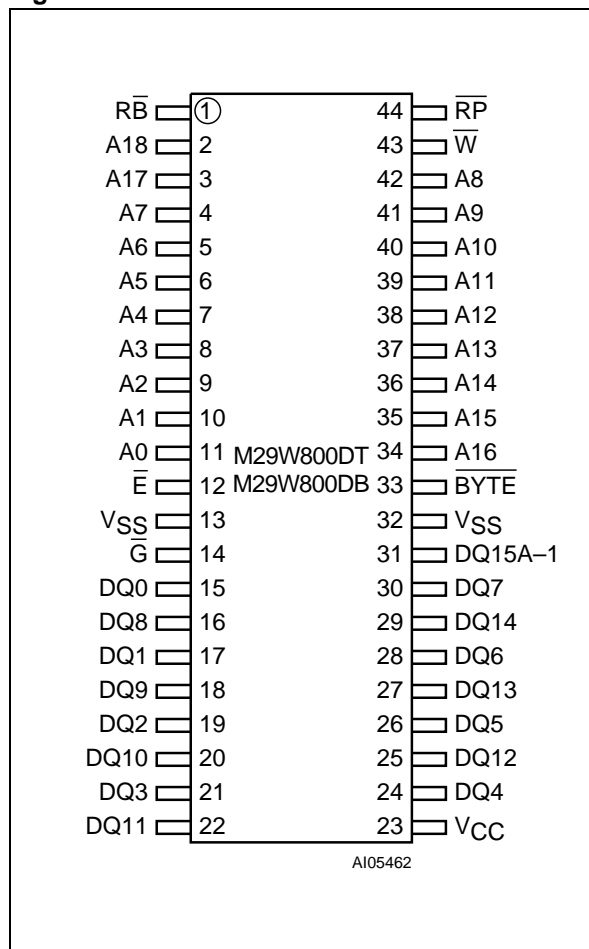
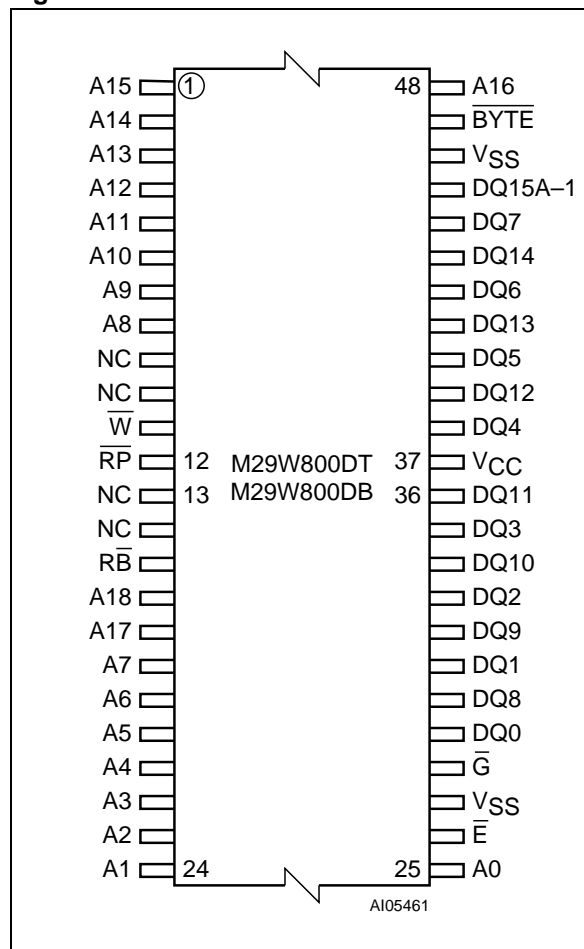

Figure 4. TSOP Connections





74LCX74

LOW VOLTAGE CMOS DUAL D-TYPE FLIP FLOP WITH 5V TOLERANT INPUTS

- 5V TOLERANT INPUTS
- HIGH SPEED :
 $f_{MAX} = 150 \text{ MHz (MAX.) at } V_{CC} = 3V$
- POWER DOWN PROTECTION ON INPUTS AND OUTPUTS
- SYMMETRICAL OUTPUT IMPEDANCE:
 $|I_{OH}| = I_{OL} = 24\text{mA (MIN) at } V_{CC} = 3V$
- PCI BUS LEVELS GUARANTEED AT 24 mA
- BALANCED PROPAGATION DELAYS:
 $t_{PLH} \cong t_{PHL}$
- OPERATING VOLTAGE RANGE:
 $V_{CC(OPR)} = 2.0V \text{ to } 3.6V \text{ (1.5V Data Retention)}$
- PIN AND FUNCTION COMPATIBLE WITH 74 SERIES 74
- LATCH-UP PERFORMANCE EXCEEDS 500mA (JESD 17)
- ESD PERFORMANCE:
 $HBM > 2000V \text{ (MIL STD 883 method 3015);}$
 $MM > 200V$

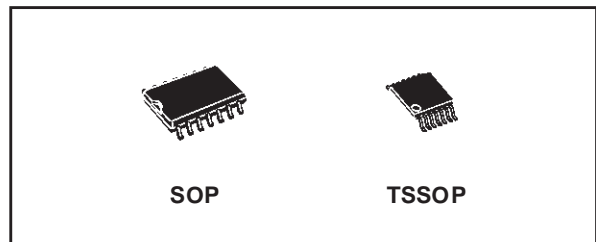

ORDER CODES

PACKAGE	TUBE	T & R
SOP	74LCX74M	74LCX74MTR
TSSOP		74LCX74TTR

DESCRIPTION

The 74LCX74 is a low voltage CMOS DUAL D-TYPE FLIP FLOP WITH PRESET AND CLEAR NON INVERTING fabricated with sub-micron silicon gate and double-layer metal wiring C²MOS technology. It is ideal for low power and high speed 3.3V applications; it can be interfaced to 5V signal environment for inputs.

A signal on the D INPUT is transferred to the Q OUTPUT during the positive going transition of the clock pulse.

CLR and PR are independent of the clock and accomplished by a low setting on the appropriate input.

It has same speed performance at 3.3V than 5V AC/ACT family, combined with a lower power consumption.

All inputs and outputs are equipped with protection circuits against static discharge, giving them 2KV ESD immunity and transient excess voltage.

PIN CONNECTION AND IEC LOGIC SYMBOLS

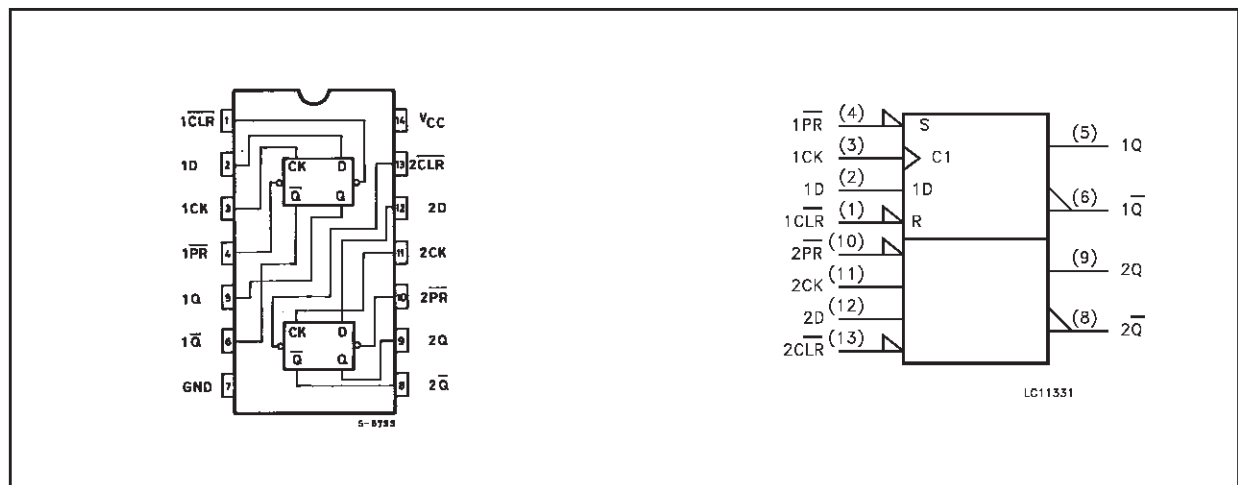

74LCX74

INPUT AND OUTPUT EQUIVALENT CIRCUIT

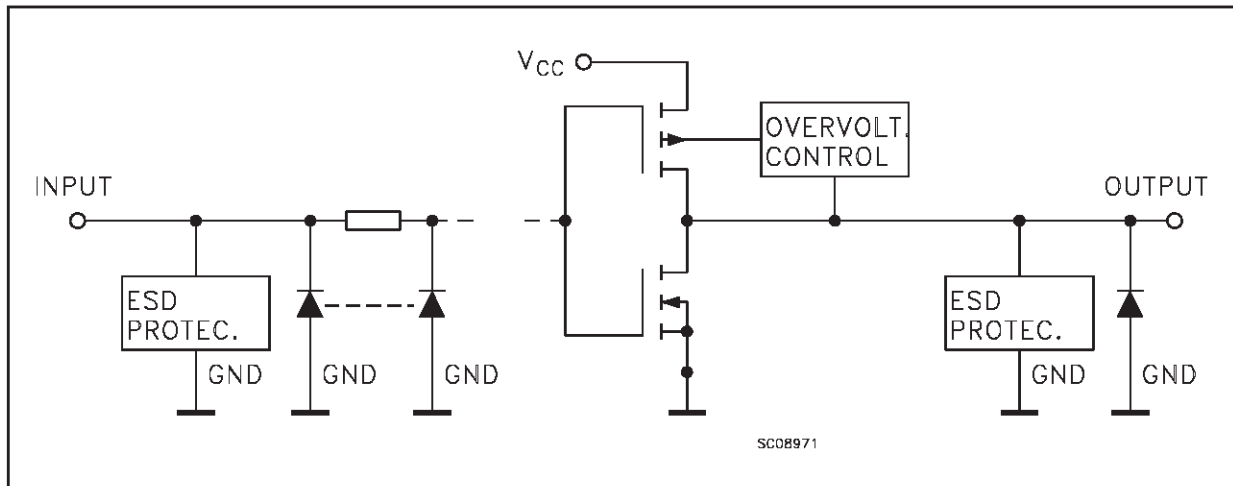

PIN DESCRIPTION

PIN No	SYMBOL	NAME AND FUNCTION
1, 13	1CLR, 2CLR	Asynchronous Reset - Direct Input
2, 12	1D, 2D	Data Inputs
3, 11	1CK, 2CK	Clock Input (LOW to HIGH, Edge Triggered)
4, 10	1PR, 2PR	Asynchronous Set - Direct Input
5, 9	1Q, 2Q	True Flip-Flop Outputs
6, 8	1 \bar{Q} , 2 \bar{Q}	Complement Flip-Flop Outputs
7	GND	Ground (0V)
14	V _{CC}	Positive Supply Voltage

TRUTH TABLE

INPUTS				OUTPUTS		FUNCTION
$\overline{\text{CLR}}$	$\overline{\text{PR}}$	D	CK	Q	\bar{Q}	
L	H	X	X	L	H	CLEAR
H	L	X	X	H	L	PRESET
L	L	X	X	H	H	
H	H	L		L	H	
H	H	H		H	L	
H	H	X		Q _n	\bar{Q}_n	NO CHANGE

X : Don't Care



Multiformat 11-Bit HDTV Video Encoder

Preliminary Technical Data

ADV7322

FEATURES

High definition input formats

16-, 24-bit (4:2:2, 4:4:4) parallel YCrCb

Fully compliant with

SMPTE 274M (1080i, 1080p @ 74.25 MHz)

SMPTE 296M (720p)

SMPTE 240M (1035i)

RGB in 3- × 8-bit 4:4:4 input format

HDTV RGB supported

RGB, RGBHV

Other high definition formats using async timing mode

Enhanced definition input formats

8-, 16-, 24-bit (4:2:2, 4:4:4) parallel YCrCb

SMPTE 293M (525p)

BTA T-1004 EDTV2 (525p)

ITU-R BT.1358 (625p/525p)

ITU-R BT.1362 (625p/525p)

RGB in 3- × 8-bit 4:4:4 input format

Standard definition input formats

CCIR-656 4:2:2 8-bit or 16-bit parallel input

High definition output formats

YPrPb HDTV (EIA 770.3)

RGB, RGBHV

CGMS-A (720p/1080i)

Enhanced definition output formats

Macrovision Rev 1.2 (525p/625p)

CGMS-A (525p/625p)

YPrPb progressive scan (EIA-770.1, EIA-770.2)

RGB, RGBHV

Standard definition output formats

Composite NTSC M/N

Composite PAL M/N/B/D/G/H/I, PAL-60

SMPTE 170M NTSC-compatible composite video

ITU-R BT.470 PAL-compatible composite video

S-video (Y/C)

EuroScart RGB

Component YPrPb (Betacam, MII, SMPTE/EBU N10)

Macrovision Rev 7.1.L1

CGMS/WSS

Closed captioning

GENERAL FEATURES

Simultaneous SD/HD, PS/SD inputs and outputs

Oversampling up to 216 MHz

Programmable DAC gain control

Sync outputs in all modes

On-board voltage reference

Six 11-bit precision video DACs

2-wire serial I²C® interface, open-drain configuration

Dual I/O supply 2.5 V/3.3 V operation

Analog and digital supply 2.5 V

On-board PLL

64-lead LQFP package

Lead (Pb)-free product

APPLICATIONS

EVD players (enhanced versatile disk)

SD/PS DVD recorders/players

SD/progressive scan/HDTV display devices

SD/HDTV set top boxes

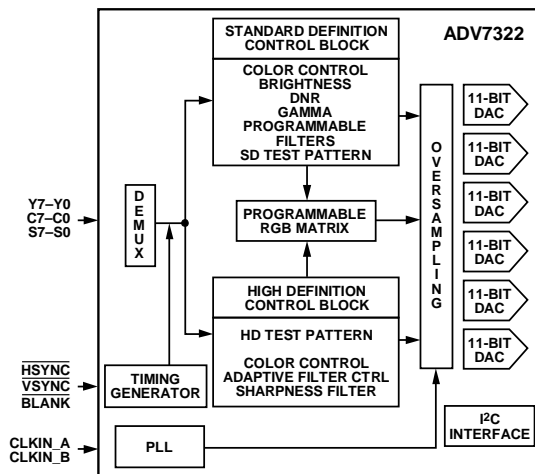

Figure 1. Simplified Functional Block Diagram

GENERAL DESCRIPTION

The ADV[®]7322 is a high speed, digital-to-analog encoder on a single monolithic chip. It includes six high speed video DACs with TTL compatible inputs. It has separate 8-, 16-, 24-bit input ports that accept data in high definition and/or standard definition video format. For all standards, external horizontal, vertical, and blanking signals or EAV/SAV timing codes control the insertion of appropriate synchronization signals into the digital data stream and therefore the output signal.

Rev. PrA

Information furnished by Analog Devices is believed to be accurate and reliable. However, no responsibility is assumed by Analog Devices for its use, nor for any infringements of patents or other rights of third parties that may result from its use. Specifications subject to change without notice. No license is granted by implication or otherwise under any patent or patent rights of Analog Devices. Trademarks and registered trademarks are the property of their respective owners.

One Technology Way, P.O. Box 9106, Norwood, MA 02062-9106, U.S.A.
Tel: 781.329.4700 www.analog.com
Fax: 781.326.8703 © 2004 Analog Devices, Inc. All rights reserved.

ADV7322

Preliminary Technical Data

DETAILED FEATURES

High definition programmable features (720p/1080i/1035i)

2× oversampling (148.5 MHz)

Internal test pattern generator

Color hatch, black bar, flat field/frame

Fully programmable YCrCb to RGB matrix

Gamma correction

Programmable adaptive filter control

Programmable sharpness filter control

CGMS-A (720p/1080i)

Enhanced definition programmable features (525p/625p)

8× oversampling (216 MHz output)

Internal test pattern generator

Color hatch, black bar, flat frame

Individual Y and PrPb output delay

Gamma correction

Programmable adaptive filter control

Fully programmable YCrCb to RGB matrix

Undershoot limiter

Macrovision Rev 1.2 (525p/625p)

CGMS-A (525p/625p)

Standard definition programmable features

16× oversampling (216 MHz)

Internal test pattern generator

Color bars, black bar

Controlled edge rates for start and end of active video

Individual Y and PrPb output delay

Undershoot limiter

Gamma correction

Digital noise reduction (DNR)

Multiple chroma and luma filters

Luma-SSAF™ filter with programmable gain/attenuation

PrPb SSAF™

Separate pedestal control on component and composite/S-video output

VCR FF/RW sync mode

Macrovision Rev 7.1.L1

CGMS/WSS

Closed captioning

Table 1. Standards Directly Supported¹

Resolution	Interlace/ Prog.	Frame Rate (Hz)	CLK Input (MHz)	Standard
720 × 480	I	29.97	27	ITU-R BT.656
720 × 576	I	25	27	ITU-R BT.656
720 × 480	I	29.97	24.54	NTSC Square Pixel
720 × 576	I	25	29.5	PAL Square Pixel
720 × 483	P	59.94	27	SMPTE 293M
720 × 483	P	59.94	27	BTA T-1004
720 × 483	P	59.94	27	ITU-R BT.1358
720 × 576	P	50	27	ITU-R BT.1358
720 × 483	P	59.94	27	ITU-R BT.1362
720 × 576	P	50	27	ITU-R BT.1362
1920 × 1035	I	30	74.25	SMPTE 240M
1280 × 720	P	60, 50, 30,	74.25,	SMPTE 296M
		25, 24,	74.1758	
		23.97, 59.94, 29.97	74.1758	
1920 × 1080	I	30, 25	74.25	SMPTE 274M
1920 × 1080	P	29.97	74.1758	SMPTE 274M
		30, 25, 24	74.25	
1920 × 1080	P	23.98,	74.1758	SMPTE 274M
		29.97,		

¹ Other standards are supported in async timing mode.

Preliminary Technical Data

ADV7322

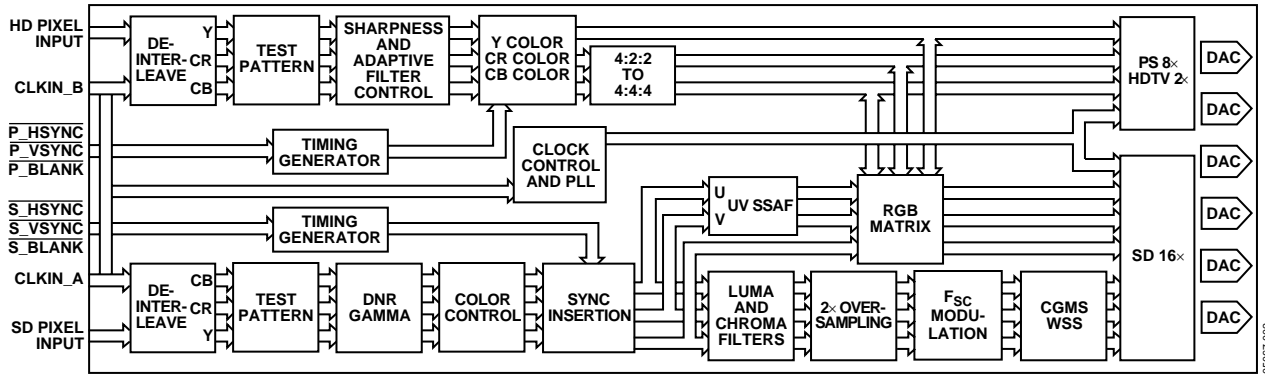

Figure 2. Detailed Functional Block Diagram

TERMINOLOGY

SD: standard definition video, conforming to ITU-R BT.601/ITU-R BT.656.

HD: high definition video, i.e., 720p/1080i/1035i.

EDTV: enhanced definition television (525p/625p)

PS: progressive scan video, conforming to SMPTE 293M, ITU-R BT.1358, BTAT-1004EDTV2, or ITU-R BT.13621362.

HDTV: high definition television video, conforming to SMPTE 274M, or SMPTE 296M and SMPTE240M.

YCrCb SD, PS, or HD component: digital video.

YPrPb SD, PS, or HD component: analog video.

ADV7322

Preliminary Technical Data

PIN CONFIGURATION AND FUNCTION DESCRIPTIONS

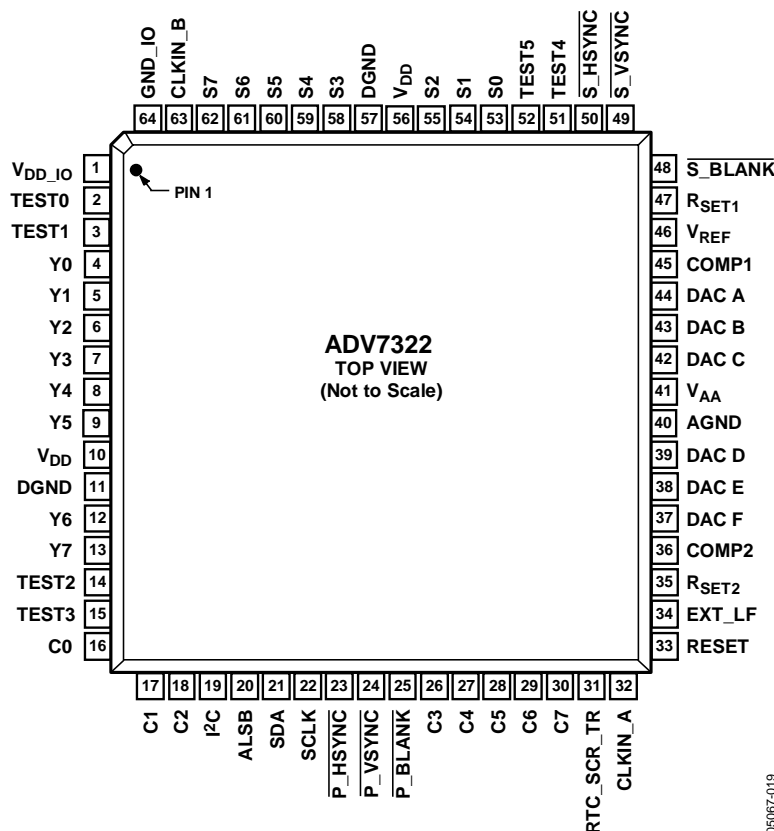

Preliminary Technical Data

ADV7322

Table 6. Pin Function Descriptions

Mnemonic	Input/Output	Function
DGND	G	Digital Ground.
AGND	G	Analog Ground.
CLKIN_A	I	Pixel Clock Input for HD (74.25 MHz Only, PS Only (27 MHz), SD Only (27 MHz).
CLKIN_B	I	Pixel Clock Input. Requires a 27 MHz reference clock for progressive scan mode or a 74.25 MHz (74.1758 MHz) reference clock in HDTV mode. This clock is only used in dual modes.
COMP1, COMP2	O	Compensation Pin for DACs. Connect 0.1 μ F capacitor from COMP pin to V_{AA} .
DAC A	O	CVBS/Green/Y/Y Analog Output.
DAC B	O	Chroma/Blue/U/Pb Analog Output.
DAC C	O	Luma/Red/V/Pr Analog Output.
DAC D	O	In SD Only Mode: CVBS/Green/Y Analog Output; in HD Only Mode and Simultaneous HD/SD Mode: Y/Green [HD] Analog Output.
DAC E	O	In SD Only Mode: Luma/Blue/U Analog Output; in HD Only Mode and Simultaneous HD/SD Mode: Pr/Red Analog Output.
DAC F	O	In SD Only Mode: Chroma/Red/V Analog Output; in HD Only Mode and Simultaneous HD/SD Mode: Pb/Blue [HD] Analog Output.
<u>P_HSYNC</u>	I	Video Horizontal Sync Control Signal for HD in Simultaneous SD/HD Mode and HD Only Mode.
<u>P_VSYNC</u>	I	Video Vertical Sync Control Signal for HD in Simultaneous SD/HD Mode and HD Only Mode.
<u>P_BLANK</u>	I	Video Blanking Control Signal for HD in Simultaneous SD/HD Mode and HD Only Mode.
<u>S_BLANK</u>	I/O	Video Blanking Control Signal for SD Only.
<u>S_HSYNC</u>	I/O	Video Horizontal Sync Control Signal for SD Only.
<u>S_VSYNC</u>	I/O	Video Vertical Sync Control Signal for SD Only.
Y7 to Y0	I	SD or Progressive Scan/HDTV Input Port for Y Data. Input port for interleaved progressive scan data. The LSB is set up on Pin Y0.
C7 to C0	I	Progressive Scan/HDTV Input Port 4:4:4 Input Mode. This port is used for the Cb [Blue/U] data. The LSB is set up on Pin C0.
S7 to S0	I	SD or Progressive Scan/HDTV Input Port for Cr [Red/V] data in 4:4:4 input mode. LSB is set up on Pin S0.
<u>RESET</u>	I	This input resets the on-chip timing generator and sets the ADV7322 into default register setting. <u>RESET</u> is an active low signal.
RSET1, RSET2	I	A 3040 Ω resistor must be connected from this pin to AGND and is used to control the amplitudes of the DAC outputs.
SCLK	I	I ² C Port Serial Interface Clock Input.
SDA	I/O	I ² C Port Serial Data Input/Output.
ALSB	I	TTL Address Input. This signal sets up the LSB of the I ² C address. When this pin is tied low, the I ² C filter is activated, which reduces noise on the I ² C interface.
V _{DD_IO}	P	Power Supply for Digital Inputs and Outputs.
V _{DD}	P	Digital Power Supply.
V _{AA}	P	Analog Power Supply.
V _{REF}	I/O	Optional External Voltage Reference Input for DACs or Voltage Reference Output (1.235 V).
EXT_LF	I	External Loop Filter for the Internal PLL.
RTC_SCR_TR	I	Multifunctional Input. Real time control (RTC) input, timing reset input, subcarrier reset input.
I ² C	I	This input pin must be tied high (V _{DD_IO}) for the ADV7322 to interface over the I ² C port.
GND_IO	I	Digital Input/Output Ground.
TEST0 to TEST5	I	Not used. Tie to DGND



74VHC08

QUAD 2-INPUT AND GATE

- HIGH SPEED: $t_{PD} = 4.3 \text{ ns}$ (TYP.) at $V_{CC} = 5V$
- LOW POWER DISSIPATION:
 $I_{CC} = 2 \mu\text{A}$ (MAX.) at $T_A = 25^\circ\text{C}$
- HIGH NOISE IMMUNITY:
 $V_{NIH} = V_{NIL} = 28\% V_{CC}$ (MIN.)
- POWER DOWN PROTECTION ON INPUTS
- SYMMETRICAL OUTPUT IMPEDANCE:
 $|I_{OH}| = I_{OL} = 8\text{mA}$ (MIN)
- BALANCED PROPAGATION DELAYS:
 $t_{PLH} \cong t_{PHL}$
- OPERATING VOLTAGE RANGE:
 $V_{CC}(\text{OPR}) = 2V$ to $5.5V$
- PIN AND FUNCTION COMPATIBLE WITH 74 SERIES 08
- IMPROVED LATCH-UP IMMUNITY
- LOW NOISE: $V_{OLP} = 0.8V$ (MAX.)

DESCRIPTION

The 74VHC08 is an advanced high-speed CMOS QUAD 2-INPUT AND GATE fabricated with sub-micron silicon gate and double-layer metal wiring C²MOS technology.

The internal circuit is composed of 2 stages including buffer output, which provides high noise immunity and stable output.

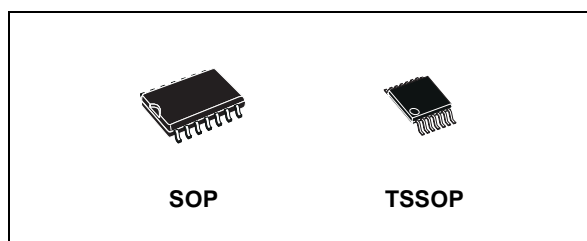

ORDER CODES

PACKAGE	TUBE	T & R
SOP	74VHC08M	74VHC08MTR
TSSOP		74VHC08TTR

Power down protection is provided on all inputs and 0 to 7V can be accepted on inputs with no regard to the supply voltage. This device can be used to interface 5V to 3V.

All inputs and outputs are equipped with protection circuits against static discharge, giving them 2KV ESD immunity and transient excess voltage.

PIN CONNECTION AND IEC LOGIC SYMBOLS

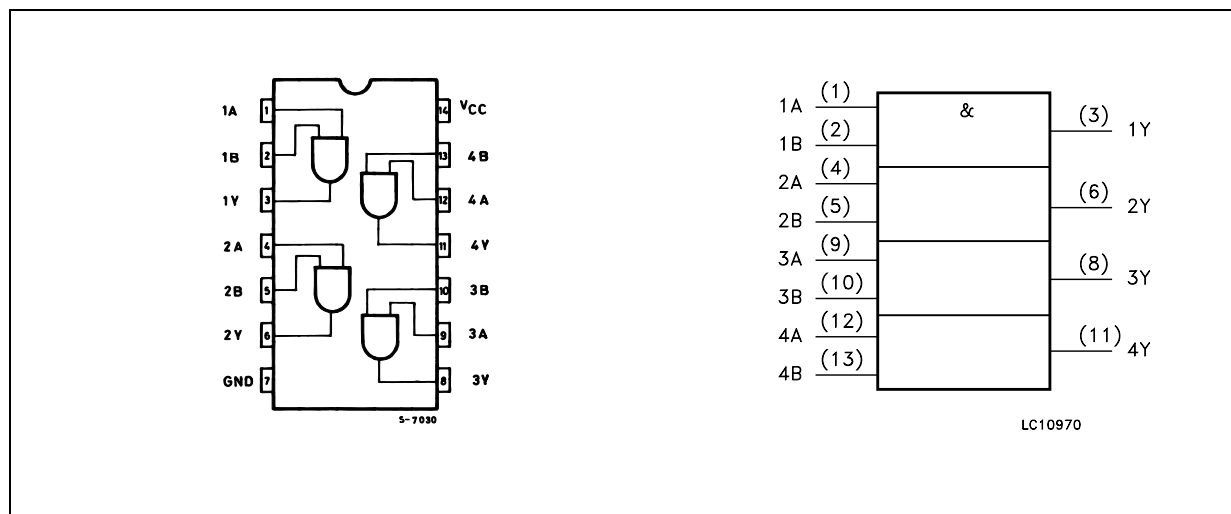

74VHC08

INPUT EQUIVALENT CIRCUIT

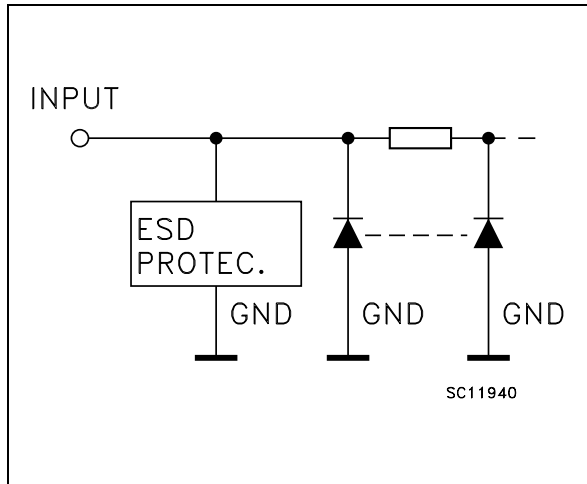

PIN DESCRIPTION

PIN No	SYMBOL	NAME AND FUNCTION
1, 4, 9, 12	1A to 4A	Data Inputs
2, 5, 10, 13	1B to 4B	Data Inputs
3, 6, 8, 11	1Y to 4Y	Data Outputs
7	GND	Ground (0V)
14	V _{CC}	Positive Supply Voltage

TRUTH TABLE

A	B	Y
L	L	L
L	H	L
H	L	L
H	H	H

ABSOLUTE MAXIMUM RATINGS

Symbol	Parameter	Value	Unit
V _{CC}	Supply Voltage	-0.5 to +7.0	V
V _I	DC Input Voltage	-0.5 to +7.0	V
V _O	DC Output Voltage	-0.5 to V _{CC} + 0.5	V
I _{IK}	DC Input Diode Current	- 20	mA
I _{OK}	DC Output Diode Current	± 20	mA
I _O	DC Output Current	± 25	mA
I _{CC} or I _{GND}	DC V _{CC} or Ground Current	± 50	mA
T _{stg}	Storage Temperature	-65 to +150	°C
T _L	Lead Temperature (10 sec)	300	°C

Absolute Maximum Ratings are those values beyond which damage to the device may occur. Functional operation under these conditions is not implied.

RECOMMENDED OPERATING CONDITIONS

Symbol	Parameter	Value	Unit
V _{CC}	Supply Voltage	2 to 5.5	V
V _I	Input Voltage	0 to 5.5	V
V _O	Output Voltage	0 to V _{CC}	V
T _{op}	Operating Temperature	-55 to 125	°C
dt/dv	Input Rise and Fall Time (note 1) (V _{CC} = 3.3 ± 0.3V) (V _{CC} = 5.0 ± 0.5V)	0 to 100 0 to 20	ns/V

1) V_{IN} from 30% to 70% of V_{CC}

AKM

AK4384

106dB 192kHz 24-Bit 2ch $\Delta\Sigma$ DAC

GENERAL DESCRIPTION

The AK4384 offers the perfect mix for cost and performance based audio systems. Using AKM's multi bit architecture for its modulator the AK4384 delivers a wide dynamic range while preserving linearity for improved THD+N performance. The AK4384 integrates a combination of SCF and CTF filters increasing performance for systems with excessive clock jitter. The 24 Bit word length and 192kHz sampling rate make this part ideal for a wide range of applications including DVD-Audio. The AK4384 is offered in a space saving 16pin TSSOP package.

FEATURES

- Sampling Rate Ranging from 8kHz to 192kHz
- 128 times Oversampling (Normal Speed Mode)
- 64 times Oversampling (Double Speed Mode)
- 32 times Oversampling (Quad Speed Mode)
- 24-Bit 8 times FIR Digital Filter
- SCF with High Tolerance to Clock Jitter
- 2nd order Analog LPF
- Single Ended Output Buffer
- Digital de-emphasis for 32k, 44.1k and 48kHz sampling
- Soft mute
- Digital Attenuator (Linear 256 steps)
- I/F format: 24-Bit MSB justified, 24/20/16-Bit LSB justified or I^2S
- Master clock: 256fs, 384fs, 512fs, 768fs or 1152fs (Normal Speed Mode)
128fs, 192fs, 256fs or 384fs (Double Speed Mode)
128fs, 192fs (Quad Speed Mode)
- THD+N: -94dB
- Dynamic Range: 106dB
- Power supply: 4.5 to 5.5V
- Very Small Package: 16pin TSSOP (6.4mm x 5.0mm)

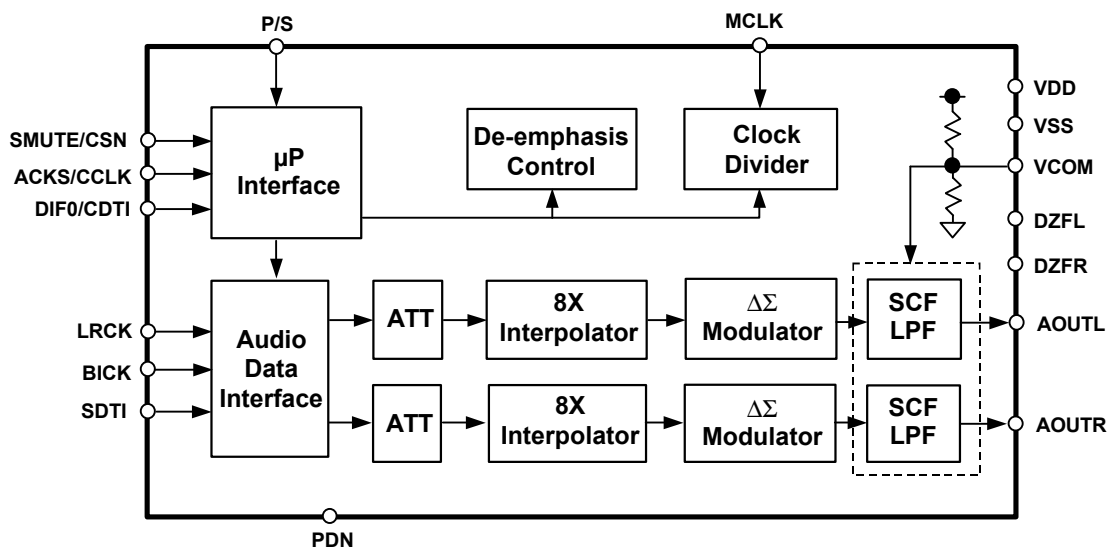

ASAHI KASEI

[AK4384]

■ Ordering Guide

AK4384VT
AKD4384

-40 ~ +85°C

16pin TSSOP (0.65mm pitch)

Evaluation Board for AK4384

■ Pin Layout

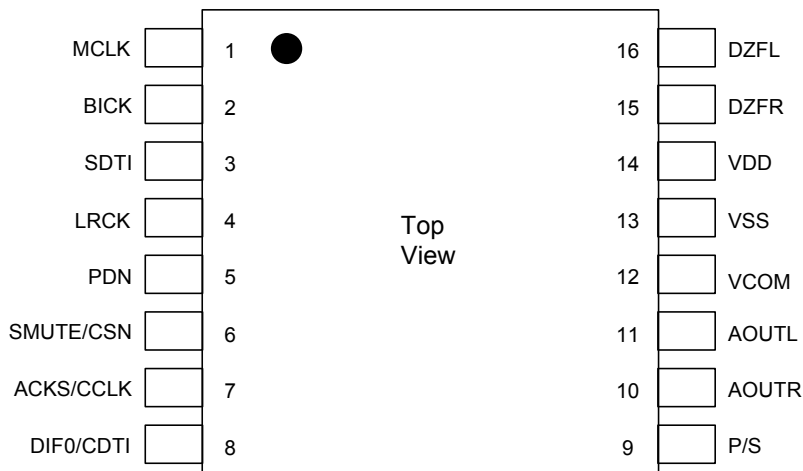

PIN/FUNCTION

No.	Pin Name	I/O	Function
1	MCLK	I	Master Clock Input Pin An external TTL clock should be input on this pin.
2	BICK	I	Audio Serial Data Clock Pin
3	SDTI	I	Audio Serial Data Input Pin
4	LRCK	I	L/R Clock Pin
5	PDN	I	Power-Down Mode Pin When at "L", the AK4384 is in the power-down mode and is held in reset. The AK4384 should always be reset upon power-up.
6	SMUTE	I	Soft Mute Pin in parallel mode "H": Enable, "L": Disable
	CSN	I	Chip Select Pin in serial mode
7	ACKS	I	Auto Setting Mode Pin in parallel mode "L": Manual Setting Mode, "H": Auto Setting Mode
	CCLK	I	Control Data Clock Pin in serial mode
8	DIF0	I	Audio Data Interface Format Pin in parallel mode
	CDTI	I	Control Data Input Pin in serial mode
9	P/S	I	Parallel/Serial Select Pin (Internal pull-up pin) "L": Serial control mode, "H": Parallel control mode
10	AOUTR	O	Rch Analog Output Pin
11	AOUTL	O	Lch Analog Output Pin
12	VCOM	O	Common Voltage Pin, VDD/2 Normally connected to VSS with a 0.1μF ceramic capacitor in parallel with a 10μF electrolytic cap.
13	VSS	-	Ground Pin
14	VDD	-	Power Supply Pin
15	DZFR	O	Rch Data Zero Input Detect Pin
16	DZFL	O	Lch Data Zero Input Detect Pin

Note: All input pins except pull-up pin should not be left floating.



74LCX32

LOW VOLTAGE CMOS QUAD 2-INPUT OR GATE WITH 5V TOLERANT INPUTS

- 5V TOLERANT INPUTS
- HIGH SPEED:
 $t_{PD} = 5.2\text{ns (MAX.) at } V_{CC} = 3\text{V}$
- POWER DOWN PROTECTION ON INPUTS AND OUTPUTS
- SYMMETRICAL OUTPUT IMPEDANCE:
 $|I_{OH}| = I_{OL} = 24\text{mA (MIN) at } V_{CC} = 3\text{V}$
- PCI BUS LEVELS GUARANTEED AT 24 mA
- BALANCED PROPAGATION DELAYS:
 $t_{PLH} \cong t_{PHL}$
- OPERATING VOLTAGE RANGE:
 $V_{CC(OPR)} = 2.0\text{V to } 3.6\text{V (1.5V Data Retention)}$
- PIN AND FUNCTION COMPATIBLE WITH 74 SERIES 32
- LATCH-UP PERFORMANCE EXCEEDS 500mA (JESD 17)
- ESD PERFORMANCE:
HBM > 2000V (MIL STD 883 method 3015);
MM > 200V

DESCRIPTION

The 74LCX32 is a low voltage CMOS QUAD 2-INPUT OR GATE fabricated with sub-micron silicon gate and double-layer metal wiring C²MOS

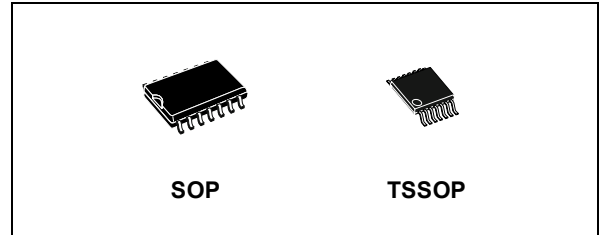

Table 1: Order Codes

PACKAGE	T & R
SOP	74LCX32MTR
TSSOP	74LCX32TTR

technology. It is ideal for low power and high speed 3.3V applications; it can be interfaced to 5V signal environment for inputs.

It has same speed performance at 3.3V than 5V AC/ACT family, combined with a lower power consumption.

All inputs and outputs are equipped with protection circuits against static discharge, giving them 2KV ESD immunity and transient excess voltage.

Figure 1: Pin Connection And IEC Logic Symbols

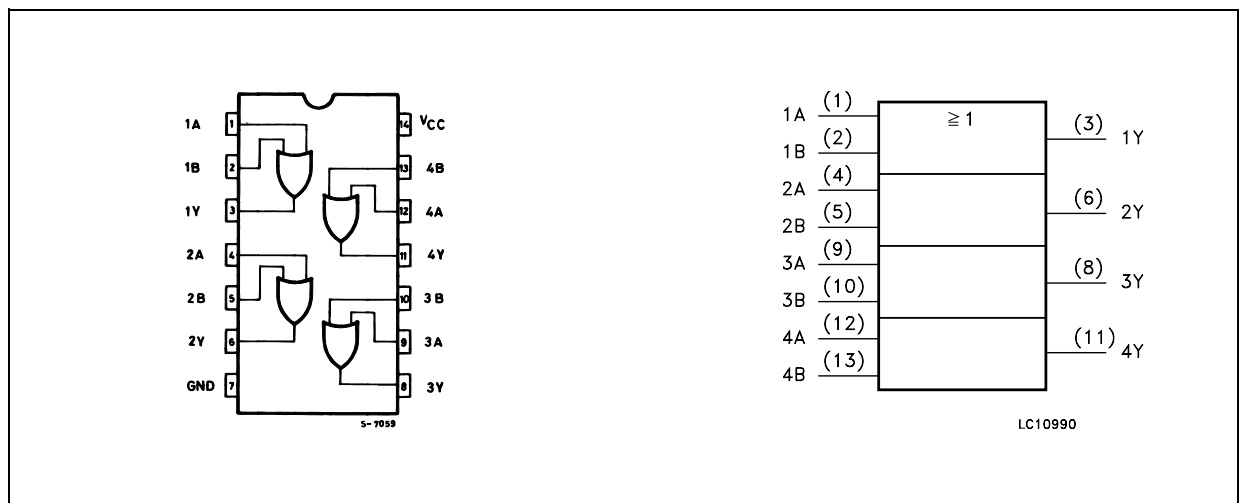

74LCX32

Figure 2: Input And Output Equivalent Circuit

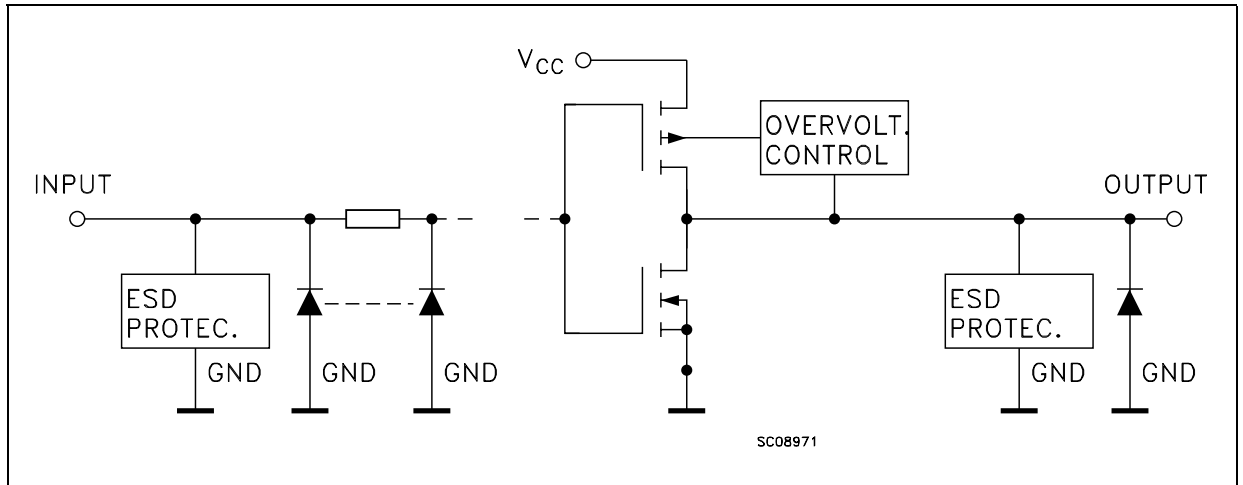

Table 2: Pin Description

PIN N°	SYMBOL	NAME AND FUNCTION
1, 4, 9, 12	1A to 4A	Data Inputs
2, 5, 10, 13	1B to 4B	Data Inputs
3, 6, 8, 11	1Y to 4Y	Data Outputs
7	GND	Ground (0V)
14	V_{CC}	Positive Supply Voltage

Table 3: Truth Table

A	B	Y
L	L	L
L	H	H
H	L	H
H	H	H

Table 4: Absolute Maximum Ratings

Symbol	Parameter	Value	Unit
V_{CC}	Supply Voltage	-0.5 to +7.0	V
V_I	DC Input Voltage	-0.5 to +7.0	V
V_O	DC Output Voltage ($V_{CC} = 0V$)	-0.5 to +7.0	V
V_O	DC Output Voltage (High or Low State) (note 1)	-0.5 to $V_{CC} + 0.5$	V
I_{IK}	DC Input Diode Current	- 50	mA
I_{OK}	DC Output Diode Current (note 2)	- 50	mA
I_O	DC Output Current	± 50	mA
I_{CC}	DC Supply Current per Supply Pin	± 100	mA
I_{GND}	DC Ground Current per Supply Pin	± 100	mA
T_{stg}	Storage Temperature	-65 to +150	$^{\circ}C$
T_L	Lead Temperature (10 sec)	300	$^{\circ}C$

Absolute Maximum Ratings are those values beyond which damage to the device may occur. Functional operation under these conditions is not implied

- 1) I_O absolute maximum rating must be observed
- 2) $V_O < GND$



74ACT04

HEX INVERTER

- HIGH SPEED: $t_{pD} = 5.0ns$ (TYP.) at $V_{CC} = 5V$
- LOW POWER DISSIPATION:
 $I_{CC} = 2\mu A$ (MAX.) at $T_A=25^\circ C$
- COMPATIBLE WITH TTL OUTPUTS
 $V_{IH} = 2V$ (MIN.), $V_{IL} = 0.8V$ (MAX.)
- 50Ω TRANSMISSION LINE DRIVING CAPABILITY
- SYMMETRICAL OUTPUT IMPEDANCE:
 $|I_{OH}| = I_{OL} = 24mA$ (MIN)
- BALANCED PROPAGATION DELAYS:
 $t_{PLH} \approx t_{PHL}$
- OPERATING VOLTAGE RANGE:
 V_{CC} (OPR) = 4.5V to 5.5V
- PIN AND FUNCTION COMPATIBLE WITH 74 SERIES 04
- IMPROVED LATCH-UP IMMUNITY

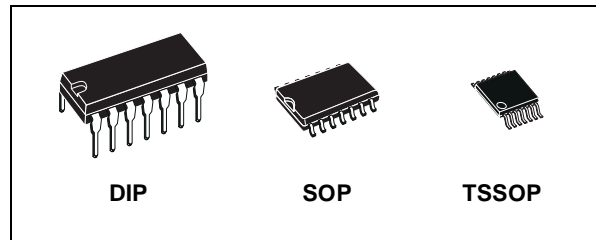

ORDER CODES

PACKAGE	TUBE	T & R
DIP	74ACT04B	
SOP	74ACT04M	74ACT04MTR
TSSOP		74ACT04TTR

DESCRIPTION

The 74ACT04 is an advanced high-speed CMOS HEX INVERTER fabricated with sub-micron silicon gate and double-layer metal wiring C²MOS technology.

The internal circuit is composed of 3 stages including buffer output, which enables high noise immunity and stable output.

The device is designed to interface directly High Speed CMOS systems with TTL, NMOS and CMOS output voltage levels.

All inputs and outputs are equipped with protection circuits against static discharge, giving them 2KV ESD immunity and transient excess voltage.

PIN CONNECTION AND IEC LOGIC SYMBOLS

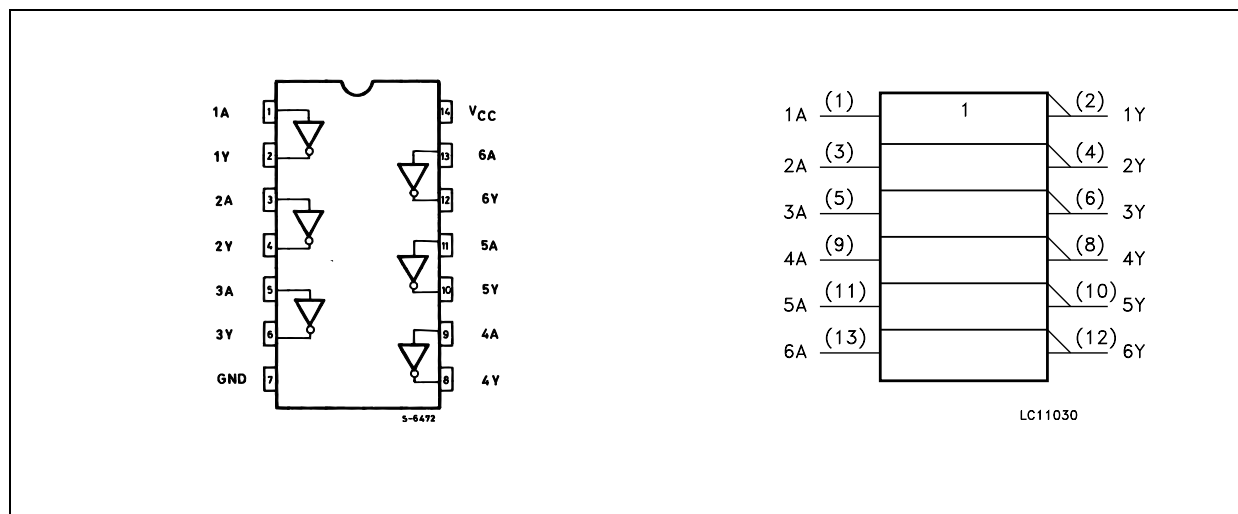

74ACT04

INPUT AND OUTPUT EQUIVALENT CIRCUIT

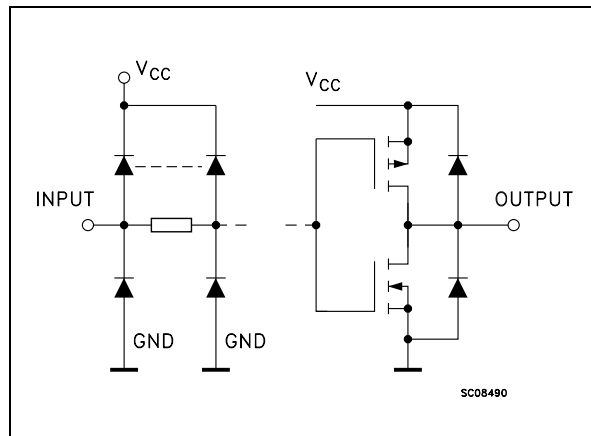

PIN DESCRIPTION

PIN No	SYMBOL	NAME AND FUNCTION
1, 3, 5, 9, 11, 13	1A to 6A	Data Inputs
2, 4, 6, 8, 10, 12	1Y to 6Y	Data Outputs
7	GND	Ground (0V)
14	V _{CC}	Positive Supply Voltage

TRUTH TABLE

A	Y
L	H
H	L

ABSOLUTE MAXIMUM RATINGS

Symbol	Parameter	Value	Unit
V _{CC}	Supply Voltage	-0.5 to +7	V
V _I	DC Input Voltage	-0.5 to V _{CC} + 0.5	V
V _O	DC Output Voltage	-0.5 to V _{CC} + 0.5	V
I _{IK}	DC Input Diode Current	± 20	mA
I _{OK}	DC Output Diode Current	± 20	mA
I _O	DC Output Current	± 50	mA
I _{CC} or I _{GND}	DC V _{CC} or Ground Current	± 200	mA
T _{stg}	Storage Temperature	-65 to +150	°C
T _L	Lead Temperature (10 sec)	300	°C

Absolute Maximum Ratings are those values beyond which damage to the device may occur. Functional operation under these conditions is not implied.

RECOMMENDED OPERATING CONDITIONS

Symbol	Parameter	Value	Unit
V _{CC}	Supply Voltage	4.5 to 5.5	V
V _I	Input Voltage	0 to V _{CC}	V
V _O	Output Voltage	0 to V _{CC}	V
T _{op}	Operating Temperature	-55 to 125	°C
dt/dv	Input Rise and Fall Time V _{CC} = 4.5 to 5.5V (note 1)	8	ns/V

1) V_{IN} from 0.8V to 2.0V



CS42528

114 dB, 192 kHz 8-Ch Codec with S/PDIF Receiver

Features

- Eight 24-bit D/A, two 24-bit A/D Converters
- 114 dB DAC / 114 dB ADC Dynamic Range
- -100 dB THD+N
- System Sampling Rates up to 192 kHz
- S/PDIF Receiver Compatible with EIAJ CP1201 and IEC-60958
- Recovered S/PDIF Clock or System Clock Selection
- 8:2 S/PDIF Input MUX
- ADC High-pass Filter for DC Offset Calibration
- Expandable ADC Channels and One-line Mode Support
- Digital Output Volume Control with Soft Ramp
- Digital +/-15dB Input Gain Adjust for ADC
- Differential Analog Architecture
- Supports logic levels between 5 V and 1.8 V.

General Description

The CS42528 codec provides two analog-to-digital and eight digital-to-analog delta-sigma converters, as well as an integrated S/PDIF receiver, in a 64-pin LQFP package.

The CS42528 integrated S/PDIF receiver supports up to eight inputs, clock recovery circuitry and format auto-detection. The internal stereo ADC is capable of independent channel gain control for single-ended or differential analog inputs. All eight channels of DAC provide digital volume control and differential analog outputs. The general purpose outputs may be driven high or low, or mapped to a variety of DAC mute controls or ADC overflow indicators.

The CS42528 is ideal for audio systems requiring wide dynamic range, negligible distortion and low noise, such as A/V receivers, DVD receivers, digital speaker and automotive audio systems.

ORDERING INFORMATION

CS42528-CQZ	-10° to 70° C	64-pin LQFP	Lead Free
CS42528-DQZ	-40° to 85° C	64-pin LQFP	Lead Free
CDB42528		Evaluation Board	

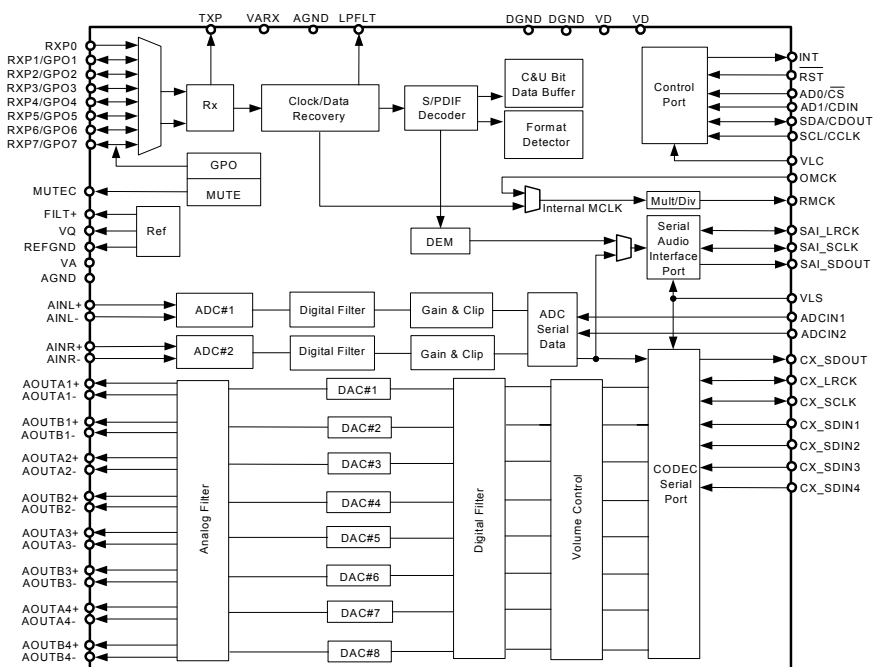

Preliminary Product Information

Cirrus Logic, Inc.
<http://www.cirrus.com>



CS42528

2. PIN DESCRIPTIONS

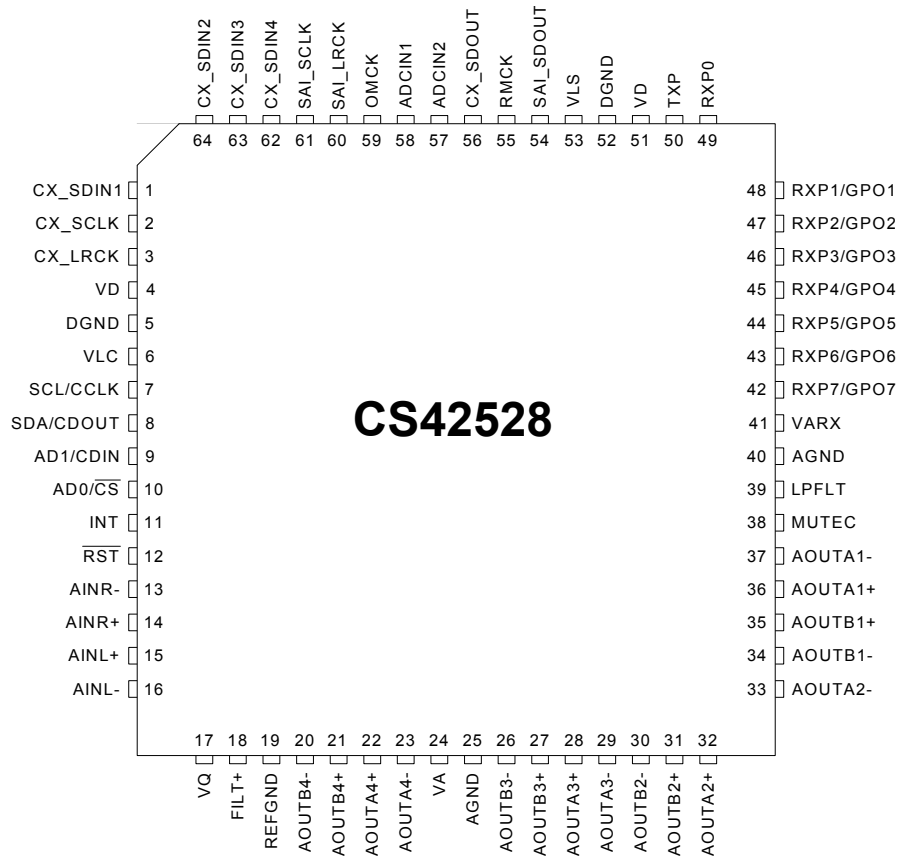

Pin Name	#	Pin Description
CX_SDIN1	1	Codec Serial Audio Data Input (Input) - Input for two's complement serial audio data.
CX_SDIN2	64	
CX_SDIN3	63	
CX_SDIN4	62	
CX_SCLK	2	CODEC Serial Clock (Input/Output) - Serial clock for the CODEC serial audio interface.
CX_LRCK	3	CODEC Left Right Clock (Input/Output) - Determines which channel, Left or Right, is currently active on the CODEC serial audio data line.
VD	4 51	Digital Power (Input) - Positive power supply for the digital section.
DGND	5 52	Digital Ground (Input) - Ground reference. Should be connected to digital ground.
VLC	6	Control Port Power (Input) - Determines the required signal level for the control port.
SCL/CCLK	7	Serial Control Port Clock (Input) - Serial clock for the serial control port. Requires an external pull-up resistor to the logic interface voltage in I ² C mode as shown in the Typical Connection Diagram.
SDA/CDOUT	8	Serial Control Data (Input/Output) - SDA is a data I/O line in I ² C mode and requires an external pull-up resistor to the logic interface voltage, as shown in the Typical Connection Diagram. CDOUT is the output data line for the control port interface in SPI mode.
AD1/CDIN	9	Address Bit 1 (I²C)/Serial Control Data (SPI) (Input) - AD1 is a chip address pin in I ² C mode; CDIN is the input data line for the control port interface in SPI mode.



CS42528

AD0/CS	10	Address Bit 0 (I²C)/Control Port Chip Select (SPI) (Input) - AD0 is a chip address pin in I ² C mode; CS is the chip select signal in SPI mode.
INT	11	Interrupt (Output) - The CS42528 will generate an interrupt condition as per the Interrupt Mask register. See "Interrupts" on page 40 for more details.
RST	12	Reset (Input) - The device enters a low power mode and all internal registers are reset to their default settings when low.
AINR- AINR+	13 14	Differential Right Channel Analog Input (Input) - Signals are presented differentially to the delta-sigma modulators via the AINR+/- pins.
AINL+ AINL-	15 16	Differential Left Channel Analog Input (Input) - Signals are presented differentially to the delta-sigma modulators via the AINL+/- pins.
VQ	17	Quiescent Voltage (Output) - Filter connection for internal quiescent reference voltage.
FILT+	18	Positive Voltage Reference (Output) - Positive reference voltage for the internal sampling circuits.
REFGND	19	Reference Ground (Input) - Ground reference for the internal sampling circuits.
AOUTA1 +,- AOUTB1 +,- AOUTA2 +,- AOUTB2 +,- AOUTA3 +,- AOUTB3 +,- AOUTA4 +,- AOUTB4 +,-	36,37 35,34 32,33 31,30 28,29 27,26 22,23 21,20	Differential Analog Output (Output) - The full-scale differential analog output level is specified in the Analog Characteristics specification table.
VA VARX	24 41	Analog Power (Input) - Positive power supply for the analog section.
AGND	25 40	Analog Ground (Input) - Ground reference. Should be connected to analog ground.
MUTECL	38	Mute Control (Output) - The Mute Control pin outputs high impedance following an initial power-on condition or whenever the PDN bit is set to a '1', forcing the codec into power-down mode. The signal will remain in a high impedance state as long as the part is in power-down mode. The Mute Control pin goes to the selected "active" state during reset, muting, or if the master clock to left/right clock frequency ratio is incorrect. This pin is intended to be used as a control for external mute circuits to prevent the clicks and pops that can occur in any single supply system. The use of external mute circuits are not mandatory but may be desired for designs requiring the absolute minimum in extraneous clicks and pops.
LPFLT	39	PLL Loop Filter (Output) - An RC network should be connected between this pin and ground.
RXP7/GPO7 RXP6/GPO6 RXP5/GPO5 RXP4/GPO4 RXP3/GPO3 RXP2/GPO2 RXP1/GPO1	42 43 44 45 46 47 48	S/PDIF Receiver Input/ General Purpose Output (Input/Output) - Receiver inputs for S/PDIF encoded data. The CS42528 has an internal 8:2 multiplexer to select the active receiver port, according to the Receiver Mode Control 2 register. These pins can also be configured as general purpose output pins, ADC Overflow indicators or Mute Control outputs according to the RXP/General Purpose Pin Control registers.
RXP0	49	S/PDIF Receiver Input (Input) - Dedicated receiver input for S/PDIF encoded data.
TXP	50	S/PDIF Transmitter Output (Output) - S/PDIF encoded data output, mapped directly from one of the receiver inputs as indicated by the Receiver Mode Control 2 register.
VLS	53	Serial Port Interface Power (Input) - Determines the required signal level for the serial port interfaces.
SAI_SDOUT	54	Serial Audio Interface Serial Data Output (Output) - Output for two's complement serial audio PCM data from the S/PDIF incoming stream. This pin can also be configured to transmit the output of the internal and external ADCs.
RMCK	55	Recovered Master Clock (Output) - Recovered master clock output from the External Clock Reference (OMCK, pin 59) or the PLL which is locked to the incoming S/PDIF stream or CX_LRCK.



CS42528

CX_SDOUT	56	CODEC Serial Data Output (<i>Output</i>) - Output for two's complement serial audio data from the internal and external ADCs.
ADCIN1	58	External ADC Serial Input (<i>Input</i>) - The CS42528 provides for up to two external stereo analog to digital converter inputs to provide a maximum of six channels on one serial data output line when the CS42528 is placed in One Line mode.
ADCIN2	57	
OMCK	59	External Reference Clock (<i>Input</i>) - External clock reference that must be within the ranges specified in the register "OMCK Frequency (OMCK Freqx)" on page 54.
SAI_LRCK	60	Serial Audio Interface Left/Right Clock (<i>Input/Output</i>) - Determines which channel, Left or Right, is currently active on the serial audio data line.
SAI_SCLK	61	Serial Audio Interface Serial Clock (<i>Input/Output</i>) - Serial clock for the Serial Audio Interface.

OUTER DIMENSIONS

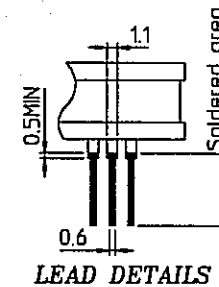
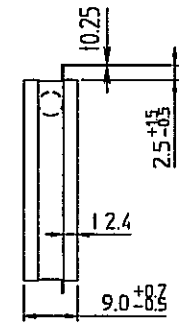
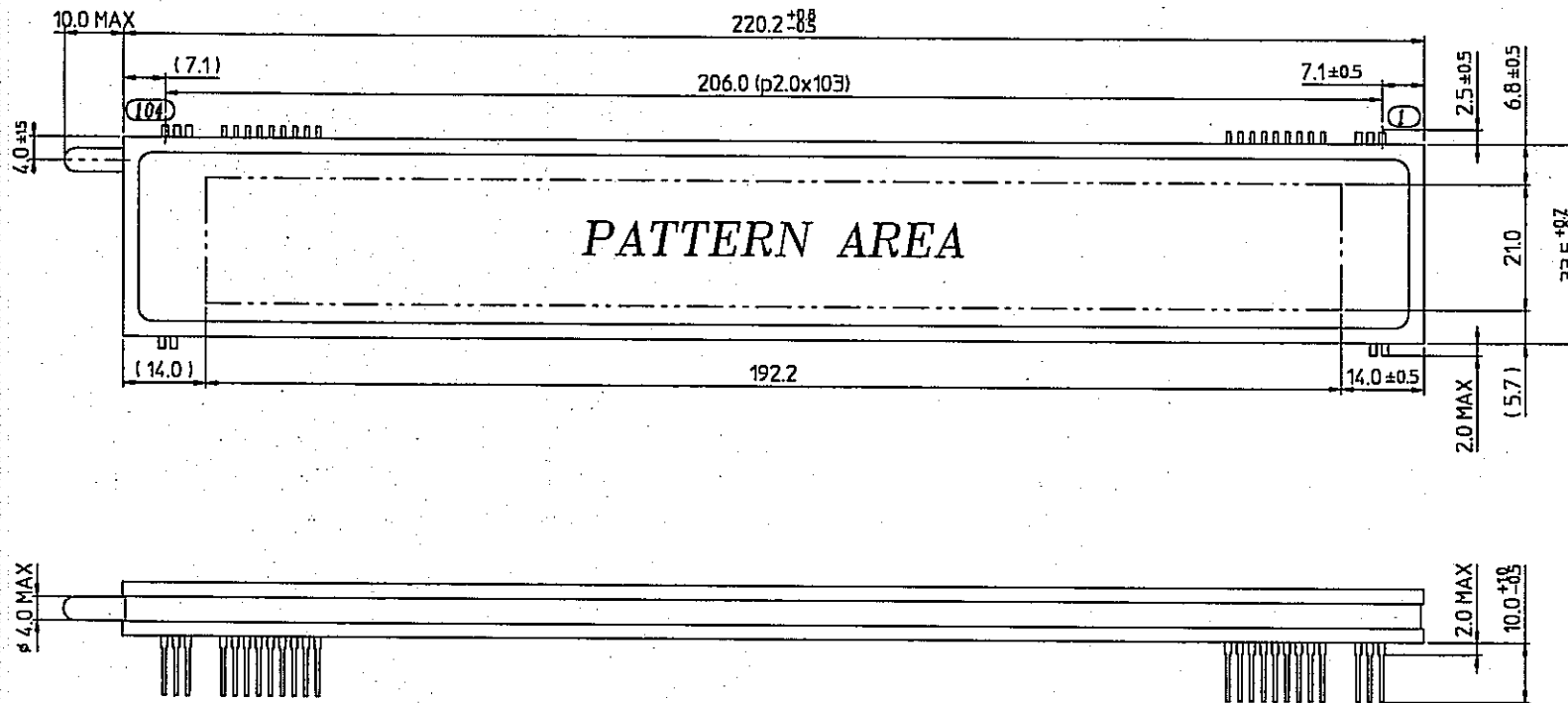

PIN CONNECTION

PIN NO.	104	103	102	101	100	99	98	97	96	95	94	93	92	91	90~15	14~6	5	4	3	2	1
CONNECTION	F2	F2	F2	NP	NP	V _{DEF}	I-GND	D-GND	V _{DD}	OSCO/RST	/CS	/CP	DA	NP	NC	NP	NP	F1	F1	F1	F1

***Notes**

- Fn : Filament Pin
- NP : No Pin
- NC : No Connection Pin

MODEL : HCA-18ML03
 OUTER DIMENSIONS
 Rev. ① 20-Jan-2005

BLOCK DIAGRAM

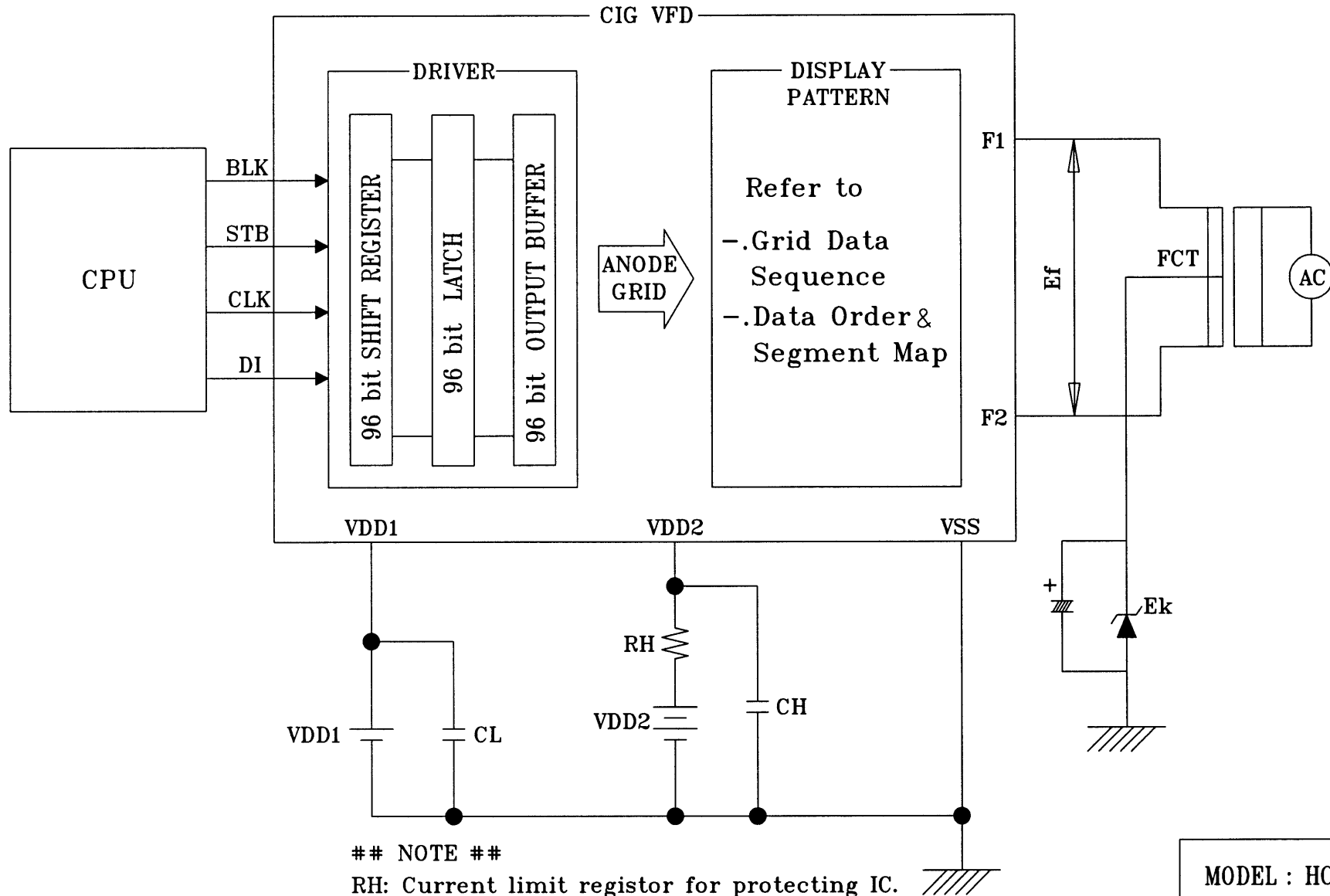

NOTE

RH: Current limit resistor for protecting IC.

CH,CL: Low pass filter for noise filtering.

RH: 22Ω, CH: 0.1 μF, CL: 0.1 μF

FCT: Filament is center-tab grounded.

MODEL : HCA-18ML01
 BLOCK DIAGRAM
 Rev. ① 20-Feb-2003



PATTERN DETAILS

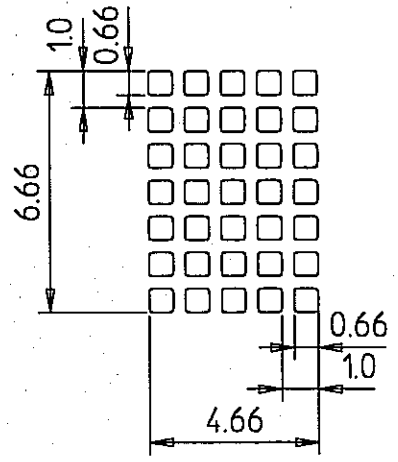
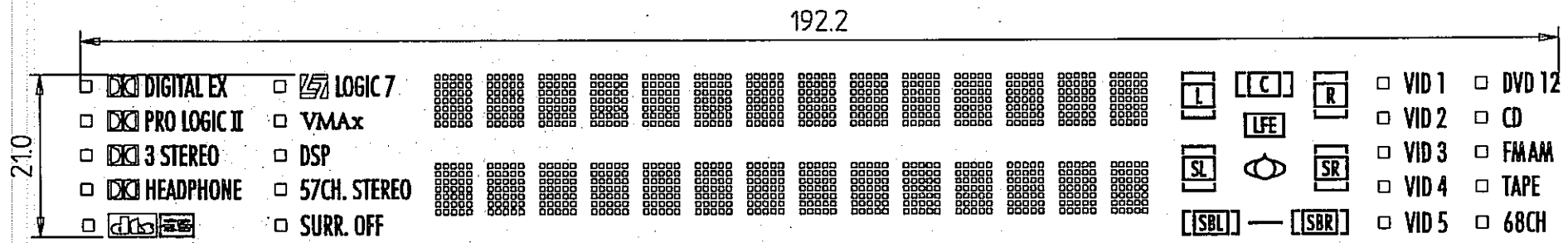

© Color of Illumination ©

• Green (G. $x=0.250, y=0.439$) --- All patterns.

© Negative Patterns ---

MODEL : HCA-18ML03
 PATTERN DETAILS
 Rev. (1) 20-Jan-2005



GRID ASSIGNMENT

<p>1G</p> <input type="checkbox"/> DIGITAL EX <input type="checkbox"/> PRO LOGIC II <input type="checkbox"/> 3 STEREO <input type="checkbox"/> HEADPHONE <input type="checkbox"/>	<p>2G</p> <input type="checkbox"/> LOGIC 7 <input type="checkbox"/> VMAx <input type="checkbox"/> DSP <input type="checkbox"/> 57CH. STEREO <input type="checkbox"/> SURR. OFF	<p>3G</p> <p>○○○○○ ○○○○○ ○○○○○ ○○○○○ ○○○○○</p> <p>○○○○○ ○○○○○ ○○○○○ ○○○○○ ○○○○○</p>	<p>4G</p> <p>○○○○○ ○○○○○ ○○○○○ ○○○○○ ○○○○○</p> <p>○○○○○ ○○○○○ ○○○○○ ○○○○○ ○○○○○</p>	<p>5G</p> <p>○○○○○ ○○○○○ ○○○○○ ○○○○○ ○○○○○</p> <p>○○○○○ ○○○○○ ○○○○○ ○○○○○ ○○○○○</p>	<p>6G</p> <p>○○○○○ ○○○○○ ○○○○○ ○○○○○ ○○○○○</p> <p>○○○○○ ○○○○○ ○○○○○ ○○○○○ ○○○○○</p>	<p>7G</p> <p>○○○○○ ○○○○○ ○○○○○ ○○○○○ ○○○○○</p> <p>○○○○○ ○○○○○ ○○○○○ ○○○○○ ○○○○○</p>	<p>8G</p> <p>○○○○○ ○○○○○ ○○○○○ ○○○○○ ○○○○○</p> <p>○○○○○ ○○○○○ ○○○○○ ○○○○○ ○○○○○</p>	<p>9G</p> <p>○○○○○ ○○○○○ ○○○○○ ○○○○○ ○○○○○</p> <p>○○○○○ ○○○○○ ○○○○○ ○○○○○ ○○○○○</p>	<p>10G</p> <p>○○○○○ ○○○○○ ○○○○○ ○○○○○ ○○○○○</p> <p>○○○○○ ○○○○○ ○○○○○ ○○○○○ ○○○○○</p>	<p>11G</p> <p>○○○○○ ○○○○○ ○○○○○ ○○○○○ ○○○○○</p> <p>○○○○○ ○○○○○ ○○○○○ ○○○○○ ○○○○○</p>	<p>12G</p> <p>○○○○○ ○○○○○ ○○○○○ ○○○○○ ○○○○○</p> <p>○○○○○ ○○○○○ ○○○○○ ○○○○○ ○○○○○</p>	<p>13G</p> <p>○○○○○ ○○○○○ ○○○○○ ○○○○○ ○○○○○</p> <p>○○○○○ ○○○○○ ○○○○○ ○○○○○ ○○○○○</p>	<p>14G</p> <p>○○○○○ ○○○○○ ○○○○○ ○○○○○ ○○○○○</p> <p>○○○○○ ○○○○○ ○○○○○ ○○○○○ ○○○○○</p>	<p>15G</p> <p>○○○○○ ○○○○○ ○○○○○ ○○○○○ ○○○○○</p> <p>○○○○○ ○○○○○ ○○○○○ ○○○○○ ○○○○○</p>	<p>16G</p> <p>○○○○○ ○○○○○ ○○○○○ ○○○○○ ○○○○○</p> <p>○○○○○ ○○○○○ ○○○○○ ○○○○○ ○○○○○</p>	<p>17G</p> <p><input type="checkbox"/> L <input type="checkbox"/> C <input type="checkbox"/> R</p> <p><input type="checkbox"/> LFE <input type="checkbox"/> SR</p> <p><input type="checkbox"/> SL <input type="checkbox"/> </p> <p><input type="checkbox"/> [SBL] — <input type="checkbox"/> [SBR]</p>	<p>18G</p> <p><input type="checkbox"/> VID 1 <input type="checkbox"/> DVD 12</p> <p><input type="checkbox"/> VID 2 <input type="checkbox"/> CD</p> <p><input type="checkbox"/> VID 3 <input type="checkbox"/> FMAM</p> <p><input type="checkbox"/> VID 4 <input type="checkbox"/> TAPE</p> <p><input type="checkbox"/> VID 5 <input type="checkbox"/> 68CH</p>
--	---	--	--	--	--	--	--	--	---	---	---	---	---	---	---	---	---

- 1 2 3 4 5
- 6 7 8 9 10
- 11 12 13 14 15
- 16 17 18 19 20
- 21 22 23 24 25
- 26 27 28 29 30
- 31 32 33 34 35
- 36 37 38 39 40
- 41 42 43 44 45
- 46 47 48 49 50
- 51 52 53 54 55
- 56 57 58 59 60
- 61 62 63 64 65
- 66 67 68 69 70

(3G-16G)

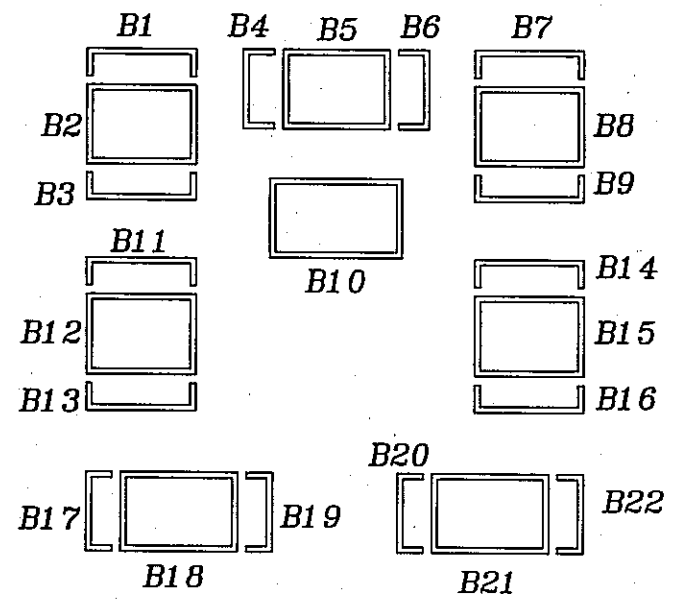

(17G)

MODEL : HCA-18ML03
 GRID ASSIGNMENT
 Rev. ① 20-Jan-2005







ANODE CONNECTION

	COM1	COM2	COM3	~	COM16	COM17	COM18		COM1	COM2	COM3	~	COM16	COM17	COM18
	1G	2G	3G	~	16G	17G	18G		1G	2G	3G	~	16G	17G	18G
SEGB 1	<input type="checkbox"/> (DIGITAL EX)	<input type="checkbox"/> (LOGIC 7)	1	1	1	B1	<input type="checkbox"/> (VID 1)	SEGA 1	<input checked="" type="checkbox"/>	5	36	36	36		
SEGB 2			2	2	2	B2	VID 1	SEGA 2			37	37	37		
SEGB 3			3	3	3	L	<input type="checkbox"/> (DVD 12)	SEGA 3			38	38	38		
SEGB 4			4	4	4	B3	DVD	SEGA 4			39	39	39		
SEGB 5			5	5	5	B4	1	SEGA 5			40	40	40		
SEGB 6	<input checked="" type="checkbox"/> DIGITAL	<input checked="" type="checkbox"/> LOGIC 7	6	6	6	B5	2	SEGA 6	3	7	41	41	41		
SEGB 7			7	7	7	C	<input type="checkbox"/> (VID 2)	SEGA 7			42	42	42		
SEGB 8			8	8	8	B6	VID 2	SEGA 8			43	43	43		
SEGB 9			9	9	9	B7	<input type="checkbox"/> (CD)	SEGA 9			44	44	44		
SEGB 10			10	10	10	B8	CD	SEGA 10			45	45	45		
SEGB 11	EX	<input type="checkbox"/> (VMax)	11	11	11	R	<input type="checkbox"/> (VID 3)	SEGA 11	STEREO	CH. STEREO	46	46	46		
SEGB 12			12	12	12	B9	VID 3	SEGA 12			47	47	47		
SEGB 13			13	13	13	B10	<input type="checkbox"/> (FM AM)	SEGA 13			48	48	48		
SEGB 14			14	14	14	LFE	FM	SEGA 14			49	49	49		
SEGB 15			15	15	15	B11	AM	SEGA 15			50	50	50		
SEGB 16	<input type="checkbox"/> (PRO LOGIC)	VMax	16	16	16	B12	<input type="checkbox"/> (VID 4)	SEGA 16	<input type="checkbox"/> (HEADPHONE)	<input type="checkbox"/> (SURR.OFF)	51	51	51		
SEGB 17			17	17	17	SL	VID 4	SEGA 17			52	52	52		
SEGB 18			18	18	18	B13	<input type="checkbox"/> (TAPE)	SEGA 18			53	53	53		
SEGB 19			19	19	19	⊙	TAPE	SEGA 19			54	54	54		
SEGB 20			20	20	20	B14	<input type="checkbox"/> (VID 5)	SEGA 20			55	55	55		
SEGB 21	<input checked="" type="checkbox"/> PRO LOGIC	<input type="checkbox"/> (DSP)	21	21	21	B15	VID 5	SEGA 21	<input checked="" type="checkbox"/> HEADPHONE	SURR. OFF	56	56	56		
SEGB 22			22	22	22	SR	<input type="checkbox"/> (88CH)	SEGA 22			57	57	57		
SEGB 23			23	23	23	B16	6	SEGA 23			58	58	58		
SEGB 24			24	24	24	B17	8	SEGA 24			59	59	59		
SEGB 25			25	25	25	B18	CH	SEGA 25			60	60	60		
SEGB 26	I	DSP	26	26	26	SBL		SEGA 26	<input type="checkbox"/> (DTS,ES)		61	61	61		
SEGB 27			27	27	27	B19		SEGA 27			62	62	62		
SEGB 28			28	28	28	—		SEGA 28			63	63	63		
SEGB 29			29	29	29	B20		SEGA 29			64	64	64		
SEGB 30			30	30	30	B21		SEGA 30			65	65	65		
SEGB 31	<input type="checkbox"/> (3 STEREO)	<input type="checkbox"/> (57CH.)	31	31	31	SBR		SEGA 31	<input checked="" type="checkbox"/>		66	66	66		
SEGB 32			32	32	32	B22		SEGA 32			67	67	67		
SEGB 33			33	33	33			SEGA 33			68	68	68		
SEGB 34			34	34	34			SEGA 34			69	69	69		
SEGB 35			35	35	35			SEGA 35	<input checked="" type="checkbox"/>		70	70	70		

MODEL : HCA-18LM03
 ANODE CONNECTION
 Rev. ① 20-Jan-2005

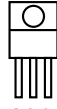
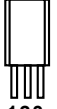
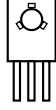
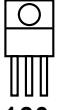
TRANSISTOR, REGULATOR IC BLOCK DIAGRAM

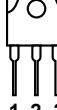
<p>TO-92M</p>  <p>1. Emitter 2. Collector 3. Base</p> <p>123</p> <p>KTC2874B KSC2785Y KRA107M KRC107M KRA104MT KRC104M KTA1267</p>	<p>TO-92</p>  <p>1. Emitter 2. Collector 3. Base</p> <p>123</p> <p>KTD1302T KTA1268GR KTC3200GR KTC3198Y KTA1271Y KSA1175YT</p>	<p>TO-220</p>  <p>1. GND 2. INPUT 3. OUTPUT</p> <p>123</p> <p>MCNJM7905 MC7915C L7905 L7915</p>	<p>TO-92L</p>  <p>1. Emitter 2. Collector 3. Base</p> <p>123</p> <p>KTA1024Y KSC2316Y</p>
<p>TO-126</p>  <p>1. Emitter 2. Collector 3. Base</p> <p>123</p> <p>2SA1360O 2SC3423O KTD600KG</p>	<p>TO-92</p>  <p>1. Emitter 2. Base 3. Collector</p> <p>123</p> <p>KSA733CYT</p>	<p>TO-220</p>  <p>1. INPUT 2. GND 3. OUTPUT</p> <p>123</p> <p>MC7815C MC7805C MC7809 L7805 NJM7824 L7815</p>	<p>TO-3P</p>  <p>1. Base 2. Collector 3. Emitter</p> <p>1 2 3</p> <p>2SB1560 2SD2390 2SA1360 2SB1647 2SD2560</p>

**NJM2391DL1-25 NJM2391DL1-33
LOW DROPOUT VOLTAGE REGULATOR**

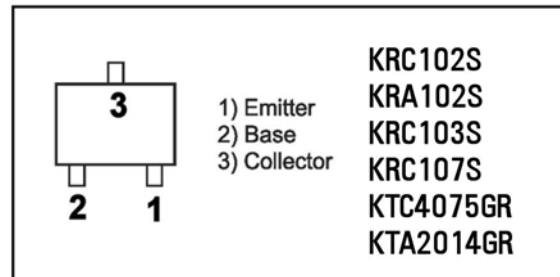
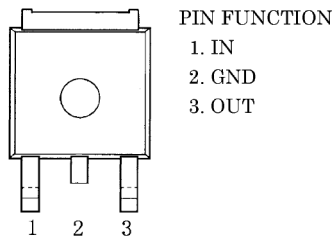

**N-CHANNEL MOS FET ARRAY
μPA672T**

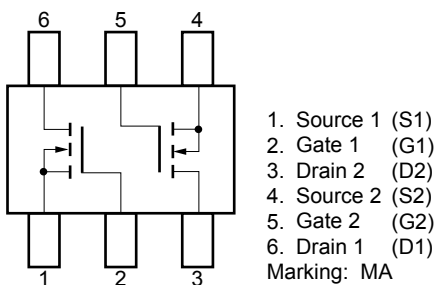

**PIN CONFIGURATION
SOT-23 Package
AD1580**

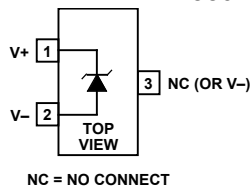

SOT-223 PKG (FRONT VIEW)

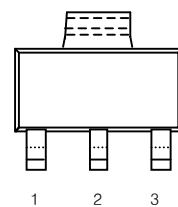

**LM1117
REGULATOR**

- PIN FUNCTION**
1. Adj/Gnd
 2. Vout
 3. Vin

TO-263 (D2 PKG, FRONT VIEW)

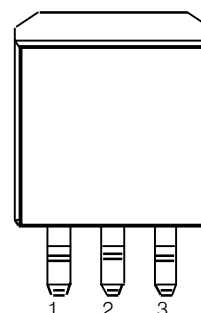

- PIN FUNCTION**
1. Adj/Gnd
 2. Vout
 3. Vin

KP1010 photocoupler

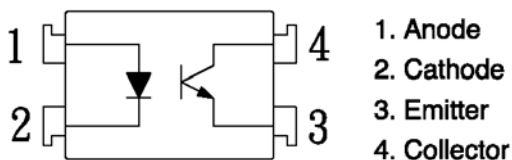

ULTRA-SMALL PACKAGE HIGH-PRECISION VOLTAGE DETECTOR

S-808xxC Series

Rev.3.2_00

■ Pin Configurations

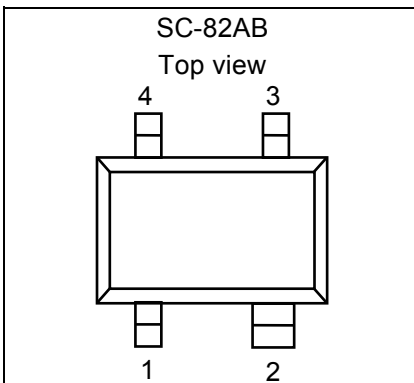

Figure 4

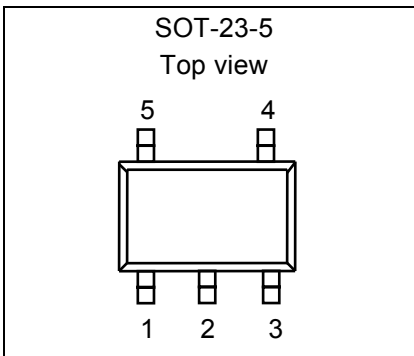

Figure 5

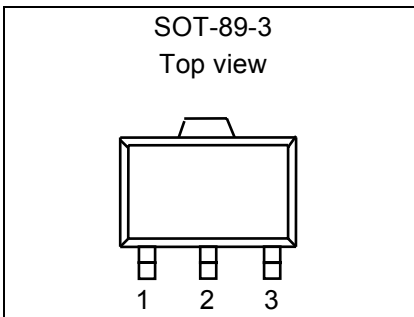

Figure 6

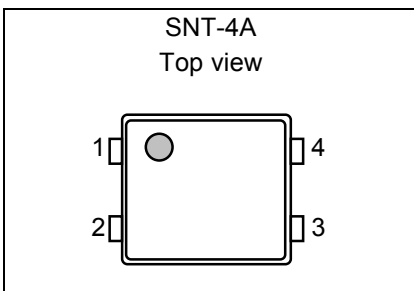

Figure 7

Table 7

Pin No.	Pin name	Pin description
1	OUT	Voltage detection output pin
2	VDD	Voltage input pin
3	NC ^{*1}	No connection
4	VSS	GND pin

*1. The NC pin is electrically open.

The NC pin can be connected to VDD or VSS.

Table 8

Pin No.	Pin name	Pin description
1	OUT	Voltage detection output pin
2	VDD	Voltage input pin
3	VSS	GND pin
4	NC ^{*1}	No connection
5	NC ^{*1}	No connection

*1. The NC pin is electrically open.

The NC pin can be connected to VDD or VSS.

Table 9

Pin No.	Pin name	Pin description
1	OUT	Voltage detection output pin
2	VDD	Voltage input pin
3	VSS	GND pin

Table10

Pin No.	Pin name	Pin description
1	OUT	Voltage detection output pin
2	VSS	GND pin
3	NC ^{*1}	No connection
4	VDD	Voltage input pin

*1. The NC pin is electrically open.

The NC pin can be connected to VDD or VSS.

ULTRA-SMALL PACKAGE HIGH-PRECISION VOLTAGE DETECTOR

S-808xxC Series

Rev.3.2_00

S-80842CNY

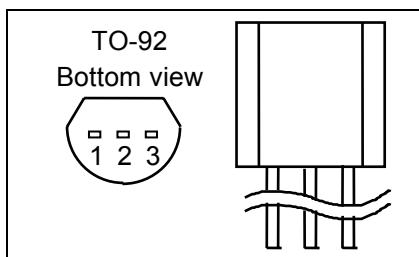

Figure 8

Table 11

Pin No.	Pin name	Pin description
1	OUT	Voltage detection output pin
2	VDD	Voltage input pin
3	VSS	GND pin

■ Absolute Maximum Ratings

1. Detection Voltage Typ. 1.4 V or Less Products

Table 12

(Ta=25°C unless otherwise specified)

Item	Symbol	Absolute maximum ratings	Unit	
Power supply voltage	$V_{DD}-V_{SS}$	7	V	
Output voltage	Nch open-drain output products	$V_{SS}-0.3$ to $V_{SS}+7$	V	
	CMOS output products	$V_{SS}-0.3$ to $V_{DD}+0.3$		
Output current	I_{OUT}	50	mA	
Power dissipation	P_D	SC-82AB	150	mW
		SNT-4A	140	
Operating ambient temperature	T_{opr}	-40 to +85	°C	
Storage temperature	T_{stg}	-40 to +125		

Caution The absolute maximum ratings are rated values exceeding which the product could suffer physical damage. These values must therefore not be exceeded under any conditions.

2. Detection Voltage Typ. 1.5 V or More Products

Table 13

(Ta=25°C unless otherwise specified)

Item	Symbol	Absolute maximum ratings	Unit	
Power supply voltage	$V_{DD}-V_{SS}$	12	V	
Output voltage	Nch open-drain output products	$V_{SS}-0.3$ to $V_{SS}+12$	V	
	CMOS output products	$V_{SS}-0.3$ to $V_{DD}+0.3$		
Output current	I_{OUT}	50	mA	
Power dissipation	P_D	SC-82AB	150	mW
		SOT-23-5	250	
		SOT-89-3	500	
		SNT-4A	140	
		TO-92	400	
Operating ambient temperature	T_{opr}	-40 to +85	°C	
Storage temperature	T_{stg}	-40 to +125		

Caution The absolute maximum ratings are rated values exceeding which the product could suffer physical damage. These values must therefore not be exceeded under any conditions.

RN5RZ

RN5RZ50BA

PIN CONFIGURATION

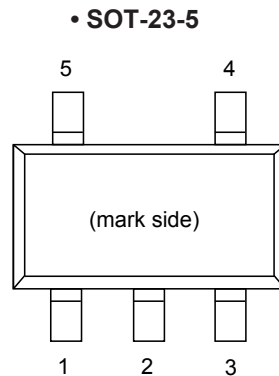

PIN DESCRIPTION

Pin No.	Symbol	Description
1	GND	Ground Pin
2	VDD	Input Pin
3	VOUT	Output Pin
4	NC	No Connection
5	CE or $\overline{\text{CE}}$	Chip Enable Pin

ABSOLUTE MAXIMUM RATINGS

Symbol	Item	Ratings	Unit
V _{IN}	Input Voltage	9	V
V _{CE}	Input Voltage (CE or $\overline{\text{CE}}$ Pin)	-0.3 to V _{IN} +0.3	V
V _{OUT}	Output Voltage	-0.3 to V _{IN} +0.3	V
I _{OUT}	Output Current	200	mA
P _D	Power Dissipation	250	mW
T _{opt}	Operating Temperature	-40 to +85	°C
T _{stg}	Storage Temperature	-55 to +125	°C

CUP11911X

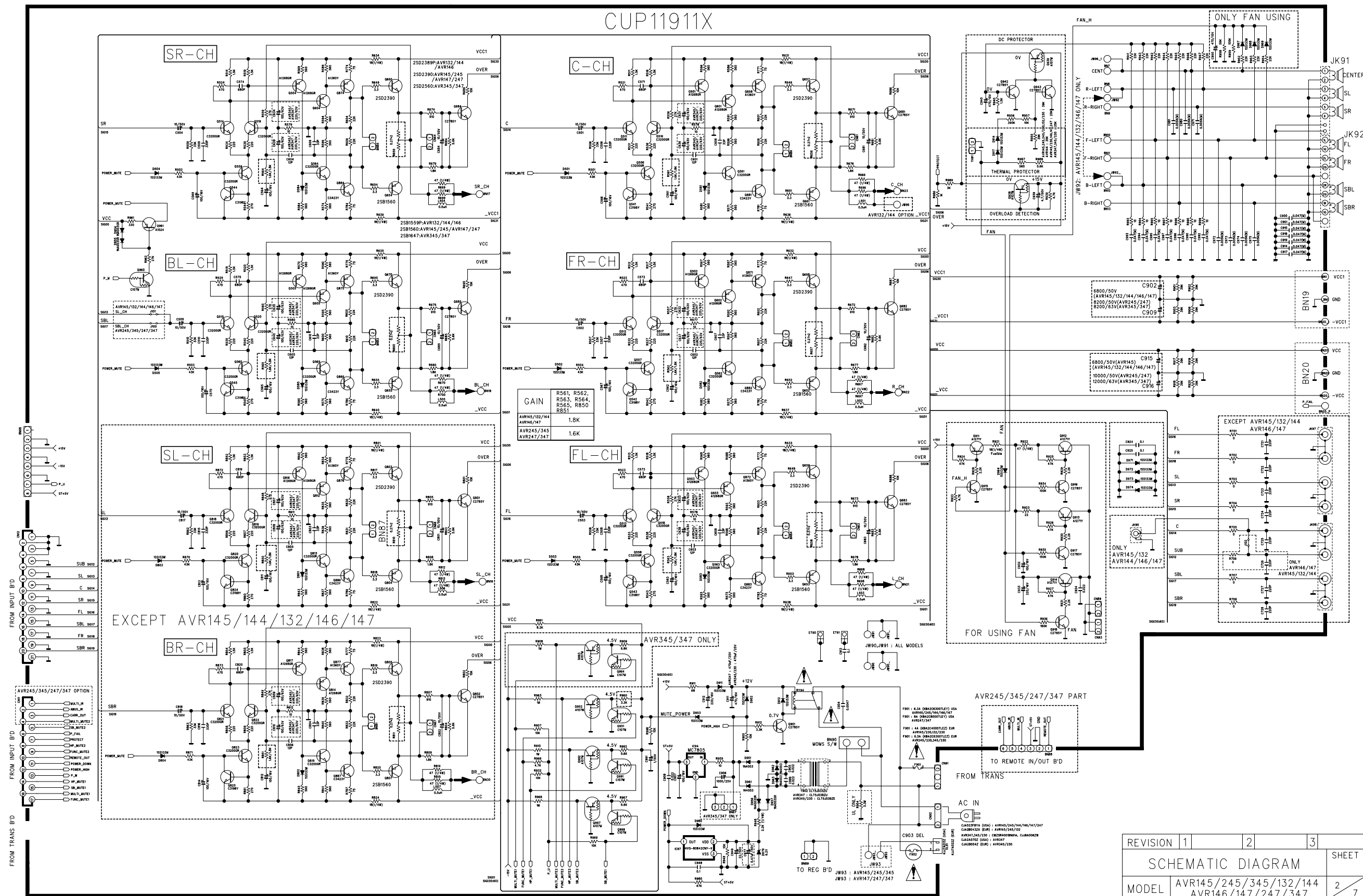

•• IMPORTANT SAFETY NOTICE.
 IMPORTANT FOR SAFETY WHEN REPLACING ANY OF THESE COMPONENTS
 USE ONLY MANUFACTURER'S SPECIFIED PARTS.
 •• THE UNIT OF RESISTANCE IS OHM.
 K=1000 OHM, M=1000 KOHM.
 •• THE UNIT OF CAPACITANCE IS MICROFARAD (uF)
 uF = 10⁻⁶ uF
 •• THIS SCHEMATIC DIAGRAM MAY BE MODIFIED AT ANY TIME WHILE THE
 IMPROVEMENT OF PERFORMANCE

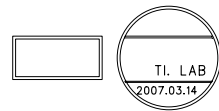

REVISION	1	2	3	SHEET
SCHEMATIC DIAGRAM				2
MODEL	AVR145/245/345/132/144 AVR146/147/247/347			7
DESIGN	CHECK	APPROVE	DRAWING NO	
C.B.L	W.Y.Y	H.W.L	1911SCMX (MAIN)	
07.03.14	07.03.14	07.03.14		

CUP11915Z

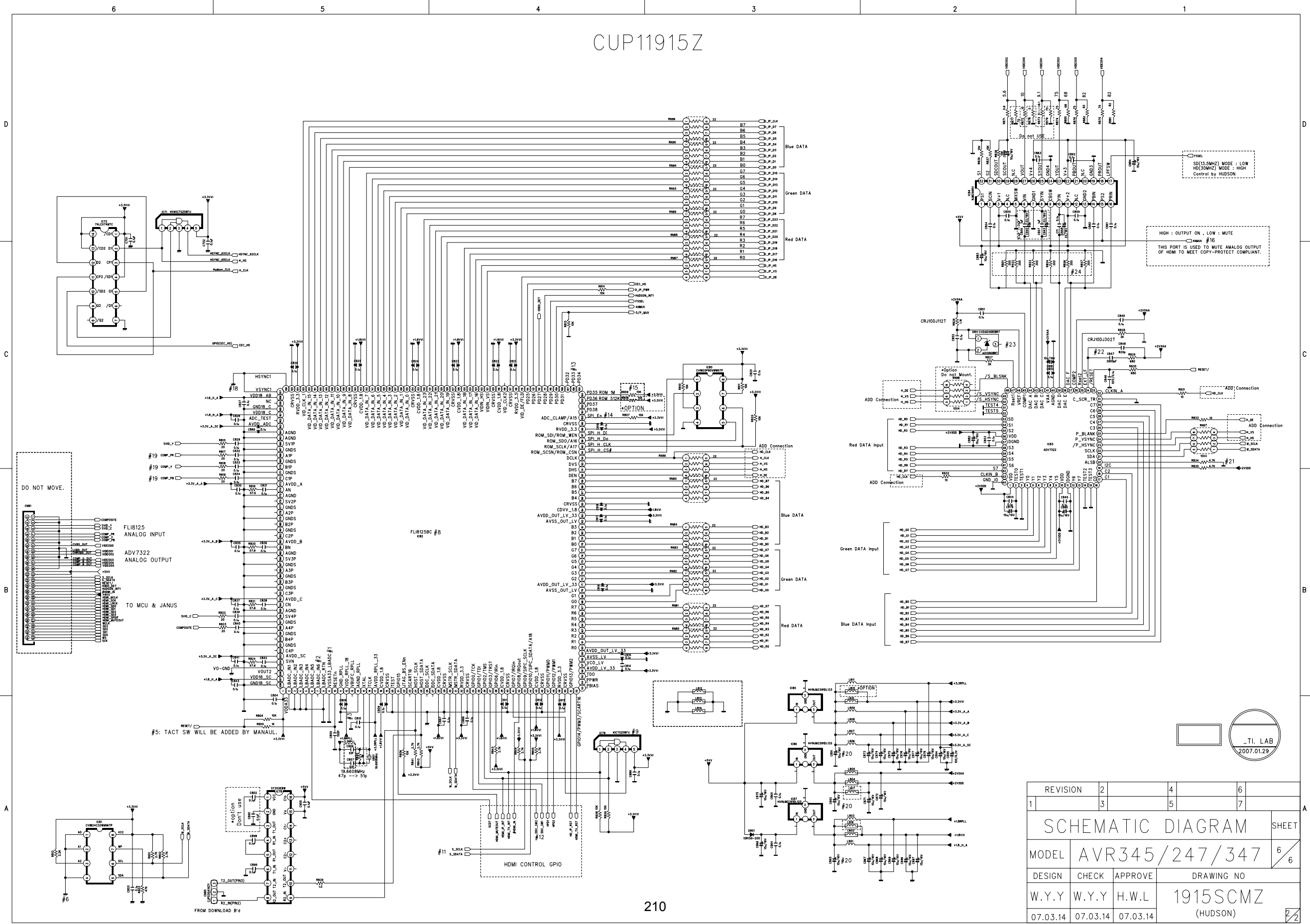

REVISION	2	4	6
1	3	5	7
SCHEMATIC DIAGRAM			
MODEL	AVR345/247/347		
DESIGN	W.Y.Y	W.Y.Y	H.W.L
W.Y.Y	W.Y.Y	H.W.L	1915SCMZ
			(HUDSON)



CUP11913Z

AVR345/247/347 PART (IPOD SECTION)

AVR247/347 OPTION(XM)

AVR345 PART RDS SECTION(EUR Ver. ONLY)

TO VIDEO PCB

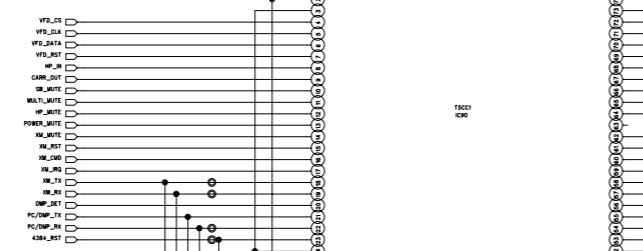
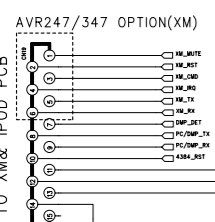
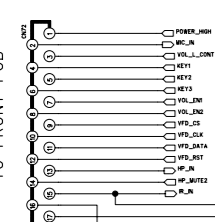
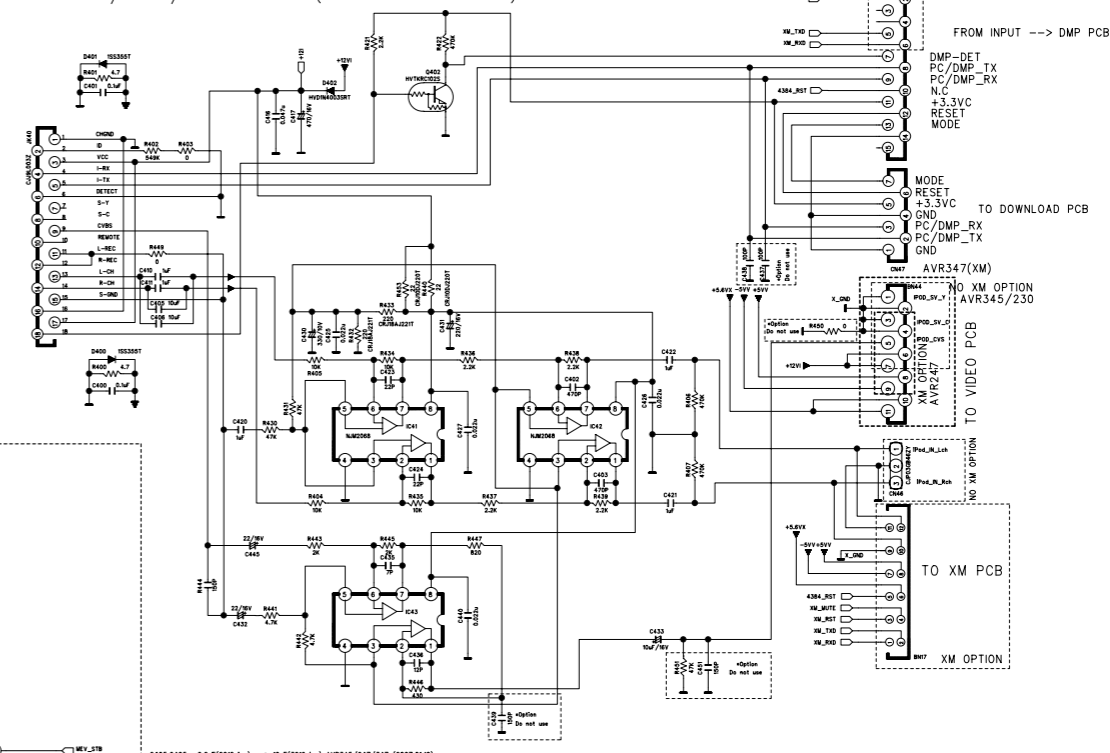
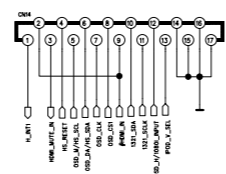
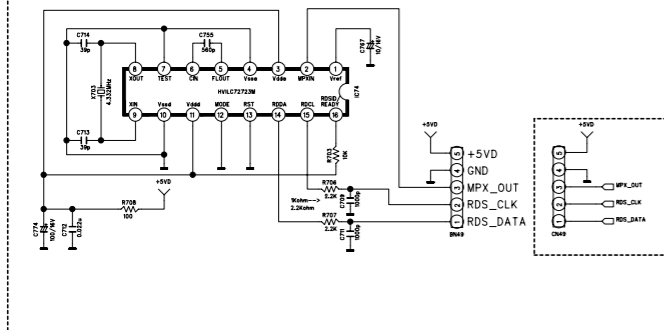

○: PULL_UP
GPIO : Input/Out Port(without pull_up resistor)

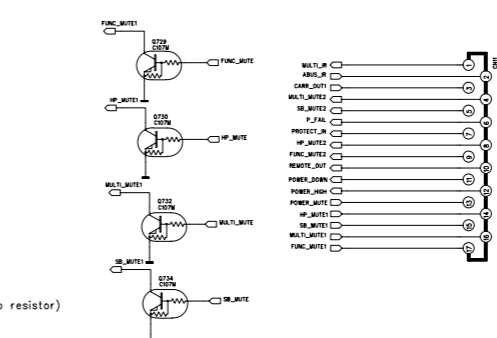

MODEL	OP_A(PIN48)	OP_B(PIN98)	OP_C(PIN52)
AVR145, 147	HIGH(R792)	LOW(R791)	LOW(R712)
AVR245	LOW(R793)	LOW(R791)	LOW(R712)
NONE	OPEN	LOW(R791)	NOT OPTION
AVR132	LOW(R793)	HIGH(R790)	LOW(R712)
AVR144, 146	HIGH(R792)	HIGH(R790)	LOW(R712)
AVR145/230	HIGH(R792)	LOW(R791)	HIGH(R711)
AVR245/230	LOW(R793)	LOW(R791)	HIGH(R711)
AVR347	HIGH(R792)	LOW(R791)	NOT OPTION
AVR247	LOW(R793)	LOW(R791)	NOT OPTION
AVR345/230	HIGH(R792)	HIGH(R790)	NOT OPTION

AVR345/347 PART (CARRIER OUT SECTION)

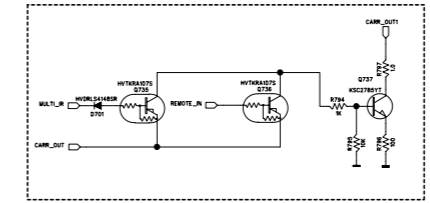

AVR345/247/347 PART

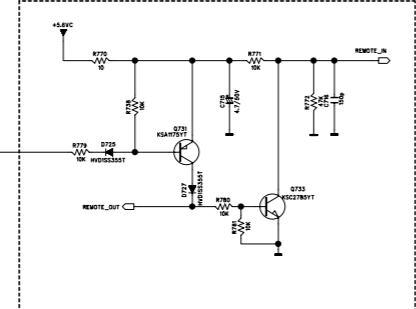

REVISION	2	4	6
	3	5	7
SCHEMATIC DIAGRAM			
MODEL	AVR345/247/347		
DESIGN	CHECK	APPROVE	DRAWING NO
M.S.K	W.Y.Y	H.W.L	1913SCMZ
07.01.18	07.01.18	07.01.18	(CPU)

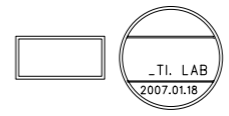

CUP11913Z

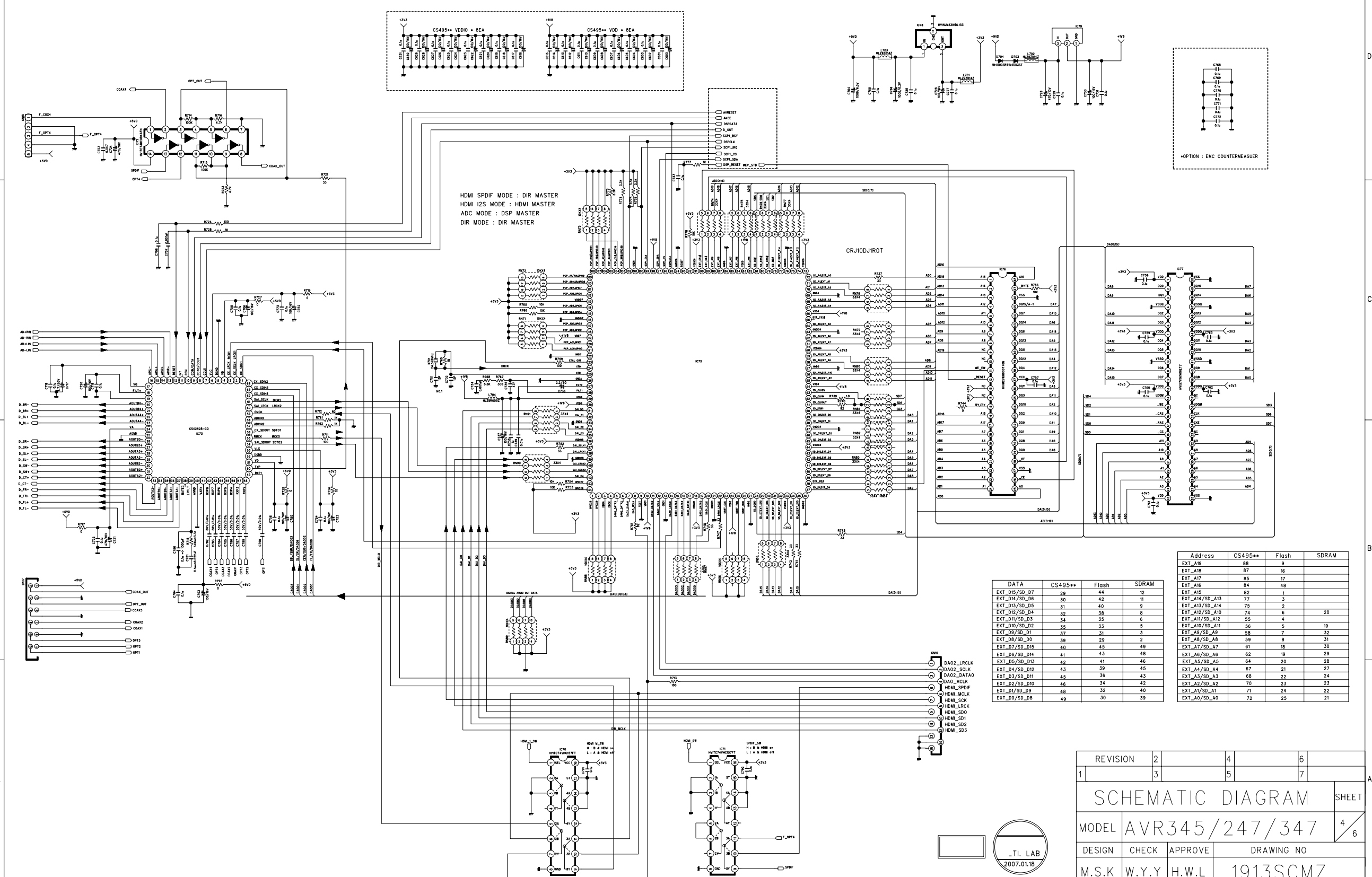

HDMI SPDIF MODE : DIR MASTER
 HDMI I2S MODE : HDMI MASTER
 ADC MODE : DSP MASTER
 DIR MODE : DIR MASTER

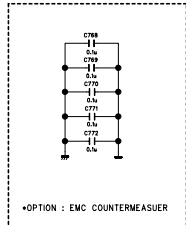

DATA	CS495**	Flash	SDRAM
EXT_D15/SD_D7	29	44	12
EXT_D14/SD_D6	30	42	11
EXT_D13/SD_D5	31	40	9
EXT_D12/SD_D4	32	38	8
EXT_D11/SD_D3	34	35	6
EXT_D10/SD_D2	35	33	5
EXT_D9/SD_D1	37	31	3
EXT_D8/SD_D0	39	29	2
EXT_D7/SD_D15	40	45	49
EXT_D6/SD_D14	41	43	48
EXT_D5/SD_D13	42	41	46
EXT_D4/SD_D12	43	39	45
EXT_D3/SD_D11	45	36	43
EXT_D2/SD_D10	46	34	42
EXT_D1/SD_D9	48	32	40
EXT_D0/SD_D8	49	30	39

Address	CS495**	Flash	SDRAM
EXT_A19	88	9	
EXT_A18	87	16	
EXT_A17	85	17	
EXT_A16	84	48	
EXT_A15	82	1	
EXT_A14/SD_A13	77	3	
EXT_A13/SD_A14	75	2	
EXT_A12/SD_A10	74	6	20
EXT_A11/SD_A12	53	4	
EXT_A10/SD_A11	56	5	19
EXT_A9/SD_A9	58	7	32
EXT_A8/SD_A8	59	8	31
EXT_A7/SD_A7	61	18	30
EXT_A6/SD_A6	62	19	29
EXT_A5/SD_A5	64	20	28
EXT_A4/SD_A4	67	21	27
EXT_A3/SD_A3	68	22	24
EXT_A2/SD_A2	70	23	23
EXT_A1/SD_A1	71	24	22
EXT_A0/SD_A0	72	25	21

REVISION	2	4	6
1	3	5	7
SCHEMATIC DIAGRAM			
MODEL	AVR345/247/347		
DESIGN	CHECK	APPROVE	DRAWING NO
M.S.K	W.Y.Y	H.W.L	1913SCMZ
07.01.18	07.01.18	07.01.18	(DSP)



CUP11913Z

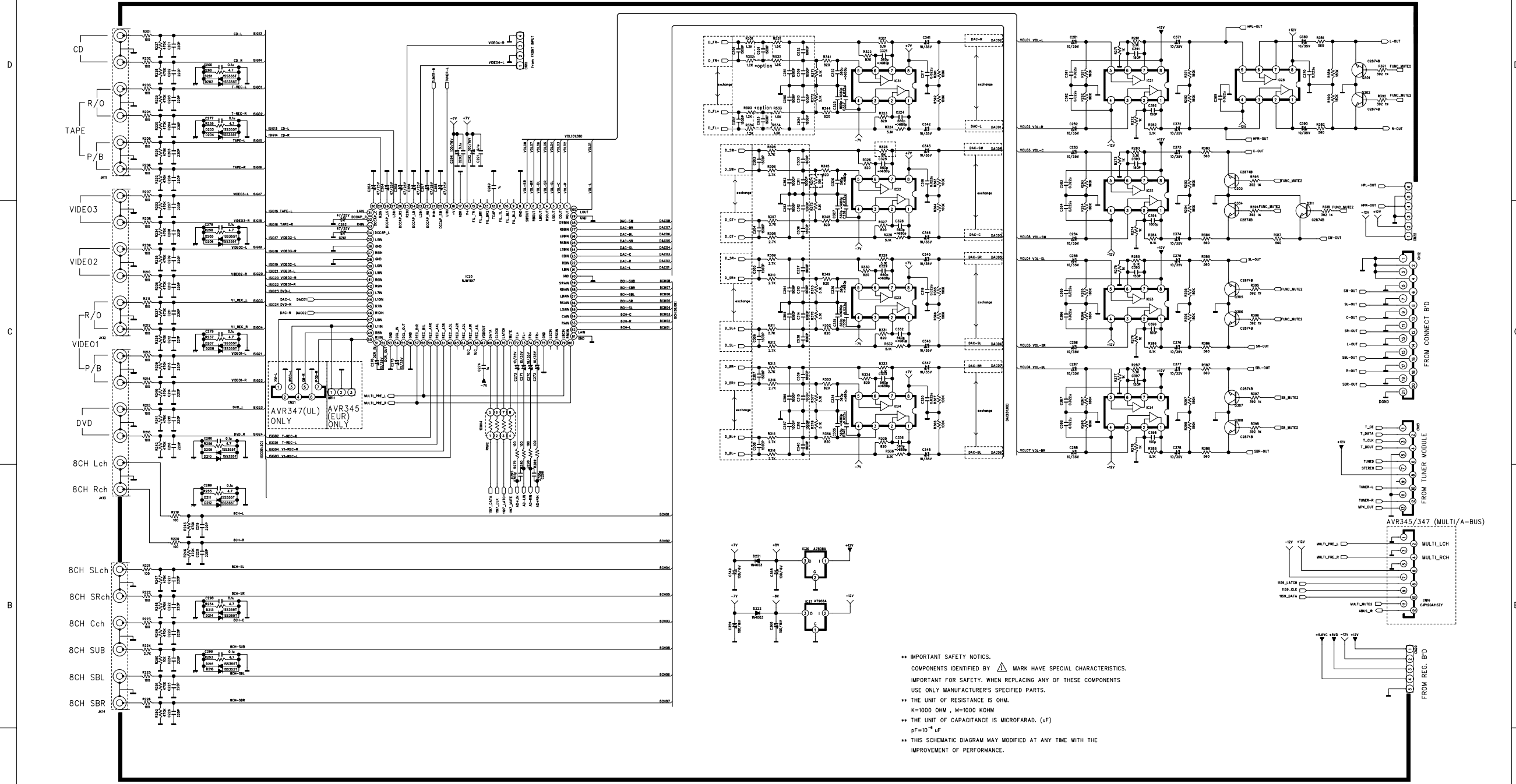

•• IMPORTANT SAFETY NOTICES.
 COMPONENTS IDENTIFIED BY Δ MARK HAVE SPECIAL CHARACTERISTICS.
 IMPORTANT FOR SAFETY, WHEN REPLACING ANY OF THESE COMPONENTS
 USE ONLY MANUFACTURER'S SPECIFIED PARTS.
 •• THE UNIT OF RESISTANCE IS OHM.
 K=1000 OHM , M=1000 KOHM
 •• THE UNIT OF CAPACITANCE IS MICROFARAD. (μ F)
 $pF=10^{-12}$ uF
 •• THIS SCHEMATIC DIAGRAM MAY MODIFIED AT ANY TIME WITH THE
 IMPROVEMENT OF PERFORMANCE.

REVISION	2	4	6
1	3	5	7
SCHEMATIC DIAGRAM			
MODEL	AVR345/247/347		
DESIGN	CHECK	APPROVE	DRAWING NO
M.S.K	W.Y.Y	H.W.L	1913SCMZ
07.01.18	07.01.18	07.01.18	(INPUT)

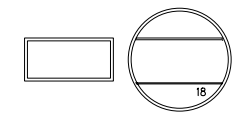

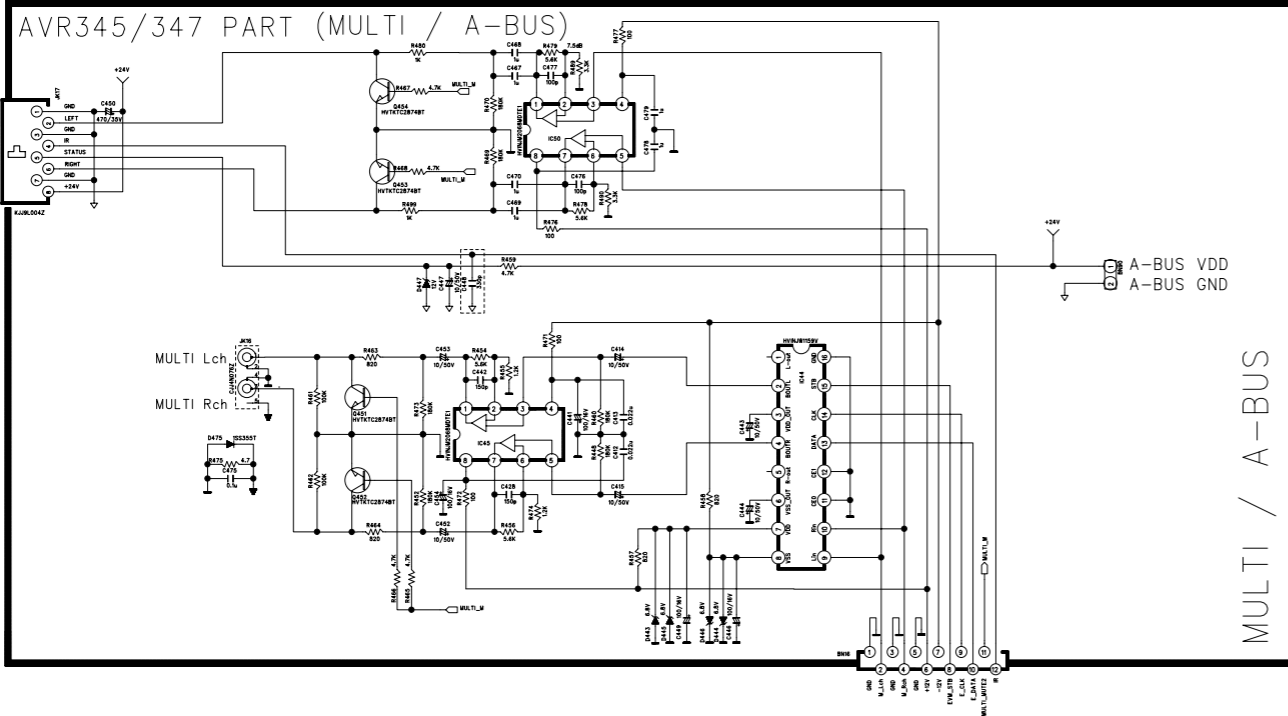

CUP11913Z

AVR345/347 PART (REGULATOR SECTION)

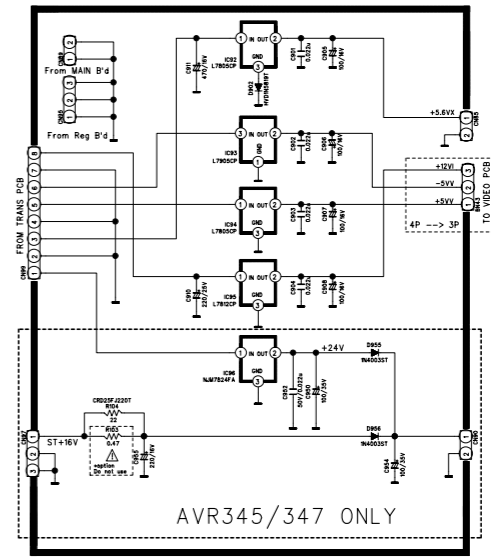

AVR247/347 PART (XM SECTION USA Ver. ONLY)

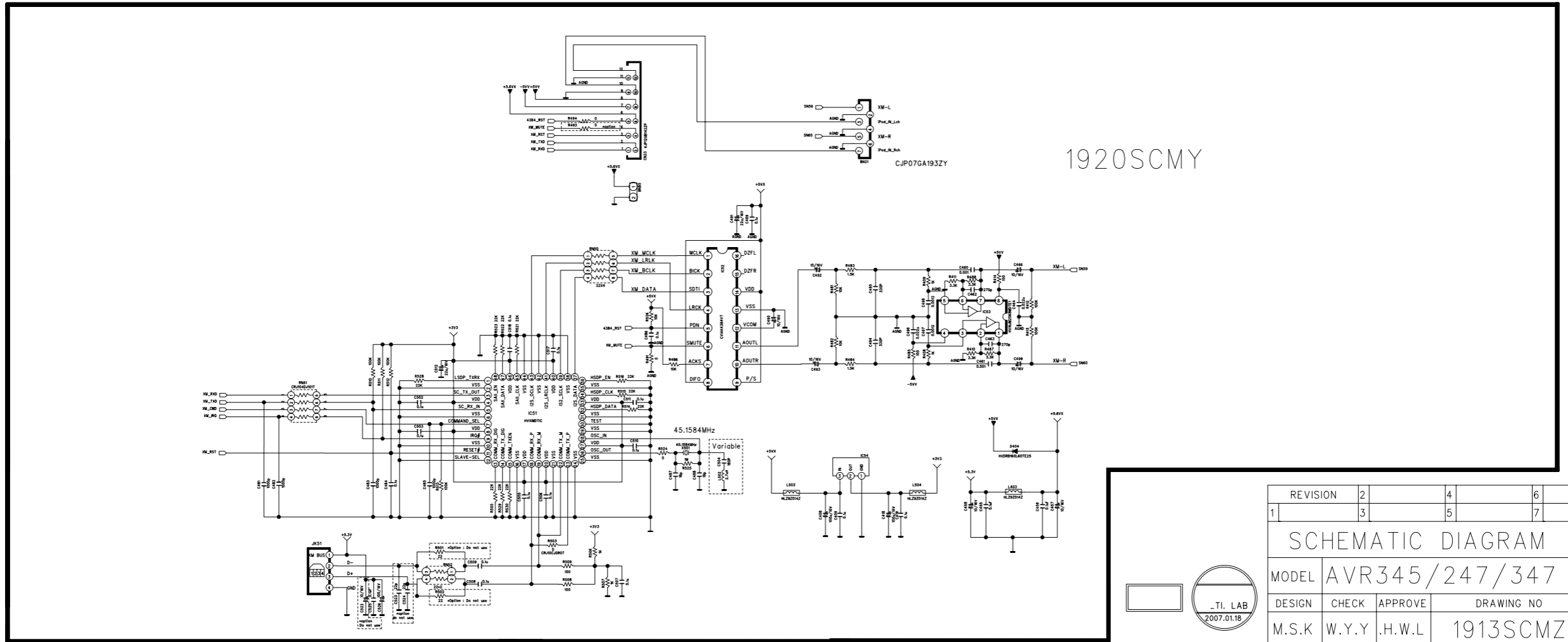

1920SCMY

REVISION	2	4	6
1	3	5	7
SCHEMATIC DIAGRAM			
MODEL	AVR345/247/347		
DESIGN	CHECK	APPROVE	DRAWING NO
M.S.K	W.Y.Y	H.W.L	1913SCMZ
07.01.18	07.01.18	07.01.18	(MULTI)

AVR145/245/345/147/247/347 PART

CUP11910X

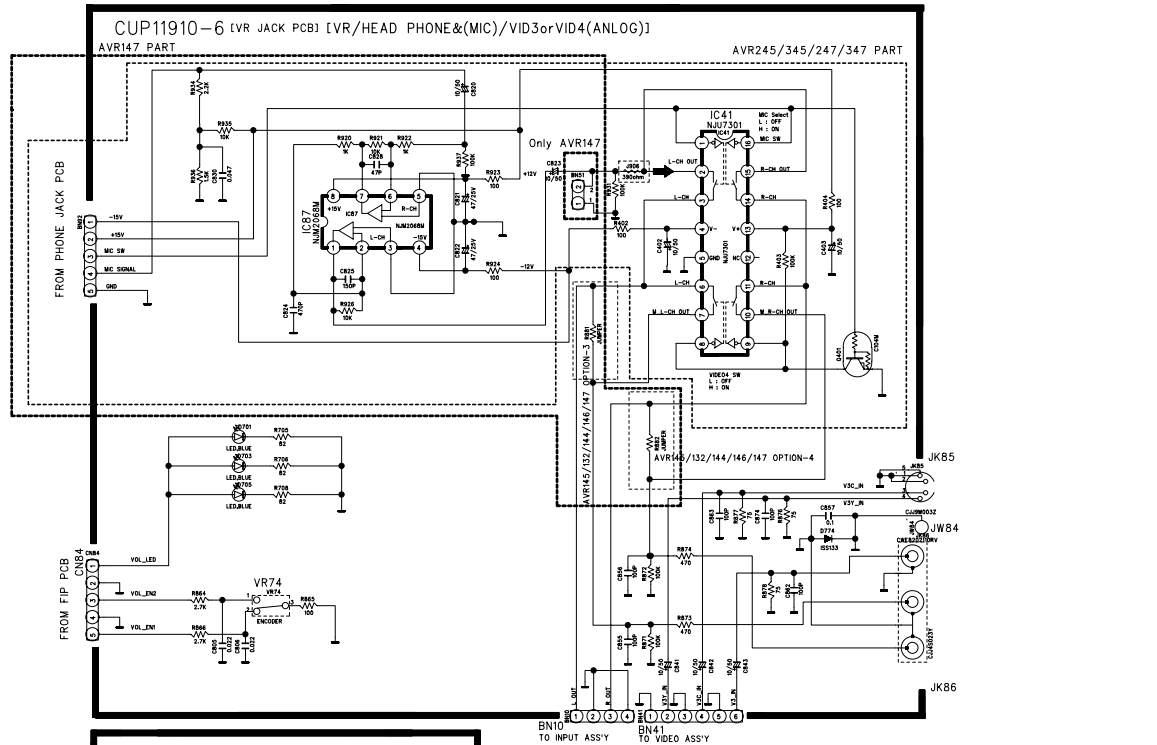
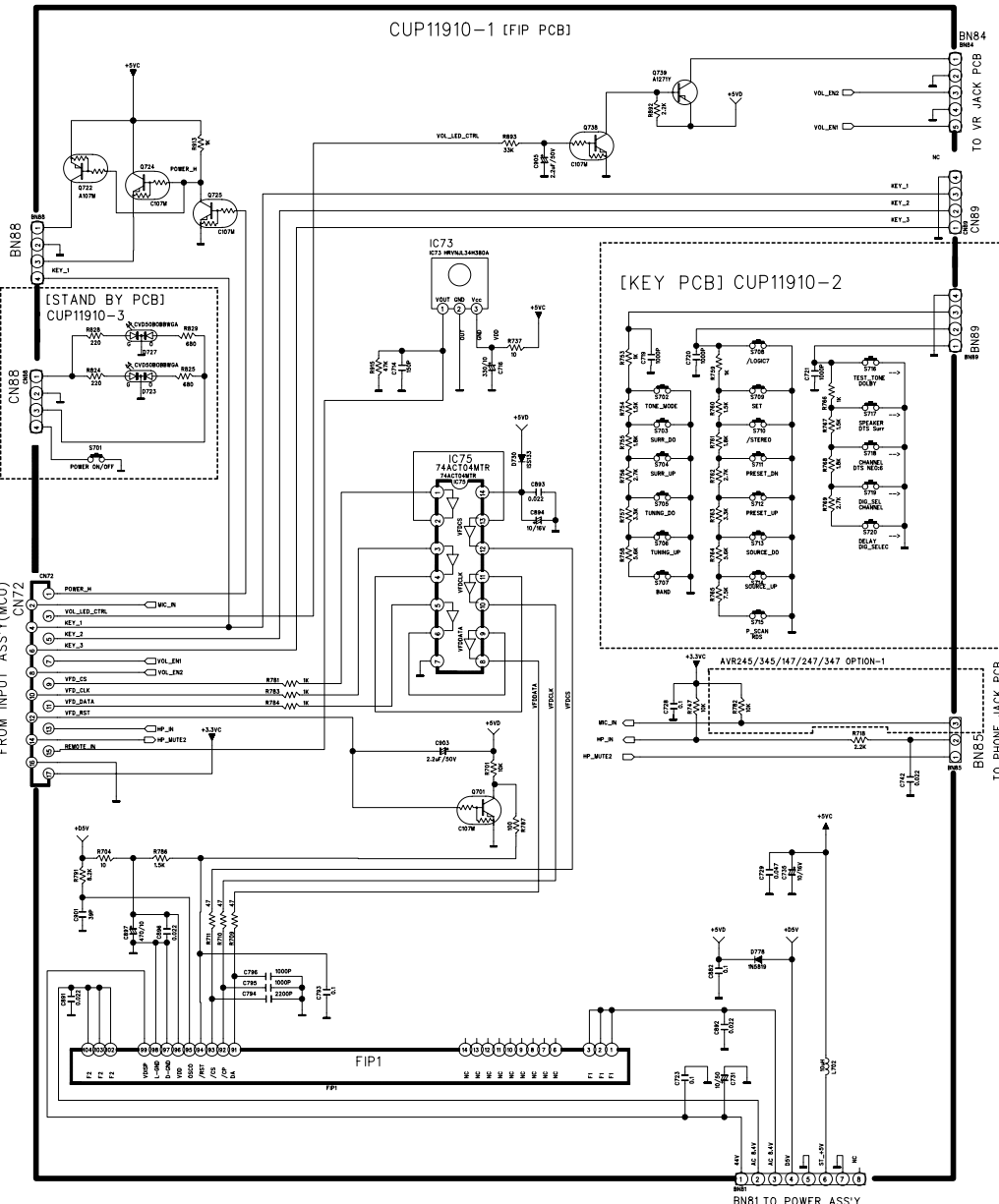
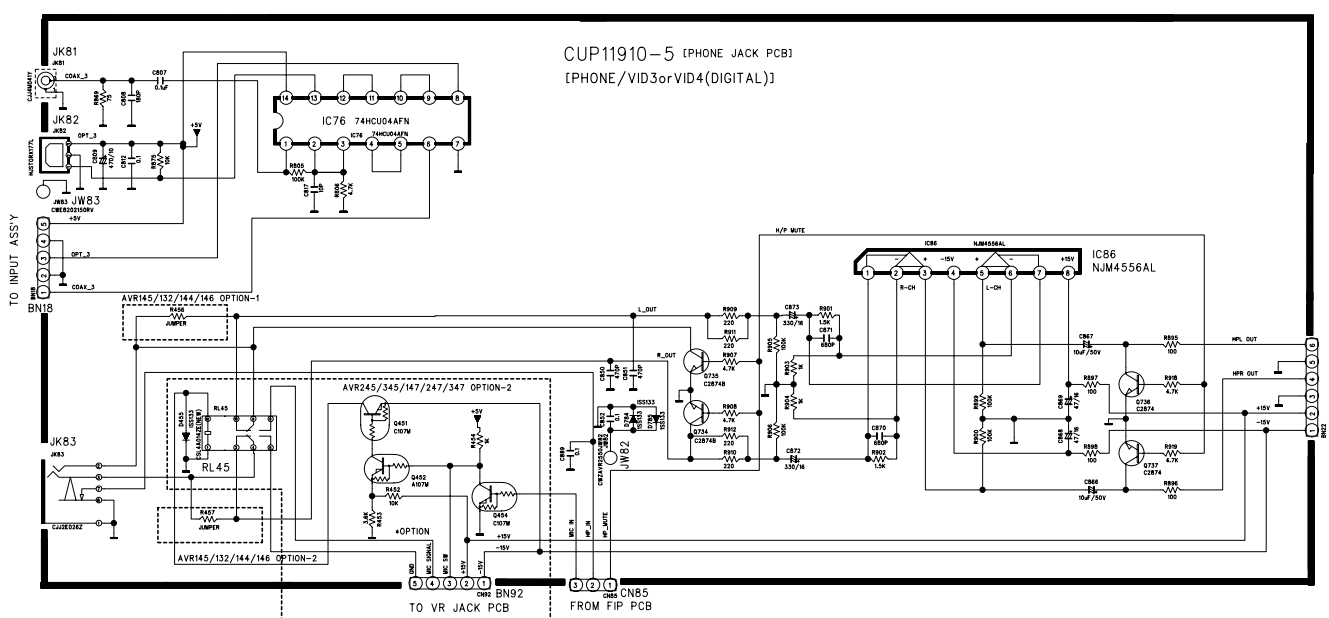
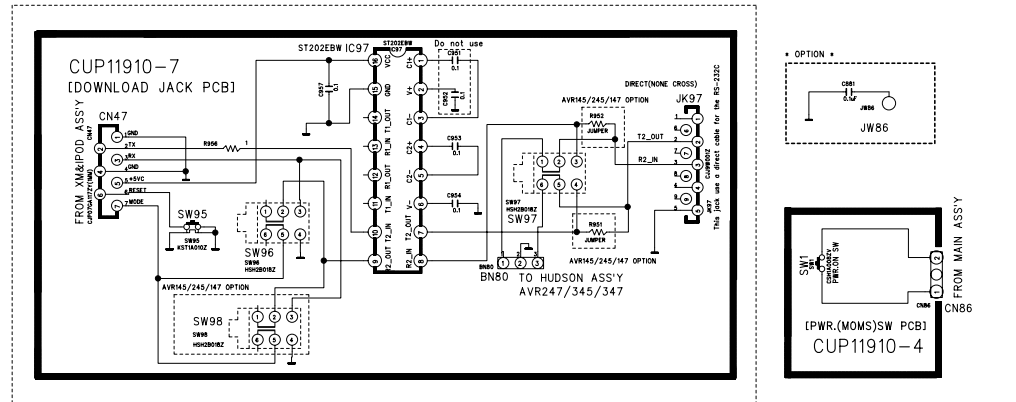

REVISION	2	4	6
1	3	5	7
SCHEMATIC DIAGRAM			
MODEL	AVR145/245/345/132/144 AVR146/147/247/347		
DESIGN	CHECK	APPROVE	DRAWING NO
S.H.Y	W.Y.Y	H.Y.L	1910SCMX
07.01.18	07.01.18	07.01.18	(FRONT)



CUP11918Z

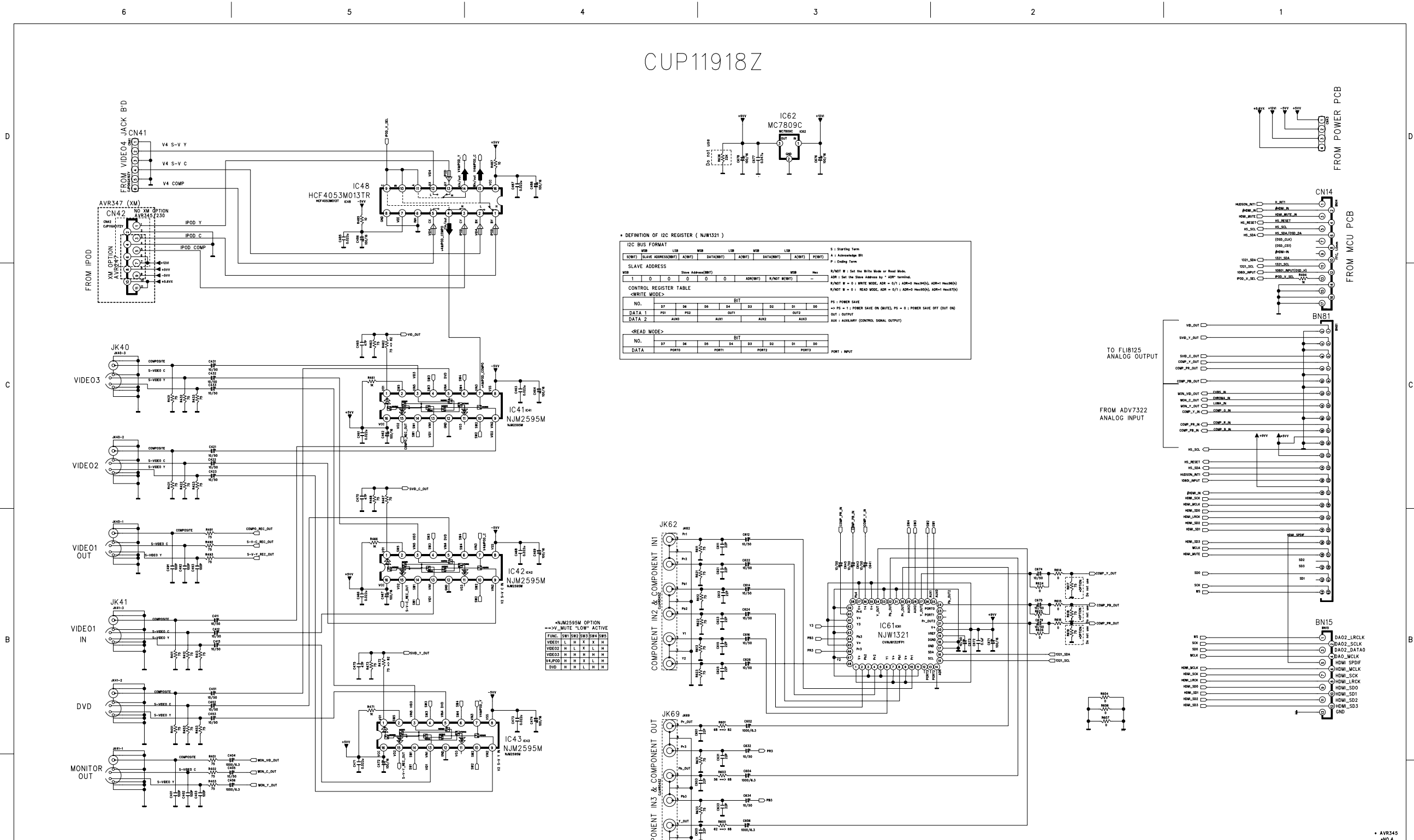

• DEFINITION OF I2C REGISTER (NJW1321)

I2C BUS FORMAT

SBT	SLAVE ADDRESS	DATA	ACK	DATA	ACK	DATA	ACK	DATA	ACK	DATA	ACK	DATA	ACK	DATA	ACK	DATA	ACK	DATA	ACK
1	0	0	0	0	0	0	0	0	0	0	0	0	0	0	0	0	0	0	0

CONTROL REGISTER TABLE

<WRITE MODE>

NO.	D7	D6	D5	D4	D3	D2	D1	D0
DATA 1	PS1	AUX1	AUX2	AUX3	AUX4	AUX5	AUX6	AUX7
DATA 2								

<READ MODE>

NO.	D7	D6	D5	D4	D3	D2	D1	D0
DATA	PORT0	PORT1	PORT2	PORT3	PORT4	PORT5	PORT6	PORT7

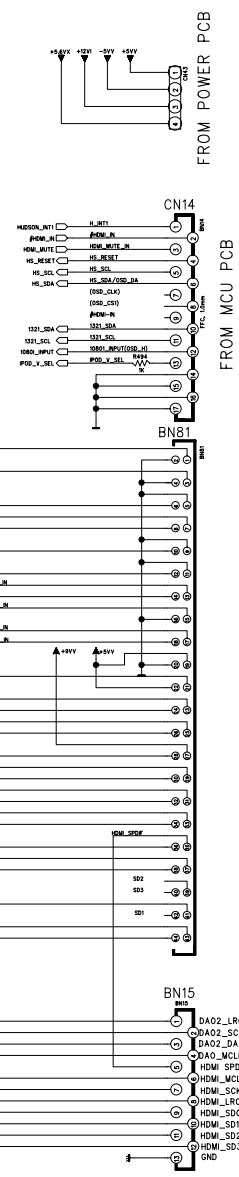
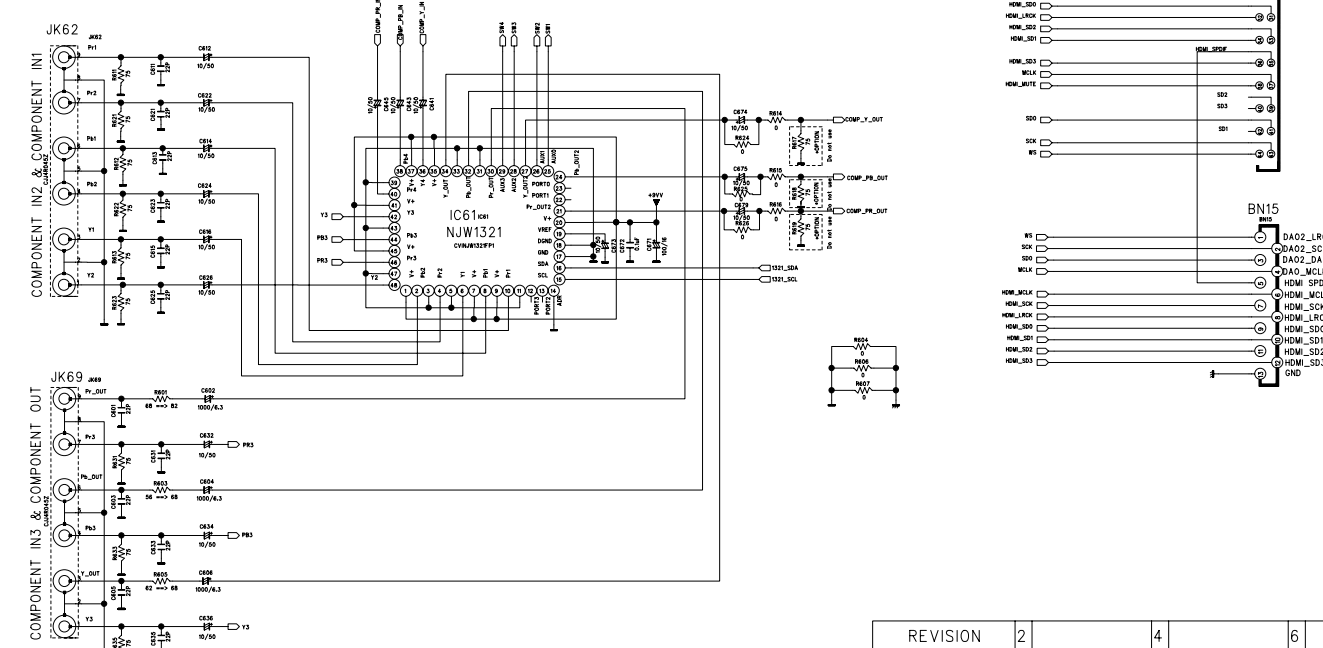

TO FL18125 ANALOG OUTPUT

FROM ADV7322 ANALOG INPUT

• NJM2595M OPTION

• S-V MUTE "LOW" ACTIVE

FUNC.	S1	S2	S3	S4	S5
VIDEO1	L	L	L	L	L
VIDEO2	H	L	L	L	L
VIDEO3	H	L	L	L	L
IPDOD	H	L	L	L	L
DVD	H	L	L	L	L

REVISION	2	4	6
1	3	5	7
SCHEMATIC DIAGRAM			
MODEL	AVR345/247/347		
DESIGN	CHECK	APPROVE	DRAWING NO
C.B.L	W.Y.Y.	H.W.L	1918SCMZ
07.01.29	07.01.29	07.01.29	(VIDEO)

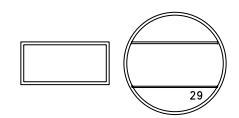

AVR347/345 WIRING DIAGRAM

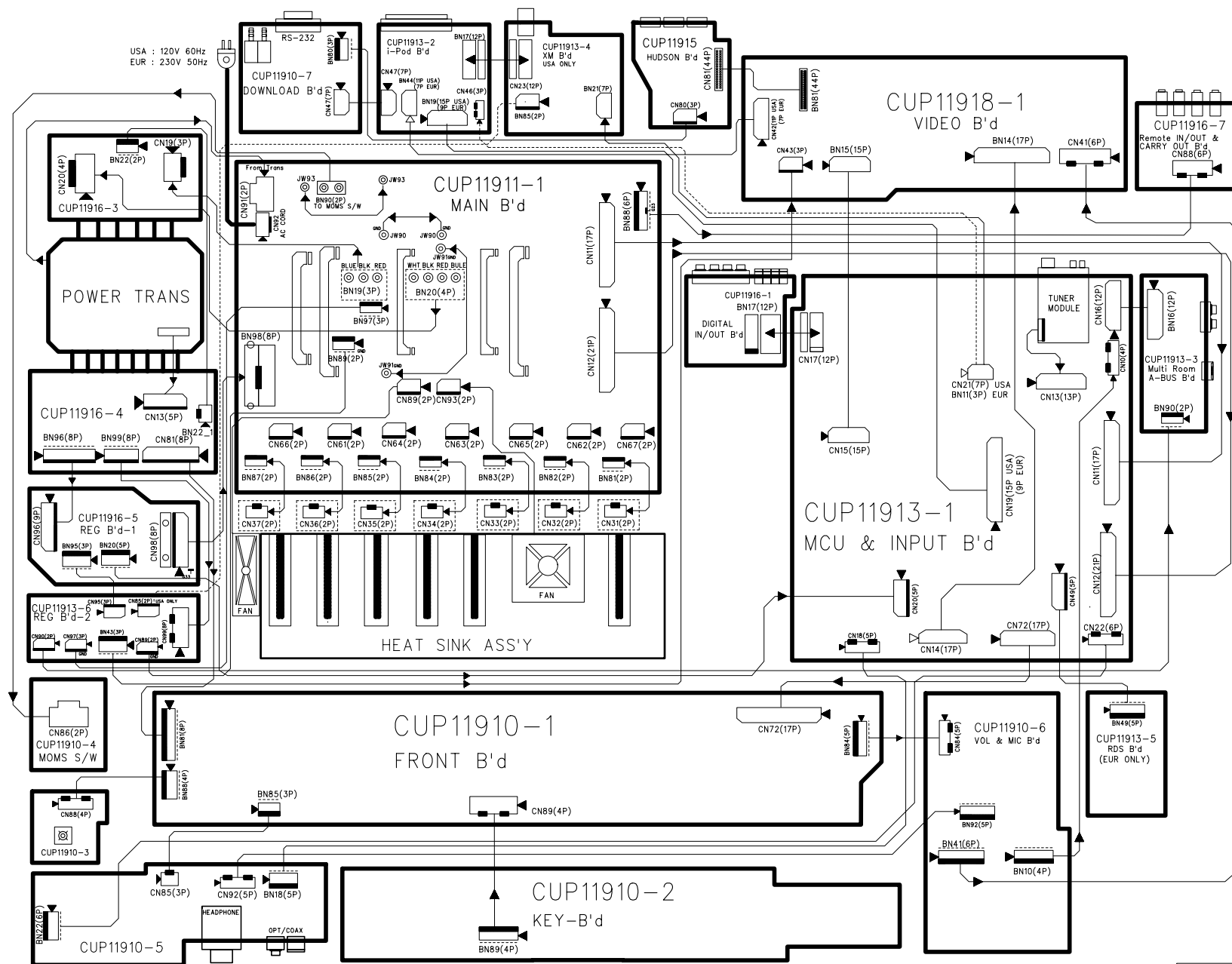

.T1.LAB
2007.03.14

REVISION	2	4	6	
	3	5	7	
SCHEMATIC DIAGRAM				SHEET
MODEL	AVR347/345			1 1
DESIGN	CHECK	APPROVE	DRAWING NO	
J.T:B	W.Y.Y	H.W.L	WIRING DIAGRAM	
07.03.14	07.03.14	07.03.14	1190SCDZ	